

















Workshop Manual



Workshop manual DEFENDER 90 - NAS

This manual covers vehicles from
1997 model year

01	INTRODUCTION
04	GENERAL SPECIFICATION DATA
05	ENGINE TUNING DATA
07	GENERAL FITTING REMINDERS
09	LUBRICANTS, FLUIDS AND CAPACITIES
10	MAINTENANCE
12	ENGINE 4.0 V8
17	EMISSION CONTROL
19	FUEL SYSTEM SFI
26	COOLING SYSTEM
30	MANIFOLD AND EXHAUST SYSTEM
41	TRANSFER GEARBOX
44	AUTOMATIC GEARBOX
47	PROPELLER SHAFTS
51	REAR AXLE AND FINAL DRIVE
54	FRONT AXLE AND FINAL DRIVE
57	STEERING
60	FRONT SUSPENSION
64	REAR SUSPENSION
70	BRAKES
74	WHEELS AND TYRES
76	CHASSIS AND BODY
80	HEATING AND VENTILATION
82	AIR CONDITIONING
84	WIPERS AND WASHERS
86	ELECTRICAL
88	INSTRUMENTS

	01 04 05 07 09
	10
	12
	17 19
	26
	30
	
	41 44
	47 51 54
	57
	60 64 74
	70
	76
	80 82
	84 86 88

Publication Part No. LRL 0088 NAS (2nd Edition)
Published by Rover Technical Communication

© 1996 Rover Group Limited





INTRODUCTION

This workshop manual covers vehicles from 1997 model year onwards. Amendments and additional pages will be issued to ensure that the manual covers latest models. Amendments and additions will be identified by the addition of a dated footer at the bottom of the page.

This Workshop Manual is designed to assist skilled technicians in the efficient repair and maintenance of Land Rover vehicles.

Individuals who undertake their own repairs should have some skill and training, and limit repairs to components which do not affect the safety of the vehicle or its passengers. Any repairs required to safety critical items such as steering, brakes, suspension or supplementary restraint system should be carried out by a Land Rover Dealer. Repairs to such items should NEVER be attempted by untrained individuals.

WARNINGS, CAUTIONS and NOTES are given throughout this Manual in the following form:



WARNING: Procedures which must be followed precisely to avoid the possibility of personal injury.



CAUTION: This calls attention to procedures which must be followed to avoid damage to components.



NOTE: This calls attention to methods which make a job easier or gives helpful information.

DIMENSIONS

The dimensions quoted are to design engineering specification. Alternative unit equivalents have been converted from the original specification.

REFERENCES

References to the left or right hand side in the manual are made when viewing the vehicle from the rear. With the engine and gearbox assembly removed, the coolant pump end of the engine is referred to as the front.

To reduce repetition, operations covered in this Manual do not include reference to testing the vehicle after repair.

It is essential that work is inspected and tested after completion and if necessary a road test of the vehicle is carried out particularly where safety related items are concerned.

REPAIRS AND REPLACEMENTS

When replacement parts are required it is essential that Land Rover parts are used. Attention is particularly drawn to the following points concerning repairs and the fitting of replacement parts and accessories: Safety features embodied in the vehicle may be impaired if other than Land Rover parts are fitted. In certain territories, legislation prohibits the fitting of parts not to the vehicle manufacturer's specification. Torque spanner values given in the Workshop Manual must be strictly adhered to. Locking devices, where specified, must be fitted. If the efficiency of a locking device is impaired during removal it must be replaced with a new one. Certain fasteners must not be re-used. These fasteners are specified in the Workshop Manual.

POISONOUS SUBSTANCES

Many liquids and other substances used are poisonous and therefore must not be consumed. It is also advisable to keep all substances away from open wounds. These substances among others include anti-freeze, brake fluid, fuel, windscreen washer additives, air conditioning refrigerant, lubricants and various adhesives.

FUEL HANDLING PRECAUTIONS

The following information provides basic precautions which must be observed if fuel is to be handled safely. It also outlines the other areas of risk which must not be ignored.

This information is issued for basic guidance only, and in any case of doubt, appropriate enquiries should be made of your local Fire Officer or Fire Department.

Fuel vapour is highly flammable and in confined spaces is also very explosive and toxic.

When fuel evaporates it produces 150 times its own volume in vapour, which when diluted with air becomes a readily ignitable mixture. The vapour is heavier than air and will always fall to the lowest level. It can readily be distributed throughout a workshop by air current, consequently, even a small spillage of fuel is very dangerous.

Always have a fire extinguisher containing **FOAM CO² GAS**, or **POWDER** close at hand when handling fuel, or when dismantling fuel systems and in areas where fuel containers are stored.



WARNING: It is imperative that the battery is not disconnected during fuel system repairs as arcing at the battery terminal could ignite fuel vapour in the atmosphere. Always disconnect the vehicle battery BEFORE carrying out work on the fuel system.

Whenever fuel is being handled, transferred or stored, or when fuel systems are being dismantled all forms of ignition must be extinguished or removed, any leadlamps used must be flame proof and kept clear of spillage.

No one should be permitted to repair components associated with fuel without first having had fuel system training.

Hot fuel handling precautions



WARNING: Before commencing any operation requiring fuel to be drained from the fuel tank, the following procedure must be adhered to:

1. Allow sufficient time for the fuel to cool, thus avoiding contact with hot fuels.
2. Vent the system by removing the fuel filler cap in a well ventilated area. Refit the filler cap until the commencement of fuel drainage.

Fuel transfer



WARNING: Fuel must not be extracted or drained from any vehicle while it is standing over a pit.

The transfer of fuel from the vehicle fuel tank must be carried out in a well ventilated area. An approved transfer tank must be used according to the transfer tank manufacturer's instructions and local regulations, including attention to grounding of tanks.

Fuel tank removal

A **FUEL VAPOUR** warning label must be attached to the fuel tank upon removal from the vehicle.

Fuel tank repair

Under no circumstances should a repair to any tank be attempted.



SYNTHETIC RUBBER

Many 'O' ring seals, flexible pipes and other similar items which appear to be natural rubber are made of synthetic materials called Fluoroelastomers. Under normal operating conditions this material is safe, and does not present a health hazard. However, if the material is damaged by fire or excessive heat, it can break down and produce highly corrosive Hydrofluoric acid which can cause serious burns on contact with skin. Should the material be in a burnt or overheated condition handle only with seamless industrial gloves. Decontaminate and dispose of the gloves immediately after use.

If skin contact does occur, remove any contaminated clothing immediately and obtain medical assistance without delay. In the meantime, wash the affected area with copious amounts of cold water or limewater for fifteen to sixty minutes.

RECOMMENDED SEALANTS

A number of branded products are recommended in this manual for use during maintenance and repair work.

These items include:

HYLOMAR GASKET AND JOINTING COMPOUND
and
HYLOSIL RTV SILICONE COMPOUND.

They should be available locally from garage equipment suppliers.

USED ENGINE OIL



WARNING: Prolonged and repeated contact with engine or motor oil will result in the removal of natural fats from the skin, leading to dryness, irritation and dermatitis.

Used engine oil contains potentially harmful contaminants which may cause skin cancer. Adequate means of skin protection and washing facilities should be provided.

Handling precautions

1. Avoid prolonged and repeated contact with oils, particularly used engine oils.
2. Wear protective clothing, including impervious gloves where applicable.
3. Do not put oily rags in pockets.
4. Avoid contaminating clothes, particularly underwear, with oil.
5. Overalls must be cleaned regularly. Discard unwashable clothing and oil impregnated footwear.
6. First aid treatment must be obtained immediately for open cuts and wounds.
7. Use barrier creams, before each work period, to help the removal of oil from the skin.
8. Wash with soap and water to ensure all oil is removed (skin cleansers and nail brushes will help). Preparations containing lanolin replace the natural skin oils which have been removed.
9. Do not use gasoline, kerosene, diesel fuel, petrol, thinners or solvents for washing the skin.
10. If skin disorders develop, obtain medical advice.
11. Where practicable, degrease components prior to handling.
12. Where there is a risk of eye contact, eye protection should be worn, for example, goggles or face shields; in addition an eye wash facility should be provided.

Disposing of used oils

Environmental protection precaution

It is illegal to pour used oil onto the ground, down sewers or drains, or into waterways.

Dispose of used oil through authorised waste disposal contractors. If in doubt contact your Local Authority for advice on disposal facilities.

ACCESSORIES AND CONVERSIONS

DO NOT FIT unapproved accessories or conversions, as they could affect the safety of the vehicle.

Land Rover will not accept liability for death, personal injury, or damage to property which may occur as a direct result of the fitting of non-approved conversions to the vehicle.

WHEELS AND TYRES



WARNING: DO NOT replace the road wheels with any type other than genuine Land Rover wheels which are designed for multi-purpose on and off road use and have very important relationships with the proper operation of the suspension system and vehicle handling. Replacement tyres must be of the make and sizes recommended for the vehicle, and all tyres must be the same make, ply rating and tread pattern.

STEAM CLEANING

To prevent consequential rusting, any steam cleaning within the engine bay **MUST** be followed by careful re-waxing of the metallic components affected. Particular attention must be given to the steering column, engine coolant pipes, hose clips and ignition coil bracket.

SPECIFICATION

The specification details and instructions set out in this Manual apply only to a range of vehicles and not to any one. For the specification of a particular vehicle purchasers should consult their Dealer

The Manufacturer reserve the right to vary their specifications with or without notice, and at such times and in such manner as they think fit. Major as well as minor changes may be involved in accordance with the Manufacturer's policy of constant product improvement.

Whilst every effort is made to ensure the accuracy of the particulars contained in this Manual, neither the Manufacturer or Dealer, by whom this Manual is supplied, shall in any circumstances be held liable for any inaccuracy or the consequences thereof.

SPECIAL SERVICE TOOLS

The use of approved special service tools is important. They are essential if service operations are to be carried out efficiently, and safely. Where special tools are specified, **only these tools should be used to avoid the possibility of personal injury or damage to the components.** Also the amount of time which they save can be considerable.

Every special tool is designed with the close co-operation of Land Rover, and no tool is put into production which has not been tested and approved by us. New tools are only introduced where an operation cannot be satisfactorily carried out using existing tools or standard equipment. The user is therefore assured that the tool is necessary and that it will perform accurately, efficiently and safely.

Special tools bulletins will be issued periodically giving details of new tools as they are introduced.

All orders and enquiries from the United Kingdom should be sent direct to V. L. Churchill. Overseas orders should be placed with the local V. L. Churchill distributor, where one exists. Countries where there is no distributor may order direct from:

V. L. Churchill Limited,
PO Box 3,
Daventry, Northants,
England, NN11 4NF.

The tools recommended in this Workshop Manual are listed in a multi-language illustrated catalogue, obtainable from:

Messrs. V. L. Churchill at the above address, or from:

Land Rover Publications,
Character Mailing
Haysham Road,
Bootle,
Merseyside, L70 1JL,

COPYRIGHT

© 1996 Rover Group Limited

All rights reserved. No part of this publication may be produced, stored in a retrieval system or transmitted in any form, electronic, mechanical, recording or other means without prior written permission of Rover Group.

JACKING

The following instructions must be carried out before raising the vehicle off the ground.

1. Use a solid level ground surface.
2. Apply parking brake.
3. Select 'P' (Park) in main gearbox.
4. Select Low range in transfer gearbox.



CAUTION: To avoid damage occurring to the under body components of the vehicle the following jacking procedures must be adhered to.

DO NOT POSITION JACKS OR AXLE STANDS UNDER THE FOLLOWING COMPONENTS.

Body structure
Bumpers
Fuel lines
Brake lines
Front radius arms
Panhard rod
Steering linkage
Rear Trailing links
Fuel tank
Engine sump
Gearbox bell housing

Jack or support vehicle by axles only.

Vehicle jack

The jack provided with the vehicle is only intended to be used in an emergency, for changing a tyre. Do **NOT** use the jack for any other purpose. Refer to Owner's Manual for vehicle jack location points and procedure. Never work under a vehicle supported by the vehicle jack.

Hydraulic jack

A hydraulic jack with a minimum 1500 kg, 3,300 lbs load capacity must be used, see J6083.



CAUTION: Do not commence work on the underside of the vehicle until suitable stands have been positioned under the axle.

Raise front of the vehicle

1. Position cup of hydraulic arm under differential casing.



NOTE: The differential casing is not central to the axle. Care should be taken when raising the front road wheels off the ground as the rear axle has less sway stiffness.

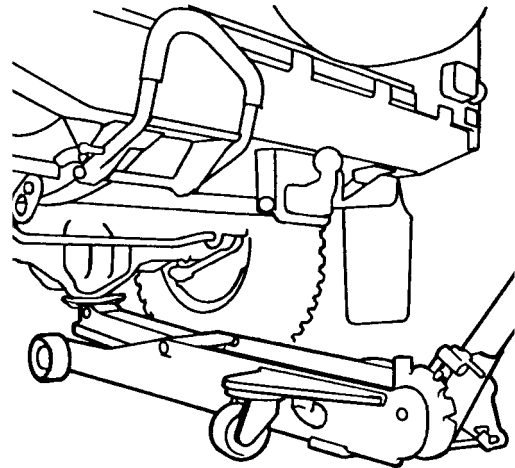

J6083

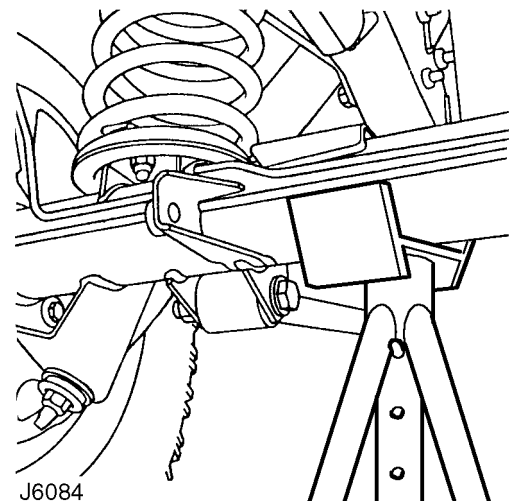

J6084

2. Raise front road wheels to enable an axle stand to be installed under left hand axle tube.
3. Position an axle stand under right hand axle tube, carefully lower jack until axle sits securely on both axle stands, remove trolley jack.

4. Before commencing work on underside of vehicle re-check security of vehicle on stands.
5. Reverse procedure when removing vehicle from stands.

Raise rear of vehicle

1. Position cup of hydraulic arm under differential casing.
2. Raise vehicle to enable axle stands to be installed under left and right hand axle tubes.
3. Lower jack until axle sits securely on axle stands, remove trolley jack.
4. Before commencing work on underside of vehicle re-check security of vehicle on stands.
5. Reverse procedure when removing vehicle from stands.

HYDRAULIC VEHICLE RAMP (FOUR POST)

Use only a 'drive on' type ramp which supports vehicle on its own road wheels. If a 'wheel-free' condition is required, use a 'drive on' ramp incorporating a 'wheel-free' system providing support beneath axle casings. Alternatively, place vehicle on a firm, flat floor and support on axle stands.

TWO POST VEHICLE RAMPS

The manufacturer of LAND ROVER VEHICLES DOES NOT recommend using 'Two Post' ramps employing four adjustable support arms. These are NOT considered safe for Land Rover vehicles. If a vehicle is raised on a Two Post ramp, responsibility for safety of the vehicle and personnel performing service operations lies with the Service Provider.

DYNAMOMETER TESTING



WARNING: DO NOT attempt to drive individual wheels with vehicle supported on floor jacks or stands.

Four wheel dynamometers

Provided that front and rear dynamometer rollers are rotating at identical speeds and that normal workshop safety standards are applied, there is no speed restriction during testing except any that may apply to the tyres.

Two wheel dynamometers

IMPORTANT: Use a four wheel dynamometer for brake testing if possible.

If brake testing on a single axle rig is necessary it must be carried out with propeller shaft to rear axle removed, AND neutral selected in BOTH main gearbox and transfer gearbox. When checking brakes, run engine at idle speed to maintain servo vacuum.

If checking engine performance, the transfer box must be in high range and propeller shaft to stationary axle must be removed.

TOWING

CAUTION: The vehicle has permanent four-wheel drive. The following towing instructions must be adhered to:

Towing the vehicle on all four wheels with driver operating steering and brakes.

1. Turn ignition key to position 'I' to release steering lock.
2. Select neutral in main gearbox and transfer gearbox.

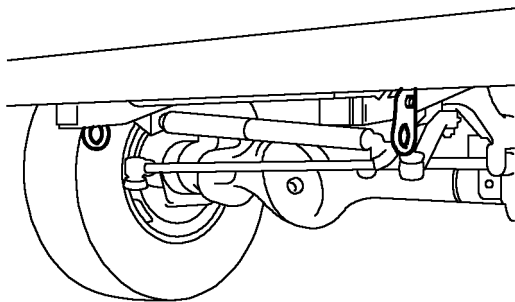

10M0488

3. Secure tow rope, chain or cable to front towing eyes.
4. Release the parking brake.



CAUTION: The brake servo and power assisted steering system will not be functional without the engine running.

Greater pedal pressure will be required to apply the brakes, the steering system will require greater effort to turn the front road wheels. The vehicle tow connection should be used only in normal road conditions, 'snatch' recovery should be avoided.

Suspended tow by breakdown vehicle

1. If the front axle is to be trailed, turn ignition key to position 'I' to release steering lock.
2. Select neutral in main gearbox and transfer gearbox.

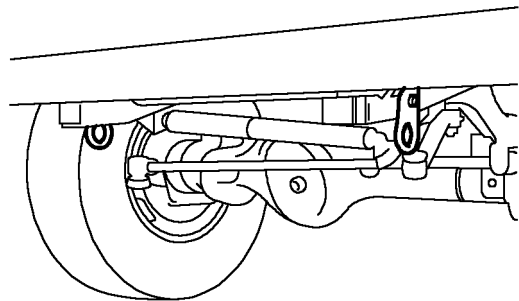

CAUTION: The steering wheel and/or linkage must be secured in a straight ahead position. DO NOT use the steering lock mechanism for this purpose.

TRANSPORTING THE VEHICLE BY TRAILER

10M0488

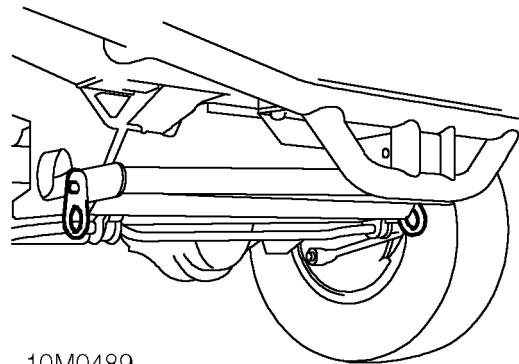

10M0489

Lashing/towing eyes are provided on front and rear of the chassis side members to facilitate the securing of the vehicle to a trailer or other means of transportation.



CAUTION: Underbody components must not be used as lashing points.

Install vehicle on trailer and apply park brake. Select 'N' (Neutral) in main gearbox.

JUMP STARTING

! WARNING: Hydrogen and oxygen gases are produced during normal battery operation. This gas mixture can explode if flames, sparks or lighted tobacco are brought near battery. When charging or using a battery in an enclosed space, always provide ventilation and shield your eyes.

Keep out of reach of children. Batteries contain sulphuric acid. Avoid contact with skin, eyes, or clothing. Also, shield eyes when working near battery to protect against possible splashing of acid solution. In case of acid contact with skin, eyes, or clothing, flush immediately with water for a minimum of fifteen minutes. If acid is swallowed, drink large quantities of milk or water, followed by milk of magnesia, a beaten egg, or vegetable oil. **SEEK MEDICAL AID IMMEDIATELY.**

To Jump Start - Negative Ground Battery

! WARNING: To avoid any possibility of injury use particular care when connecting a booster battery to a discharged battery.

1. Position vehicles so that jump leads will reach, ensuring that vehicles **DO NOT TOUCH**, alternatively a fully charged slave battery may be positioned on floor adjacent to vehicle.
2. Ensuring that ignition and all electrical accessories are switched off, that parking brake is applied and neutral is selected on a manual gearbox, with an automatic gearbox select neutral (N) or park (P) and then connect the jump leads as follows;
 - A. Connect one end of first jumper cable to positive (+) terminal of booster battery.
 - B. Connect other end of first jumper cable to positive (+) terminal of discharged battery.

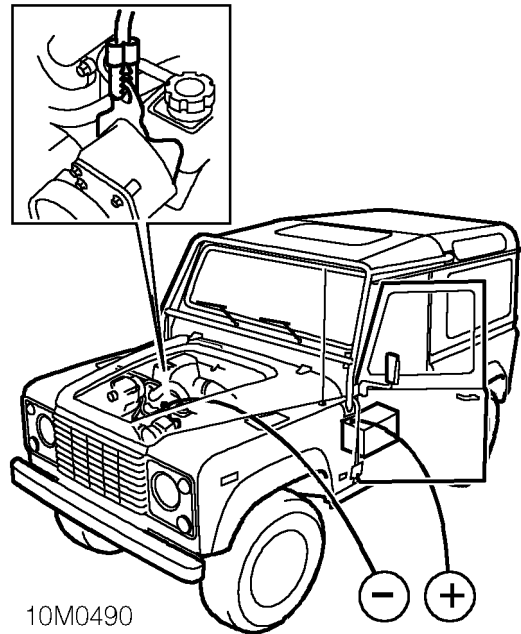

- C. Connect one end of second jumper cable to negative terminal of booster battery.
- D. Connect other end of second jumper cable to a good earth point on the engine, **NOT TO NEGATIVE TERMINAL OF DISCHARGED BATTERY**. Keep jumper lead away from moving parts, pulleys, drive belts and fan blade assembly.

! WARNING: Making final cable connection could cause an electrical arc which if made near battery could cause an explosion.

3. If booster battery is installed in another vehicle, start engine and allow to idle.
4. Start engine of vehicle with discharged battery, following starting procedure in Owners' Manual.

! CAUTION: If vehicle fails to start within a maximum time of 12 seconds, switch ignition off and investigate cause. Failing to follow this instruction could result in irreparable damage to catalyts.

5. Remove negative (-) jumper cable from the engine and then terminal of booster battery.
6. Remove positive (+) jumper cable from positive terminals of booster battery and discharged battery.



ABBREVIATIONS AND SYMBOLS USED IN THIS MANUAL

Across flats (bolt size)	AF	Low tension	l.t.
After bottom dead centre	ABDC	Maximum	max.
After top dead centre	ATDC	Metre	m
Alternating current	a.c.	Millilitre	ml
Ampere	A or amp	Millimetre	mm
Ampere hour	amp hr	Miles per gallon	mpg
Before bottom dead centre	BBDC	Miles per hour	mph
Before top dead centre	BTDC	Minute (angle)	'
Bottom dead centre	BDC	Minus (of tolerance)	-
Brake horse power	bhp	Negative (electrical)	-
British Standards	BS	Newton metres (torque)	Nm
Carbon monoxide	CO	Number	No.
Centimetre	cm	Ohms	ohm
Centigrade (Celsius)	C	Ounces (force)	ozf
Cubic centimetre	cm ³	Ounces (mass)	oz
Cubic inch	in ³	Ounce inch (torque)	ozf.in.
Degree (angle)	deg or °	Outside diameter	O.D.
Degree (temperature)	deg or °	Part number	Part No.
Diameter	dia.	Percentage	%
Direct current	d.c.	Pints	pt
Electronic Control Unit	ECU	Pints (US)	US pt
Electronic Fuel Injection	EFI	Plus (tolerance)	+
Fahrenheit	F	Positive (electrical)	+
Feet	ft	Pound (force)	lbf
Feet per minute	ft/min	Pounds inch (torque)	in.lbf.
Fifth	5th	Pound (mass)	lb
First	1st	Pounds per square inch	PSI or lbf/in ²
Fluid ounce	fl oz	Ratio	:
Foot pounds (torque)	lbf ft	Reference	ref.
Fourth	4th	Revolution per minute	rev/min
Gramme (force)	gf	Right-hand	RH
Gramme (mass)	g	Second (angle)	"
Gallons	gal	Second (numerical order)	2nd
Gallons (US)	US gal	Specific gravity	sp.gr.
High tension (electrical)	H.T.	Square centimetres	cm ²
Internal diameter	I.D.	Square inches	in ²
Inches of mercury	in. Hg	Standard wire gauge	s.w.g.
Inches	in	Synchroniser/Synchromesh	synchro.
Kilogramme (force)	kgf	Third	3rd
Kilogramme (mass.)	kg	Top dead centre	TDC
Kilogramme centimetre (torque)	kgf.cm	United Kingdom	UK
Kilogramme per square millimetre	kgf/mm ²	Vehicle Identification Number	VIN
Kilogramme per square centimetre	kgf/cm ²	Volts	V
Kilogramme metres (torque)	kgf.m	Watts	W
Kilometres	km		
Kilometres per hour	km/h		
Kilovolts	kV		
Left-hand	LH		
Left-hand steering	LHStg		
Left-hand thread	LHThd		
Litres	l or litre		

SCREW THREADS

American Standard Taper Pipe	NPTF
British Standard Pipe	BSP
Unified Coarse	UNC
Unified Fine	UNF

**CROSS REFERENCE OF EMISSION SYSTEM
TERMINOLOGY**

NEW TERM	(ACRONYM)	OLD TERM	(ACRONYM)
Accelerator pedal	(AP)	Throttle pedal	(-)
Air cleaner	(ACL)	Air cleaner	(-)
Air conditioning	(AC)	Air conditioning	(AC)
Battery positive voltage	(B+)	Battery plus, bat +, bat feed	(B+)
Closed loop	(CL)	Closed loop	(-)
Closed throttle position	(CTP)	Closed throttle, idle position	(-)
Canister purge valve	(CANPV)	Charcoal canister purge valve	(-)
Data link connector	(DLC)	Serial link	(-)
Diagnostic trouble code	(DTC)	Fault code	(-)
Distributor ignition	(DI)	Electronic ignition	(-)
Engine control module	(ECM)	Electronic control unit	(ECU)
Engine coolant level	(ECL)	Coolant level	(-)
Engine coolant temperature	(ECT)	Coolant temperature	(temp)
Engine coolant temperature sensor	(ECTS)	Coolant temperature thermistor	(-)
Engine speed	(RPM)	Engine speed	(rev/min)
Evaporative emission system	(EVAP)	Evaporative loss system	(ELC)
Engine fuel temperature sensor	(EFTS)	Fuel temperature thermistor	(-)
4th gear, 3rd gear etc.	(4GR, 3GR)	Fourth gear, 3rd gear	(-)
Fuel pump	(FP)	Fuel pump	(-)
Fan control module	(FCM)	Condenser fan timer	(-)
Generator	(GEN)	Alternator	(-)
Ground	(GND)	Ground, earth	(B-)
Heated oxygen sensor	(H02S)	Lambda (O2) sensor	(-)
Idle air control	(IAC)	Idle speed control	(ISC)
Idle air control valve	(IACV)	Stepper motor	(-)
Ignition control module	(ICM)	Ignition module	(-)
Inertia fuel shutoff	(IFS)	Inertia switch	(-)
Inertia fuel shutoff switch	(IFSS)	Inertia switch	(-)
Intake air temperature	(IAT)	Intake temperature/ambient temperature	(-)
Malfunction indicator lamp	(MIL)	EFI warning lamp	(-)
Manifold vacuum zone	(MVZ)	Manifold depression, vacuum	(-)
Mass air flow sensor	(MAFS)	Air flow meter	(-)
Multipoint fuel injection	(MFI)	Electronic fuel injection	(EFI)
On board diagnostic	(OBD)	Fault code display unit	(-)
Open loop	(OL)	Open loop	(-)
Park/neutral position	(PNP)	Park or neutral	(-)
Park/neutral position switch	(PNPS)	Start inhibit switch	(-)
Programmable read only memory	(PROM)	Chip, PROM	(PROM)
Relay module	(RM)	Relay	(-)
Service reminder indicator	(SRI)	Check engine light	(-)
Solid state relay module	(SSRM)	Control unit	(-)
Three way catalytic converter	(TWC)	Catalyst, catalytic converter	(CAT)
Throttle body	(TB)	Throttle housing	(-)
Throttle position sensor	(TPS)	Throttle potentiometer	(-)
Torque converter clutch	(TCC)	Direct drive clutch	(DDC)
Transmission range	(TR)	Transmission gear	(-)
Transmission range selector	(TRS)	Shift lever, shifter	(-)
Vehicle speed sensor	(VSS)	Road speed transducer	(-)
Wide open throttle	(WOT)	Full throttle, wide open throttle	(WOT)

VEHICLE IDENTIFICATION NUMBER (VIN)

An adhesive label containing the Vehicle Identification Number, date of manufacture and gross axle weight ratings is positioned in a recess on the LH side of the driver's footwell. The information also includes wheel and tyre sizes and tyre pressures at gross axle weight ratings.

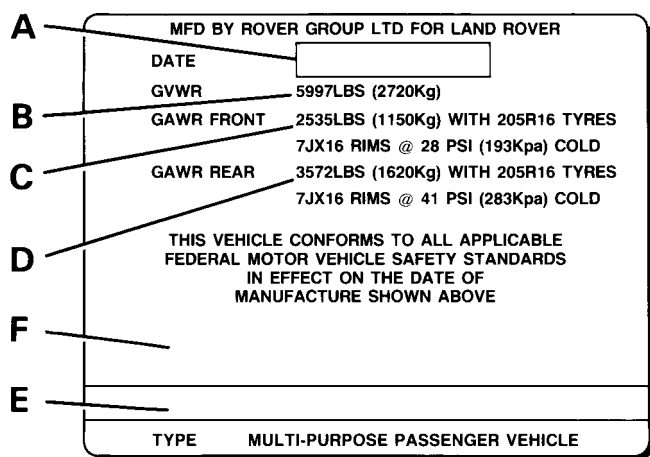

RR2944E

Key to vehicle identification label

- A. Month and year of manufacture
- B. Gross vehicle weight rating
- C. Gross axle weight rating for front axle
- D. Gross axle weight rating for rear axle
- E. Vehicle identification number (17 digits)
- F. Vehicle identification number - bar code

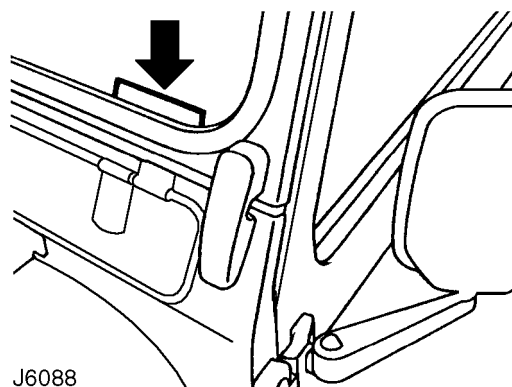

The VIN is also stamped on a plate visible through the LH side of the windscreen.

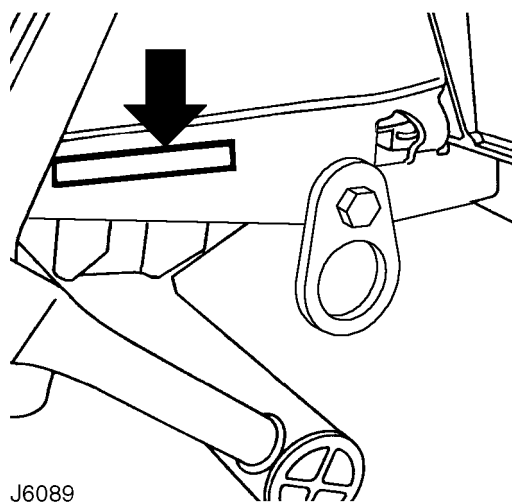

The number is also stamped on the RH side of the chassis to the rear of the front lashing eye.

LOCATION OF IDENTIFICATION NUMBERS

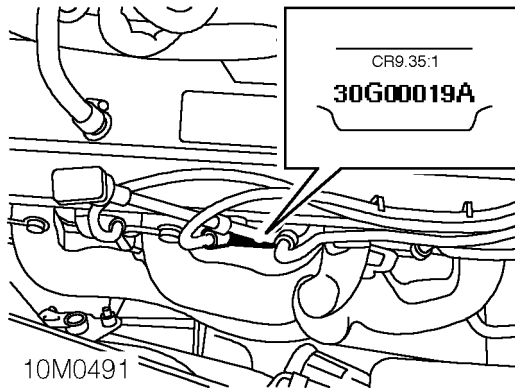
**Engine serial number - V8i engine**

Stamped on a cast pad on the cylinder block, between numbers 3 and 5 cylinders.

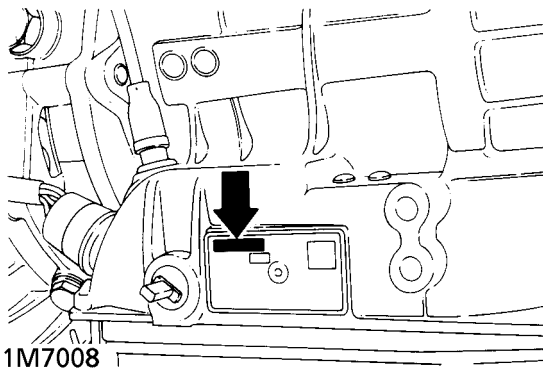

NOTE: The appropriate engine compression ratio is stamped above the serial number.

**Automatic gearbox serial number**

The serial number is stamped on a plate attached to the LH side of the casing.

Transfer gearbox serial number

The serial number is stamped on the LH side of the gearbox casing below the mainshaft rear bearing housing adjacent to the bottom cover, see J6092

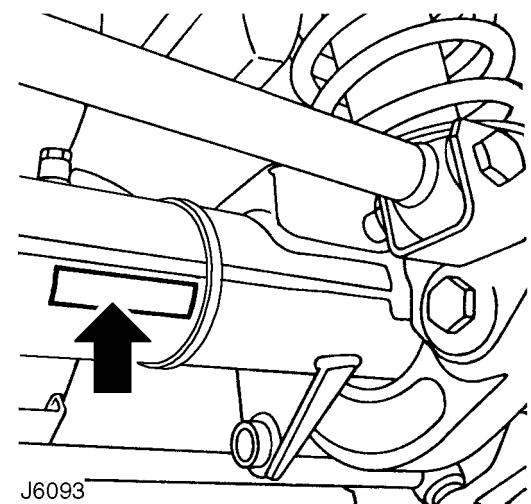
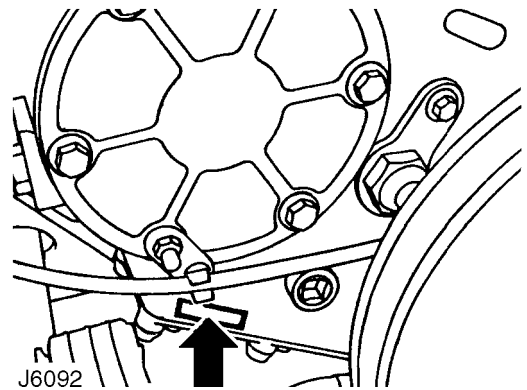
**Front axle serial number**

Serial number is stamped on the front of LH axle tube.

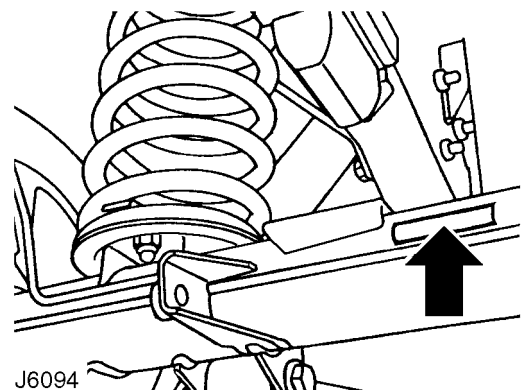
**Rear axle serial number**

Serial number is stamped on rear of LH axle tube.

FAULT DIAGNOSTIC EQUIPMENT

TestBook

Land Rover Vehicles are equipped with substantial electronics to provide the best performance from the vehicles systems.

Diagnostic equipment named TestBook is available to expand the diagnostic abilities of the dealer workshop. This repair manual is produced with TestBook in mind.

Features of TestBook include :-

- Fully upgradable support for the technician.
- Structured diagnostics to accommodate all skill levels.
- Touch screen operation.
- Direct print out of screen information and test results.

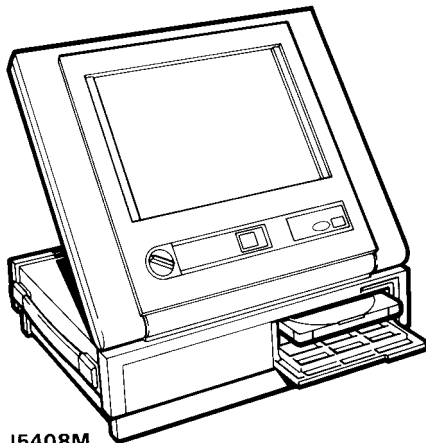

J5408M

ELECTRICAL REFERENCE LIBRARY

The Electrical Reference Library is a separate publication intended for use by trained Land Rover technicians as an aid to diagnosing electrical faults.

READING THIS MANUAL

This manual is divided into sections shown on the contents page, alongside a range of icons, familiar to service technicians.

Relevant information is contained within each of these sections. These are further divided into the following sub-sections which appear at the foot of each page :-

Description and operation.

Fault diagnosis.

Adjustment.

Repair.

Overhaul.

Specifications, Torque.

To avoid repeating information through the sections, where part of the repair operation impacts on another section, a cross reference is given to direct the reader to where the information is sited.

For example:

The maintenance section states the need to renew auxiliary drive belt. A cross reference sites this information in:

Section: Electrical

- Sub-section: Repairs

- Heading: Auxiliary drive belt

American terminology.

A few words used in this manual differ to words used in America. Where this occurs the American word is placed inside square brackets. For example: bonnet [hood], wing [fender], ramp [hoist].

ENGINE 4.0 V8i

Type	V8i	
Number of cylinders	Eight, two banks of four	
Bore	94,00 mm	3.70 in
Stroke	71,12 mm	2.80 in
Capacity	3950 cm ³	241 in ³
Compression ratio	9.35:1	
Valve operation	Overhead by push-rod	
Maximum power	140kW at 4750 rev/min	

Crankshaft

Main journal diameter	63,500-63,487 mm	2.500-2.4995 in
Minimum regrind diameter	62,471-62,484 mm	2.459-2.260 in
Maximum out of round	0,040 mm	0.0016 in
Crankpin journal diameter	55,513-55,500 mm	2.1855-2.1850 in
Minimum regrind diameter	54,484-54,497 mm	2.1450-2.1455 in
Crankshaft end thrust - end float		
Taken on thrust washers of centre main bearing	0,10-0,20 mm	0.004-0.008 in
Maximum run-out	0,08 mm	0.003 in

Main bearings

Number and material	5, Lead-indium overlay	
Diametrical clearance	0,015-0,060 mm	0.0006-0.0024 in
Undersize bearing shells	0,254 mm, 0,508 mm	0.010 in, 0.020 in

Connecting rods

Type	Horizontally split big-end, plain small-end	
Length between centres	155,12-155,22 mm	6.107-6.111 in

Big-end bearings

Type and material	Lead-indium overlay	
Diametrical clearance	0,015-0,060 mm	0.0006-0.0024 in
End-float crankpin	0,15-0,36mm	0.006-0.014 in
Undersize bearing shells	0,25 mm, 0,50 mm	0.010, 0.020 in

Piston/gudgeon pins

Length	60.00-60,50 mm	2.362-2.382 in
Diameter	23,995-24,000 mm	0.9447-0.9449 in
Fit-in connecting rod	Press fit	
Clearance in piston	0,006-0,015 mm	0.0002-0.0006 in

Pistons

Clearance in bore, measured at bottom
of skirt at right angles to piston pin 0,020-0,050 mm 0.0008-0.0020 in

Piston rings

Number of compression rings 2
 Number of control rings 1
 No 1 compression ring Molybdenum barrel faced
 No 2 compression ring Tapered and marked 'T' or 'TOP'
 Width of compression rings 1,48-1.49 mm 0.058-0.059 in
 Top 1,21-1,23 mm 0.047-0.048 in
 Compression ring gap 0,40-0,65 mm 0.016-0.26 in
 Top 0.3-0.5 mm 0.012-0.020 in
 Oil control ring type Aclonofom
 Oil control ring width 3,0 mm 0.118 in
 Oil control ring rail gap 0,38-1,40 mm 0.015-0.055 in

Camshaft

Location Central
 Number of bearings 5
 Bearing type Tin-aluminium - Non serviceable
 Camshaft end-float 0.
 Drive Chain 9,52 mm pitch x 54 pitches.

Tappets

Type Hydraulic-self-adjusting

Valves

Length: Inlet 116,59-117,35 mm 4.590-4.620 in
 Exhaust 116,59-117,35 mm 4.590-4.62 in
 Seat angle: Inlet 45°to 45°25'
 Exhaust 45°to 45°25'
 Head diameter: Inlet 39,75-40,00 mm 1.565-1.575 in
 Exhaust 34,23-34,48 mm 1.347-1.357 in
 Stem diameter: Inlet 8,664-8,679 mm 0.341-0.342 in
 Exhaust 8,651-8,666 mm 0.340-0.341 in
 Stem to guide clearance: Inlet 0,025-0,066 mm 0.001-.0026 in
 Exhaust 0,038-0,078 mm 0.0015-0.003 in
 Valve lift (Inlet and Exhaust) 9,94 mm 0.391 in
 Valve spring fitted length at pressure of 29,5 kg, 65 lb 40,4 mm 1.590 in

Lubrication

System type Wet sump, pressure fed
 Oil pump type Eccentric rotor
 Oil pressure at 2400 rev/min with engine
at running temperature 2.1 - 2.8 bar 30 - 40 lb/in²
 Oil filter - internal Wire screen, pump intake filter.
 Oil filter - external Full flow, self-contained cartridge



ENGINE MANAGEMENT SYSTEM (GEMS)

Fuel system type Sagam-Lucas Gems hot wire system electronically controlled
 Fuel pump-make/type High pressure electrical, immersed in the fuel tank
 Fuel pump delivery pressure 2.4-2.6 bar 34-37 lbf/in²
 Fuel filter In-line filter 'canister' type

Mass air flow sensor (MAF)

Make and type Lucas 'Hot Wire' 20AM

Injectors

Make and type Lucas D1000

Engine Control Module (ECM)

Make and type Lucas GEMS 8.2

Fuel pressure regulator

Make and type Lucas 8RV

Fuel temperature sensor

Make and type Lucas 6TT

Coolant temperature sensor

Make and type Lucas 8TT

Bypass air valve (Stepper motor)

Make and type Lucas 3ACM

Throttle position sensor

Make and type Lucas 3TP

Heated oxygen sensor

Make and type Lucas 4LS - heated

Camshaft position sensor

Make and Land Rover part no. Honeywell ERR2261

Crankshaft position sensor

Make and type Lucas 4CS

Knock sensor

Make and type Lucas 2KS

Intake air temperature sensor

Make and type Lucas 10TT

Ignition coils

Make and type Lucas 2DIS2

COOLING SYSTEM

Type Pressurized system with cross-flow radiator and remote header tank, thermostat control, pump and fan assisted. Water and antifreeze mixture as coolant.

Type of pump Centrifugal impellor, belt driven

Thermostat 88°C 190°F

Expansion tank cap pressure - system pressure 1.0 bar 15 lbf/in²

Fan and viscous coupling assembly 11 blade axial flow 433mm, 17 in diameter.



AUTOMATIC TRANSMISSION

Automatic gearbox

Model ZF4HP22
 Type Four speed and reverse epicyclic gears with fluid torque converter and lock-up

Transfer gearbox

LT230Q Two speed reduction on main gearbox output, front and rear drive permanently engaged.

Transfer gearbox ratios:

High 1.211:1
 Low 3.269:1

Automatic gearbox ratios

4th 0.728:1
 3rd 1.000:1
 2nd 1.480:1
 1st 2.480:1
 Reverse 2.086:1

Overall ratios - final drive High transfer Low transfer

4th	3.46:1	9.34:1
3rd	4.75:1	12.83:1
2nd	7.03:1	18.98:1
1st	11.78:1	31.80:1
Reverse	9.91:1	26.75:1

Propeller shafts

Type
 Front Solid bar 28.6mm, 1.125 in diameter
 Rear Tubular 51mm, 2.00 in diameter
 Universal joints Open type Hookes O3EHD

Rear axle

Type Spiral bevel, fully floating shafts
 Ratio 3.54:1

Front axle

Type Spiral bevel, enclosed constant velocity joints, fully floating shafts
 Angularity of universal joint on full lock 32°
 Ratio 3.54:1

SHIFT SPEEDS - AUTOMATIC ZF

OPERATION	SELECTOR POSITION	VEHICLE SPEED APPROX		ENGINE SPEED APPROX RPM
KICKDOWN (KD)				
		MPH	KPH	
KD4 - 3	D	92 - 100	149 - 164	
KD3 - 2	3(D)	57 - 62	99 - 108	
KD2 - 1	2(D,3)	30 - 37	48 - 61	
KD3 - 4	D	N/A	N/A	
KD2 - 3	D(3)	66 - 69	105 - 114	4750 - 5200
KD1 - 2	D(3,2)	37 - 44	61 - 70	4600 - 5250
FULL THROTTLE (FT)				
FT4 - 3	D	67 - 73	107 - 118	
FT3 - 2	3(D)	44 - 53	70 - 80	
FT3 - 4	D	81 - 88	130 - 141	3980 - 4330
FT2 - 3	D(3)	60 - 66	96 - 105	4350 - 4800
FT1 - 2	D(3,2)	32 - 37	52 - 61	3950 - 4650
PART THROTTLE (PT)				
PT4 - 3	D	51 - 60	82 - 94	
PT3 - 2	D(3)	32 - 41	53 - 65	
PT2 - 1	D(3,2)	11 - 13	18 - 21	
LIGHT THROTTLE (LT)				
LT3 - 4	D	28 - 33	47 - 54	1430 - 1650
LT2 - 3	D(3)	20 - 24	32 - 38	1420 - 1820
LT1 - 2	D(3,2)	10 - 11	15 - 18	1180 - 1220
ZERO THROTTLE (ZT)				
ZT4 - 3	D	21 - 27	34 - 45	
ZT3 - 2	D(3)	13 - 16	21 - 26	
ZT2 - 1	D(3,2)	7 - 8	11 - 12	
TORQUE CONVERTER				
Lock up (IN)	D	56 - 59	89 - 94	1875 - 2000
Unlock (OUT)	D	54 - 57	85 - 91	1825 - 1930

NOTE: The speeds given in the above chart are approximate and only intended as a guide. Maximum shift changes should take place within these tolerance parameters.



STEERING

Power steering box

Make and type Adwest Varamatic - worm and roller box
 Ratio Variable: straight ahead 19.3:1 to 17.2:1 on lock
 Steering wheel turns lock to lock 3.75

Steering pump

Make and type ZF Unicorn
 Operating pressure: **bar**
 Straight ahead at idle - max 7.0 100
 Full lock, left or right at idle - min 28 400
 Full lock, left or right at 1000 rev/min 70-77 1000-1100

Steering geometry

Steering wheel diameter 412mm 16.25 in
 Steering column type Collapsible coupling
 Steering damper Double acting fitted between drag link and pinion housing
 Toe-out - measurement 0 to 2.0mm 0 to 0.08 in
 Toe-out - included angle 0° to 0° 20'
 Camber angle 0° *
 Castor angle 3° *
 Swivel pin inclination 7° *

* Check with vehicle in static unladen condition with 23 l, 6 US gal of fuel. Rock the vehicle up and down at the front to allow the suspension to take an unstressed position.

SUSPENSION

Type Coil springs controlled by telescopic dampers front and rear.
 Front Transverse location of axle by Panhard rod, and fore and aft location by two radius arms. Anti-roll bar fitted.
 Rear Fore and aft movement inhibited by two tubular trailing links. Lateral location of axle by a centrally positioned 'A' frame, upperlink assembly, bolted at the apex to a ball joint mounting. Anti-roll bar fitted.

Road spring data

90 model weight 2550 Kg 5622 lb
 Front
 Driver side NRC 9446 BLUE/GREEN
 Passenger side NRC 9447 BLUE/YELLOW
 Rear
 Driver side NRC 9448 RED/BLUE
 Passenger side NRC 9449 YELLOW/WHITE

Shock absorbers

Type	Telescopic, double-acting non-adjustable	
Bore diameter	35.47mm	1.396 in

BRAKES**Front service brake**

Caliper	AP Lockheed, four opposed pistons	
Operation	Hydraulic, self adjusting	
Disc	Ventilated, outboard	
Disc diameter	298mm	11.73 in
Disc thickness	24mm	0.945 in
Wear limit - per side of disc	1mm	0.04 in
Disc run-out maximum	0.15mm	0.006 in
Pad area	58cm ²	9.0 in ²
Total swept area - per disc	801cm ²	124 in ²
Pad material	Ferodo 3440FM non asbestos	
Pad minimum thickness	3mm	0.12 in

Rear service brake

Caliper	AP Lockheed opposed piston	
Operation	Hydraulic, self adjusting	
Disc	Solid, outboard	
Disc diameter	290mm	11.42 in
Disc thickness	12.5mm	0.490 in
Wear limit - per side of disc	0.38mm	0.015 in
Disc run-out maximum	0.15mm	0.006 in
Pad area	30.5cm ²	4.73 in ²
Total swept area - per disc	694cm ²	106.98in ²
Pad minimum thickness	3mm	0.12 in
Pad material	Ferodo 3440FM non asbestos	

Parking brake

Type	Mechanical, cable operated drum brake on the rear of the transfer gearbox output shaft	
Drum internal diameter	254 mm	10.0 in
Width	70mm	2.75 in
Pad material	Ferodo 3611 non asbestos	

Servo/master cylinder

Manufacturer	Lucas	
Servo type	LSC 80, ratio 4.0:1	
Master cylinder tandem type - diameter	25.4 mm	1.0 in
Pressure reducing valve, failure conscious:		
Cut-in pressure	24 bar	360 lbf/in ²



AIR CONDITIONING

System	CFC free expansion valve system	
Compressor	Nippon Denso 10PA17	
Refrigerant	R134a	
Charge quantity	900 gm ± 30 gm	32 oz ± 1 oz
Refrigerant oil	180 ml	6.3 oz

WIPER MOTORS

Windscreen wiper motor

Make/type	Lucas 14W uprated two speed	
Armature end float	0.1 to 0.2 mm	0.004 to 0.008 in
Brush length, minimum	4.8 mm	0.20 in
Brush spring tension	140 to 200 g	5 to 7 oz
Resistance of armature winding at 16fC, 68fF measured between adjacent commutator segments	0.23 to 0.35 ohms	
Light running, rack disconnected: current at 13.5 V	2.0 A	
Wiper speed, wet screen, 60 seconds from cold:		
Low speed	45 ± 3 rev/min	
High speed	65 ± 5 rev/min	

Tailgate wiper motor

Make/type	IMOS (non-serviceable)	
Running current, wet screen at 20°C, 68°F ambient	1.0 to 2.8 A	
Wiper speed, wet screen at 20°C, 68°F ambient	37 to 43 cycles per minute	

ELECTRICAL

System 12 volt, negative ground

Battery

Make Land Rover Parts and Equipment
Lucas maintenance free
Type - standard 9-plate 371
Type - heavy duty 13-plate 389

Generator

Manufacturer Magnetti Marelli
Type A127 - 100amp
Polarity Negative ground
Brush length:
 New 17 mm 0.67 in
 Worn, minimum free protrusion from moulding 5 mm 0.20 in
Brush spring pressure flush with moulding 1.3 to 2.7N 0.25 to 0.60 lbf
Regulator voltage 13.6 to 14.4 volts
Nominal output:
 Generator speed 6000 rev/min
 Control at 14 V 65 A

Starter motor

Make and type Magnetti Marelli M78R pre-engaged
Brush spring tension 1020 gr 16 ozf
Brush minimum length 9.5 mm 0.07 in

Fuses

Type Autofuse (blade type)
Blow ratings to suit individual circuits

Horns

Make/type Klamix (Mixo) TR99



BULBS

Exterior**Type**

Headlamps	12V -60/55W Halogen
Front pilot lamps	12V -5W bayonet capless
Side marker lamps	12V -3.5W capless
Tail/Stop lamps	12V -5W/21W bayonet
Stop lamps	12V -21W bayonet
High level stop lamp, soft top	12V -5W capless
High level stop lamp, hard top	12V -21W bayonet
Direction indicator lamps	12V -21W bayonet
Number plate lamp	12V -5W capless
Reverse lamp	12V -21W bayonet
Rear fog guard lamp	12V -21W bayonet

Interior**Type**

Interior roof lamps	12V -10W festoon
Instrument illumination	12V -1.2W capless
Warning light panel	12V -1.2W bulb/holder unit
Hazard warning switch	12V -1.2W capless



CAUTION: The fitting of new bulbs with wattages in excess of those specified will result in damage to vehicle wiring and switches.

VEHICLE WEIGHTS AND PAYLOAD

When loading a vehicle to its maximum Gross Vehicle Weight (GVW), consideration must be taken of the unladen vehicle weight and the distribution of the payload to ensure that axle loadings do not exceed the permitted maximum values.

It is the customer's responsibility to limit the vehicle's payload in an appropriate manner such that neither maximum axle loads nor GVW are exceeded.

VEHICLE CURB WEIGHTS

Curb weight = Vehicle weight + Full fuel tank (no occupants or pay load)

Soft top:	1710 Kg	3768 lb
Hard top:	1770 kg	3902 lb
Gross vehicle weight	2720 Kg	6001 lb

VEHICLE GROSS AXLE WEIGHTS

Front axle (GAWF)	1225 Kg	2701 lb
Rear axle (GAWR)	1495 kg	3300 lb



NOTE: Axle weights are not additive. The individual maximum axle weights and gross vehicle weight must not be exceeded.

TOWING WEIGHTS

	On-road	Off-road
Unbraked trailers	750 Kg, 1653 lb	500 Kg, 1102 lb
Trailers with overrun brakes	3500 Kg, 8818 lb	1000 Kg, 2204 lb
4 wheel trailers with coupled brakes *	4000 kg, 8818 lb	1000 kg, 2204 lb
Nose weight	160 kg, 350 lb	160 kg, 350 lb



NOTE: * Only applies to vehicles modified to accept coupled brakes.



NOTE: All weight figures are subject to local restrictions.



OFF-ROAD PERFORMANCE

Curb weight, full fuel tank and 75 kg, 150 lb:

Max. gradient	45fl	
Approach angle	51fl	
Departure angle	35fl	
Wading depth	500 mm	20 in
Min. ground clearance (unladen):	229 mm	9.0 in
Ramp break over angle	146fl	



NOTE: Departure angles do not account for the addition of a tow hitch.

WHEELS AND TYRES

Wheel size - Alloy	7J X 16	
Tyre size	265/75 - R16 MULTI-TERRAIN	
Tyre pressures:		
	Front	Rear
Normal - all load conditions	265/75 R16 All Terrain	
Front	1,9 bar	28 lbf/in ²
Rear	2,4 bar	35 lbf/in ²
Soft ride*		
Front	1.6 bar	23 lbf/in ²
Rear	2,1 bar	30 lbf/in ²

* Soft ride pressure is for limited use only and MUST NOT be used above 55 mph, 85 km/h.



WARNING: Tyre pressures must be checked with the tyres cold, as the pressure is about 0.2 bar, 3 lbf/in² higher at running temperature. If the vehicle has been parked in the sun or high ambient temperatures, DO NOT reduce the tyre pressures, move the vehicle into the shade and wait for the tyres to cool before checking the pressures.



WARNING: Always use the same make and type of radial-ply tyres, front and rear. DO NOT use cross-ply tyres, or interchange tyres from front to rear. If the wheel is marked 'TUBELESS', an inner tube must NOT be fitted.

VEHICLE DIMENSIONS

Overall length:		
Soft top	3722 mm	146.5 in
Hard top	3883 mm	152.9 in
Overall width (excluding mirrors):	1790 mm	70.5 in
Overall height:		
Soft top	1965 mm	77.4 in
Hard top	1972 mm	77.6 in
Wheelbase	2360 mm	92.9 in
Track front/rear	1486 mm	58.5 in
Interior width between wheel boxes	925 mm	36.4 in
Turning circle	12.65m	41ft 6in



ENGINE 4.0 V8

Type 4.0 Litre V8

Firing order 1-8-4-3-6-5-7-2

Cylinder Numbers

Left bank 1-3-5-7

Right bank 2-4-6-8

No 1 Cylinder location Pulley end of left bank

Spark plugs

Make/type Champion RN11YCC

Gap 0.90 - 1.00 mm 0.035 - 0.040 in

Coils

Make Lucas 2D1S2

Type Double ended coil, bank of 4

Compression ratio 9.35:1 - High Compression

Fuel injection system

Make Sagem - Lucas

Type GEMS Sequential Multipoint Fuel injection (SFi)
Hot-wire air flow sensor system electronically
controlled

Valve Timing

Opens 28°BTDC

Closes 77°ABDC

Duration 285°

Valve peak 108°ATDC

Exhaust

66°BBDC

39°ATDC

285°

110°BTDC

Idle speed - controlled by GEMS system

All loads off 700 ± 20 rev/min

Base idle speed Not adjustable

Idle air control valve position Checked via **TestBook**

CO at idle Less than 0.5%

Gasoline

9.35:1 - USA vehicles PREMIUM UNLEADED GASOLINE (PUG)
with a CLC or AKI octane rating of 90 or 92.



GENERAL FITTING REMINDERS

WORKSHOP SAFETY IS YOUR RESPONSIBILITY!

The suggestions, cautions and warnings in the section are intended to serve as reminders for trained and experienced mechanics. This manual is not a definitive guide to automotive mechanics or workshop safety.

Shop equipment, shop environment, and the use and disposal of solvents, fluids, and chemicals are subject to government regulations which are intended to provide a level of safety. It is your responsibility to know and comply with such regulations.

PRECAUTIONS AGAINST DAMAGE

1. Always fit covers to protect fenders before commencing work in engine compartment.
2. Cover seats and carpets, wear clean overalls and wash hands or wear gloves before working inside vehicle.
3. Avoid spilling hydraulic fluid or battery acid on paint work. Wash off with water immediately if this occurs. Use Polythene sheets to protect carpets and seats.
4. Always use a recommended Service Tool, or a satisfactory equivalent, where specified.
5. Protect temporarily exposed screw threads by replacing nuts or fitting plastic caps.

SAFETY PRECAUTIONS

1. Whenever possible, use a lift when working beneath vehicle in preference to jacking. Chock wheels as well as applying parking brake.



WARNING: Do not use a pit when removing fuel system components.

2. Never rely on a jack alone to support vehicle. Use axle stands carefully placed at jacking points to provide rigid support.
3. Ensure that a suitable form of fire extinguisher is conveniently located.
4. Check that any lifting equipment used has adequate capacity and is fully serviceable.
5. Disconnect battery negative lead.



WARNING: Do not disconnect any pipes in air conditioning system, unless trained and instructed to do so. A refrigerant is used which can cause blindness if allowed to contact eyes.

6. Ensure that adequate ventilation is provided when volatile degreasing agents are being used.
7. Do not apply heat in an attempt to free stiff fixings; as well as causing damage to protective coatings, there is a risk of damage to electronic equipment and brake linings from stray heat.

PREPARATION

1. Clean components and surrounding area prior to removal. Before removing a component, clean it and its surrounding areas as thoroughly as possible.
2. Blank off any openings exposed by component removal, using greaseproof paper and masking tape.
3. Immediately seal fuel, oil or hydraulic lines when separated, using plastic caps or plugs, to prevent loss of fluid and entry of dirt.
4. Close open ends of oilways, exposed by component removal, with tapered hardwood plugs or readily visible plastic plugs.
5. Immediately a component is removed, place it in a suitable container; use a separate container for each component and its associated parts.
6. Before dismantling a component, clean it thoroughly with a recommended cleaning agent; check that agent is suitable for all materials of component.
7. Clean bench and provide marking materials, labels, containers and locking wire before dismantling a component.

INSPECTION-GENERAL

1. Never inspect a component for wear or dimensional check unless it is absolutely clean; a slight smear of grease can conceal an incipient failure.
2. When a component is to be checked dimensionally against figures quoted for it, use correct equipment (surface plates, micrometers, dial gauges, etc.) in serviceable condition. Makeshift checking equipment can be dangerous.
3. Reject a component if its dimensions are outside limits quoted, or if damage is apparent. A part may, however, be refitted if its critical dimension is exactly limit size, and is otherwise satisfactory.
4. Use 'Plastigauge' 12 Type PG-1 for checking bearing surface clearances. Directions for its use, and a scale giving bearing clearances in 0,0025 mm steps are provided with it.

DISMANTLING

1. Observe scrupulous cleanliness when dismantling components, particularly when brake, fuel or hydraulic system parts are being worked on. A particle of dirt or a cloth fragment could cause a dangerous malfunction if trapped in these systems.
2. Blow out all tapped holes, crevices, oilways and fluid passages with an air line. Ensure that any O-rings used for sealing are correctly replaced or renewed, if disturbed.
3. Use marking ink to identify mating parts, to ensure correct reassembly. If a centre punch or scriber is used they may initiate cracks or distortion of components.
4. Wire together mating parts where necessary to prevent accidental interchange (e.g. roller bearing components).
5. Wire labels on to all parts which are to be renewed, and to parts requiring further inspection before being passed for reassembly; place these parts in separate containers from those containing parts for rebuild.
6. Do not discard a part due for renewal until it has been compared it with the new part, to ensure the correct replacement has been obtained.

BALL AND ROLLER BEARINGS



CAUTION: Never refit a ball or roller bearing without first ensuring that it is in a fully serviceable condition.

1. Remove all traces of lubricant from bearing under inspection by washing in a suitable degreaser; maintain absolute cleanliness throughout operations.
2. Inspect visually for markings of any form on rolling elements, raceways, outer surface of outer rings or inner surface of inner rings. Reject any bearings found to be marked, since any marking in these areas indicates onset of wear.
3. Holding inner race between finger and thumb of one hand, spin outer race and check that it revolves absolutely smoothly. Repeat, holding outer race and spinning inner race.
4. Rotate outer ring gently with a reciprocating motion, while holding inner ring; feel for any check or obstruction to rotation, and reject bearing if action is not perfectly smooth.
5. Lubricate bearing generously with lubricant appropriate to installation.
6. Inspect shaft and bearing housing for discoloration or other marking suggesting that movement has taken place between bearing and seatings. (This is particularly to be expected if related markings were found in operation 2).
7. Ensure that shaft and housing are clean and free from burrs before fitting bearing.

8. If one bearing assembly of a pair shows an imperfection it is generally advisable to replace both with new bearings; an exception could be made if the faulty bearing had covered a low mileage, and it could be established that damage was confined to it only.
9. When fitting bearing to shaft, apply force only to inner ring of bearing, and only to outer ring when fitting into housing.

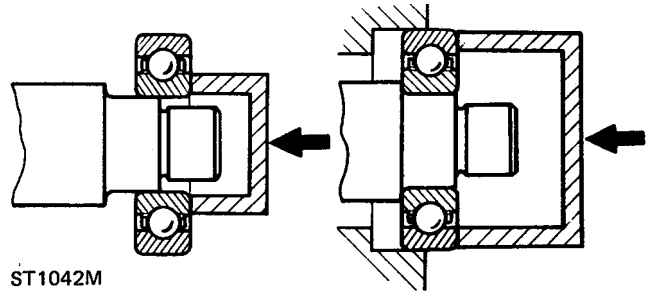

ST11042M

10. In the case of grease lubricated bearings (e.g. hub bearings) fill space between bearing and outer seal with recommended grade of grease before fitting seal.
11. Always mark components of separable bearings (e.g. taper roller bearings) in dismantling, to ensure correct reassembly. Never fit new rollers in a used outer ring, always fit a complete new bearing assembly.

OIL SEALS



NOTE: Ensure that the seal running track is free from pits, scores, corrosion and general damage prior to fitting replacement seal.

replacement seal.

1. Always fit new oil seals when rebuilding an assembly.
2. Carefully examine seal before fitting to ensure that it is clean and undamaged.
3. Coat the sealing lips with clean grease; pack dust excluder seals with grease, and heavily grease duplex seals in cavity between sealing lips.
4. Ensure that seal spring, if provided, is correctly fitted.
5. Place lip of seal towards fluid to be sealed and slide into position on shaft, using fitting sleeve when possible to protect sealing lip from damage by sharp corners, threads or splines. If fitting sleeve is not available, use plastic tube or tape to prevent damage to sealing lip.

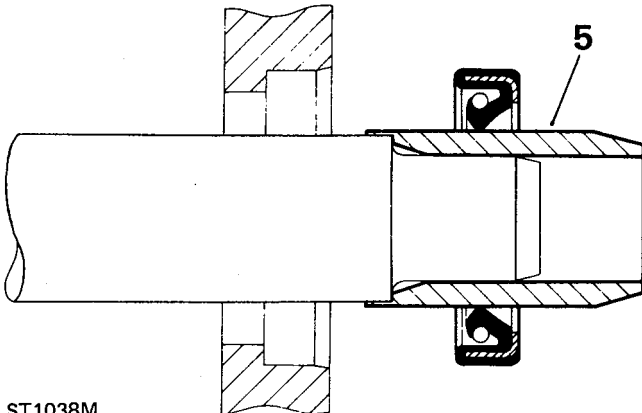

ST1038M

6. Grease outside diameter of seal, place square to housing recess and press into position, using great care and if possible a 'bell piece' to ensure that seal is not tilted. (In some cases it may be preferable to fit seal to housing before fitting to shaft). Never let weight of unsupported shaft rest in seal.

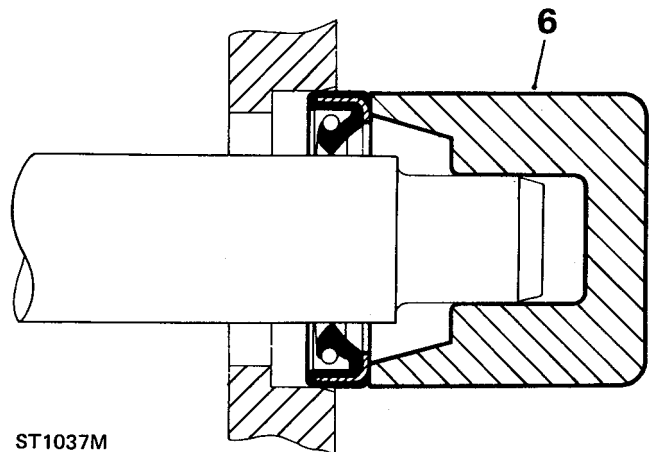

ST1037M

7. If correct service tool is not available, use a suitable drift approximately 0.4mm (0.015 in) smaller than outside diameter of seal. Use a hammer **VERY GENTLY** on drift if a press is not suitable.
8. Press or drift seal in to depth of housing if housing is shouldered, or flush with face of housing where no shoulder is provided. Ensure that the seal does not enter the housing in a tilted position.



NOTE: Most cases of failure or leakage of oil seals are due to careless fitting, and resulting damage to both seals and sealing surfaces. Care in fitting is essential if good results are to be obtained. **NEVER** use a seal which has been improperly stored or handled, such as hung on a hook or nail.



JOINTS AND JOINT FACES

1. Always use correct gaskets where they are specified.
2. Use jointing compound only when recommended. Otherwise fit joints dry.
3. When jointing compound is used, apply in a thin uniform film to metal surfaces; take great care to prevent it from entering oilways, pipes or blind tapped holes.
4. Remove all traces of old jointing materials prior to reassembly. Do not use a tool which could damage joint faces.
5. Inspect joint faces for scratches or burrs and remove with a fine file or oil stone; do not allow removed material or dirt to enter tapped holes or enclosed parts.
6. Blow out any pipes, channels or crevices with compressed air, fit new 'O' rings or seals displaced by air blast.

FLEXIBLE HYDRAULIC PIPES, HOSES

1. Before removing any brake or power steering hose, clean end fittings and area surrounding them as thoroughly as possible.
2. Obtain appropriate plugs or caps before detaching hose end fittings, so that ports can be immediately covered to exclude dirt.
3. Clean hose externally and blow through with airline. Examine carefully for cracks, separation of plies, security of end fittings and external damage. Reject any hose found faulty.
4. When refitting hose, ensure that no unnecessary bends are introduced, and that hose is not twisted before or during tightening of union nuts.
5. Containers for hydraulic fluid must be kept absolutely clean.
6. Do not store brake fluid in an unsealed container. It will absorb water, and fluid in this condition would be dangerous to use due to a lowering of its boiling point.
7. Do not allow brake fluid to be contaminated with mineral oil, or use a container which has previously contained mineral oil.
8. Do not re-use brake fluid bled from system.
9. Always use clean brake fluid to clean hydraulic components.
10. Fit a cap to seal a hydraulic union and a plug to its socket after removal to prevent ingress of dirt.
11. Absolute cleanliness must be observed with hydraulic components at all times.
12. After any work on hydraulic systems, inspect carefully for leaks underneath the vehicle while a second operator applies maximum pressure to the brakes (engine running) and operates the steering.

FUEL SYSTEM HOSES



CAUTION: All fuel hoses are made up of two laminations, an armoured rubber outer sleeve and an inner viton core. If any of the fuel system hoses have been disconnected, it is imperative that the internal bore is inspected to ensure that the viton lining has not become separated from the armoured outer sleeve. A new hose must be fitted if separation is evident.

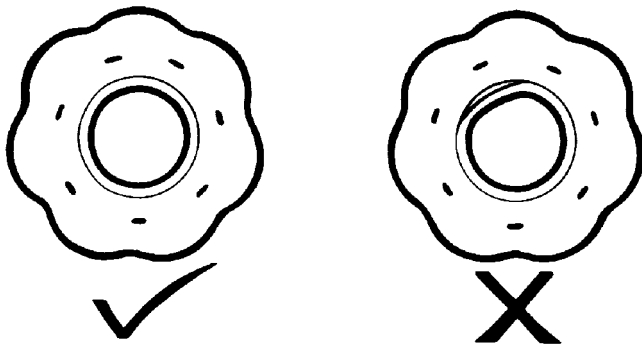

RR2302M

METRIC NUT IDENTIFICATION

1. A nut with an ISO metric thread is marked on one face or on one of the flats of the hexagon with the strength grade symbol 8, 12 or 14. Some nuts with a strength 4, 5 or 6 are also marked and some have the metric symbol M on the flat opposite the strength grade marking.
2. A clock face system is used as an alternative method of indicating the strength grade. The external chamfers or a face of the nut is marked in a position relative to the appropriate hour mark on a clock face to indicate the strength grade.
3. A dot is used to locate the 12 o'clock position and a dash to indicate the strength grade. If the grade is above 12, two dots identify the 12 O'clock position.



1

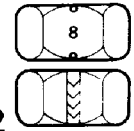

2

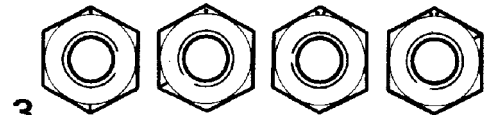

3

ST1036M

METRIC BOLT IDENTIFICATION

1. An ISO metric bolt or screw, made of steel and larger than 6 mm in diameter can be identified by either of the symbols ISO M or M embossed or indented on top of the head.
2. In addition to marks to identify the manufacture, the head is also marked with symbols to indicate the strength grade, e.g. 8.8, 12.9 or 14.9, where the first figure gives the minimum tensile strength of the bolt material in tens of kgf/mm².
3. Zinc plated ISO metric bolts and nuts are chromate passivated, a gold-bronze colour.

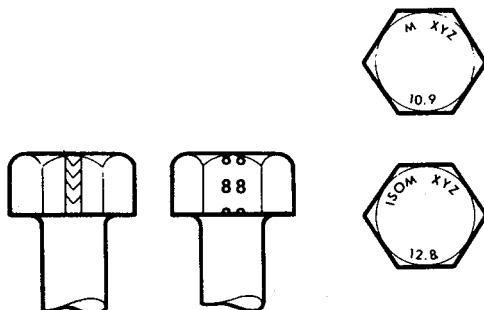

ST1035M

KEYS AND KEYWAYS

1. Remove burrs from edges of keyways with a fine file and clean thoroughly before attempting to refit key.
2. Clean and inspect key closely; keys are suitable for refitting only if indistinguishable from new, as any indentation may indicate the onset of wear.

TAB WASHERS

1. Fit new washers in all places where they are used. Always fit a new tab washer.
2. Ensure that the new tab washer is of the same design as that replaced.

COTTER PINS

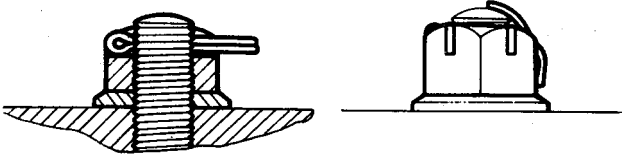

ST1030M

1. Fit new cotter pins throughout when replacing any unit.
2. Always fit cotter pins where cotter pins were originally used. Do not substitute spring washers: there is always a good reason for the use of a cotter pin.
3. All cotter pins should be fitted as shown unless otherwise stated.

NUTS

1. When tightening a slotted or castellated nut never loosen it to insert cotter pin or locking wire except in those recommended cases where this forms part of an adjustment. If difficulty is experienced, alternative washers or nuts should be selected, or washer thickness reduced.
2. Where self-locking nuts have been removed it is advisable to replace them with new ones of the same type.



NOTE: Where bearing pre-load is involved nuts should be tightened in accordance with special instructions.

LOCKING WIRE

1. Fit new locking wire of the correct type for all assemblies incorporating it.
2. Arrange wire so that its tension tends to tighten the bolt heads, or nuts, to which it is fitted.

SCREW THREADS

1. Both UNF and Metric threads to ISO standards are used. See below for thread identification.
2. Damaged threads must always be discarded. Cleaning up threads with a die or tap impairs the strength and closeness of fit of the threads and is not recommended.
3. Always ensure that replacement bolts are at least equal in strength to those replaced.
4. Do not allow oil, grease or jointing compound to enter blind threaded holes. The hydraulic action on screwing in the bolt or stud could split the housing.
5. Always tighten a nut or bolt to the recommended torque value. Damaged or corroded threads can affect the torque reading.
6. To check or re-tighten a bolt or screw to a specified torque value first loosen a quarter of a turn, then re-tighten to the correct value.
7. Oil thread lightly before tightening to ensure a free running thread, except in the case of threads treated with sealant/lubricant, and self-locking nuts.

UNIFIED THREAD IDENTIFICATION

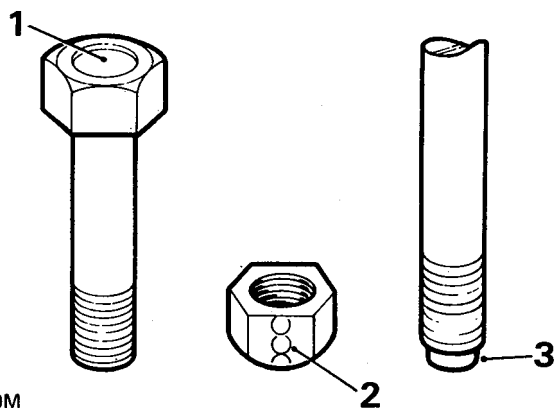

ST1039M

1. Bolts

A circular recess is stamped in the upper surface of the bolt head.

2. Nuts

A continuous line of circles is indented on one of the flats of the hexagon, parallel to the axis of the nut.

3. Studs, Brake Rods, etc.

The component is reduced to the core diameter for a short length at its extremity.



RECOMMENDED LUBRICANTS AND FLUIDS

COMPONENT	SPECIFICATION	VISCOSITY	AMBIENT TEMPERATURE °C										
			-30	-20	-10	0	10	20	30	40	50		
Engine V8i	Use oils to API service level SG, SH or RES.22.OL.G4 or ACEA A2:96	5W/20	█										
		5W/30 5W/40	█	█	█	█	█	█	█	█	█	█	█
		10W/30			█	█	█	█	█	█	█	█	█
		10W/40 10W/50				█	█	█	█	█	█	█	█
		15W/40 15W/50					█	█	█	█	█	█	█
		20W/40 20W/50						█	█	█	█	█	█
Automatic gearbox	ATF Dexron IID		█	█	█	█	█	█	█	█	█	█	
Final drive units Swivel pin housings*	API or GL5 MIL - L - 2105 or MIL - L - 2105B, C or D	90 EP			█	█	█	█	█	█	█	█	
		80W EP				█	█	█	█	█	█	█	
LT 230 transfer gearbox	API GL4 or GL5 MIL - L - 2105 or MIL - L - 2105B	90 EP	█	█	█	█	█	█	█	█	█	█	
Power steering	ATF Dexron IID		█	█	█	█	█	█	█	█	█	█	
Brake reservoir	Brake fluid must have a minimum boiling point of 260°C (500fF) and comply with FMVSS/116/DOT 4		█	█	█	█	█	█	█	█	█	█	
Lubrication nipples (hubs, ball joints, etc.)	NLGI-2 multipurpose lithium based grease		█	█	█	█	█	█	█	█	█	█	

* Swivel pin housings with filler, level and drain plugs.

See table on page 2 for remaining vehicle components

Swivel pin housings **	Molytex EP 00 GREASE to specification XP153
Propeller shaft Front and Rear Lubrication nipples (hubs, ball joints etc.) Seat slides Door lock striker	NLGI - 2 Multi-purpose Lithium based GREASE
Brake reservoir	Brake fluids having a minimum boiling point of 260°C (500°F) and complying with FMVSS 116 DOT4
Engine coolant V8i (aluminium)	Use an ethylene glycol based anti-freeze (containing no methanol) with non-phosphate corrosion inhibitors suitable for use in aluminium engines to ensure the protection of the cooling system against frost and corrosion in all seasons. Use one part anti-freeze to one part water for protection down to -36°C (-33°F). IMPORTANT: Coolant solution must not fall below proportions one part anti-freeze to three parts water, i.e. minimum 25% anti-freeze in coolant otherwise damage to engine is liable to occur. Or a maximum of 60%.
Battery lugs, Earthing surfaces where paint has been removed	Petroleum jelly. NOTE: Do not use Silicone Grease
Air Conditioning System Refrigerant	Use only refrigerant R134a
Compressor Oil	Nippon Denso ND-OIL8 Unipart ND-OIL8
Speed sensor bush-rear	Silicone grease: Staborags NBU - Wabco 830 502,0634 Wacker chemie 704 - Wabco 830 502,0164 Kluber GL301

** Swivel pin housings having a filler plug only.

LUBRICATION PRACTICE

Use a high quality oil of the correct viscosity range and service classification in the engine during maintenance and when topping up. The use of oil not to the correct specification can lead to high oil and fuel consumption and ultimately to damaged components.

Oil to the correct specification contains additives which disperse the corrosive acids formed by combustion and prevent the formation of sludge which can block the oilways. Additional oil additives should not be used. Always adhere to the recommended servicing intervals.



WARNING: Many liquids and other substances used in motor vehicles are poisonous. They must not be consumed and must be kept away from open wounds. These substances, among others, include anti-freeze windscreen washer additives, lubricants and various adhesives.



CAPACITIES

The following capacity figures are approximate and are provided as a guide only.

Capacities (approx.)	Litres	US unit
Fuel tank usable fuel	59	15.6 gall
Engine sump oil - V8i	6.0	6.5 quarts
-Extra after fitting new filter	0,6	1.2 pt
Automatic gearbox *	9,1	9.6 quarts
Transfer gearbox oil	2,3	4.8 pt
Front differential	1,7	3.6 pt
Rear differential	2.3	4.8 pt
Power steering box and reservoir	2,9	6.0 pt
Swivel pin housing oil / grease (each) **	0,35	0.75 pt
Cooling system	12.8	13.5 quarts
Washer bottle	3,0	6.0 pt



NOTE: All levels must be checked by dipstick or level plugs as applicable.

* When draining fluid from the ZF automatic gearbox, fluid will remain in the torque converter, refill to high level on dipstick only.

** Swivel pin housings with a filler plug only must be filled with GREASE.

ANTI-FREEZE

ENGINE TYPE	MIXTURE STRENGTH	PERCENTAGE CONCENTRATION	PROTECTION LOWER TEMPERATURE LIMIT
V8i Engine	One part anti-freeze One part water	50%	
Complete protection Vehicle may be driven away immediately from cold			- 33°F - 36°C
Safe limit protection Coolant in mushy state. Engine may be started and driven away after warm-up period			- 41°C - 42°F
Lower protection Prevents frost damage to cylinder head, block and radiator. Thaw out before starting engine			- 47°C - 53°F



CAUTION: Anti-freeze content must never be allowed to fall below 25% otherwise damage to the engine is liable to occur. Also, anti-freeze content should not exceed 60% as this will greatly reduce the cooling effect of the coolant.

RECOMMENDED FUEL**Petrol engines**

- with catalytic converter UNLEADED ONLY USA 90 CLC or 92 AKI

Catalyst vehicles

Vehicles equipped with catalytic converter are designed to use ONLY unleaded fuel. Unleaded fuel must be used for the emission control system to operate properly. Its use will also reduce spark plug fouling, exhaust system corrosion and engine oil deterioration.

Regulations require that pumps delivering unleaded fuel be labelled **UNLEADED**. Only these pumps have nozzles which fit the filler neck of the vehicle fuel tank.

Using fuel that contains lead will result in damage to the emission control system and could result in loss of warranty coverage. The effectiveness of the catalysts in the catalytic converters will be seriously impaired if leaded fuel is used. The vehicle is equipped with an electronic fuel injection system, which includes four oxygen sensors. Leaded fuel will damage the sensors, and will deteriorate the emission control system.



SERVICE SCHEDULE

This section gives information on the range of service procedures.

Where required, instructions are given for carrying out each service procedure, or a cross reference is given, where the procedure can be found in this manual.

Service Schedule sheets are published separately to reflect the maintenance needs and intervals for each vehicle variant and model year. The procedures given must be used in conjunction with the Service Schedule sheets.

VEHICLE INTERIOR

CHECK SEATS & BELTS

Check condition and security of seats, seat belt mountings, seat belts, buckles and operation of inertia seat belts.

Lubricate seat tilt pivots.

CHECK OPERATION OF FOOT BRAKE

If pedal feels 'spongy' bleed system. ***See BRAKES, Repair, Brake System Bleed***

Check all hoses and pipes for security, fractures and leaks. Fit new hoses and pipes as necessary.

CHECK OPERATION OF LAMPS

Check operation of all lamps, horns and warning indicators.

CHECK OPERATION OF WIPERS

Check operation of front/rear screen wipers and washers and condition of wiper blades.

CLEAN BATTERY TERMINALS

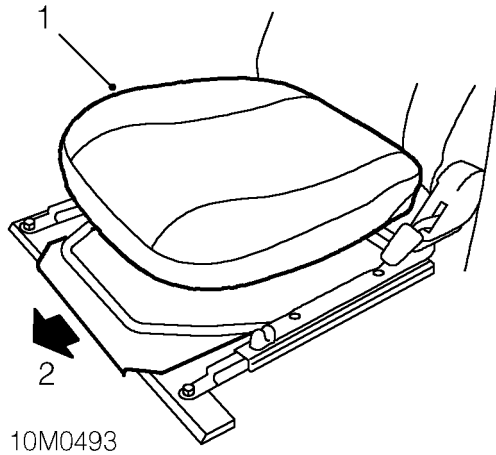

1. Remove LH front seat cushion.
2. Release retaining clip and remove battery access cover.

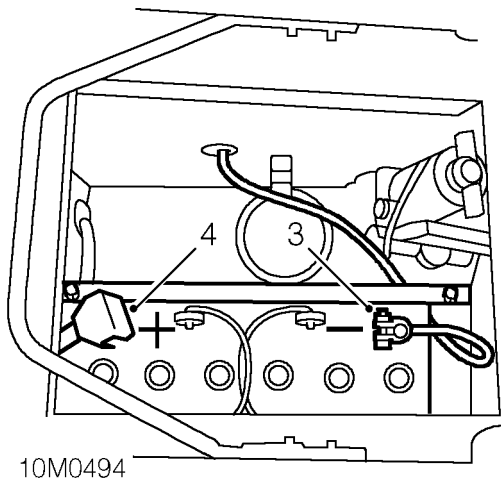

3. Disconnect both battery leads, negative '-' first. Clean off corrosion and neutralize. Smear terminals with petroleum jelly.
4. Reconnect battery leads, positive first, when maintenance operations have been completed.
5. Fit battery access cover and LH front seat cushion.

A low maintenance battery is fitted as original equipment. Dependent upon climatic conditions electrolyte levels should be checked as follows:
Temperate climates every 3 years.
Hot climates every year.

CHECK/ADJUST OPERATION OF PARK BRAKE

Park brake check

1. Check park brake is fully operational on third notch of ratchet. Readjust if necessary.

Park brake adjust

1. Select 'P' in main gearbox and chock road wheels.
2. Raise one rear wheel clear of ground and support securely with axle stand.
3. Release park brake lever.

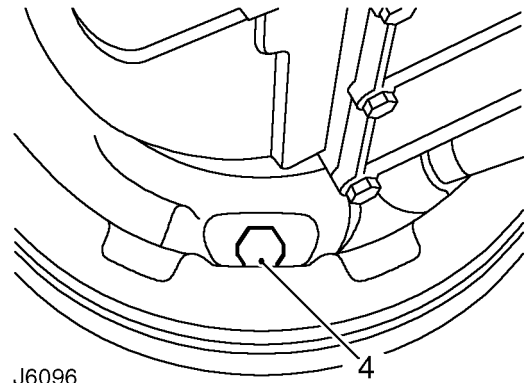

4. Underneath vehicle, rotate brake adjuster clockwise to 25 Nm, 18 lbf ft to fully expanded shoes against drum.
5. Back off adjuster by 1... turns, check that drum is free to rotate.
6. Adjust park brake cable locknuts to give pawl 2 notches free movement on ratchet before being fully operational on third notch of ratchet.



CAUTION: Cable adjustment must ONLY be used for initial setting and to compensate for cable stretch. It MUST NOT be used to take up brake shoe wear, which MUST be adjusted at brake drum.

7. Operate parking brake to settle shoes. Recheck park brake is fully operational on third notch of ratchet. Readjust if necessary.
8. Remove axle stand and wheel chocks.



VEHICLE EXTERIOR

CHECK/ADJUST HEADLAMP ALIGNMENT

Check/adjust headlamp and auxiliary alignment.

REMOVE WHEELS, CHECK TYRES

Check tyres (including spare) for compliance with manufacturers' specification.

Check visually for cuts, lumps, bulges, uneven tread wear and tread depth. Check road wheels for damage.

Check/adjust tyre pressures.

INSPECT BRAKE PADS FOR WEAR, CALIPERS FOR LEAKS AND CONDITION

Check thickness of brake pads, fit new pads if minimum thickness is less than 3,0mm, 0.12 in. Check brake pads for oil contamination. If new brake pads required. **See BRAKES, Repair, Front Brake Pads** or. **See BRAKES, Repair, Rear Brake Pads**



WARNING: When renewing brake pads, it is essential that only genuine components with correct grade of lining are used.

Always fit new pads as complete axle sets, NEVER individually or as a single wheel set. Serious consequences could result from out of balance braking due to mixing of linings.

Refit road wheels

Fit road wheels in original hub position. Secure in position with wheel nuts, do not fully tighten wheel nuts at this stage, lower vehicle and finally tighten wheel nuts to correct torque.

Alloy wheels: **130 Nm, 95 lbf ft.**

CHECK FRONT WHEEL ALIGNMENT

Use recognised wheel alignment equipment to perform this check and adjustment. **See STEERING, Adjustment, Front Wheel Alignment**

LUBRICATE ALL HINGES, DOOR CHECK MECHANISMS, BONNET [HOOD] CATCHES AND FUEL FILLER FLAP

CHECK OPERATION OF ALL DOOR, BONNET [HOOD] AND TAILDOOR LOCKS

CHECK/TIGHTEN TOWING BRACKET FITTINGS

UNDER BONNET [HOOD] MAINTENANCE

CHECK COOLING/HEATER SYSTEMS

Check cooling/heater systems for leaks and hoses for security and condition.

Cooling system hoses should be changed at first signs of deterioration.

CHECK CONDITION OF ENGINE MOUNTING RUBBERS

CHECK BRAKE SERVO HOSE FOR SECURITY AND CONDITION

CHECK FUEL EVAPORATIVE LOSS CONTROL SYSTEM FOR LEAKS

CHECK FUEL FILLER CAP SEAL FOR LEAKS

CHECK IGNITION WIRING

Check H.T. leads for fraying, chafing and deterioration. Ensure H.T. leads are correctly clipped in place.

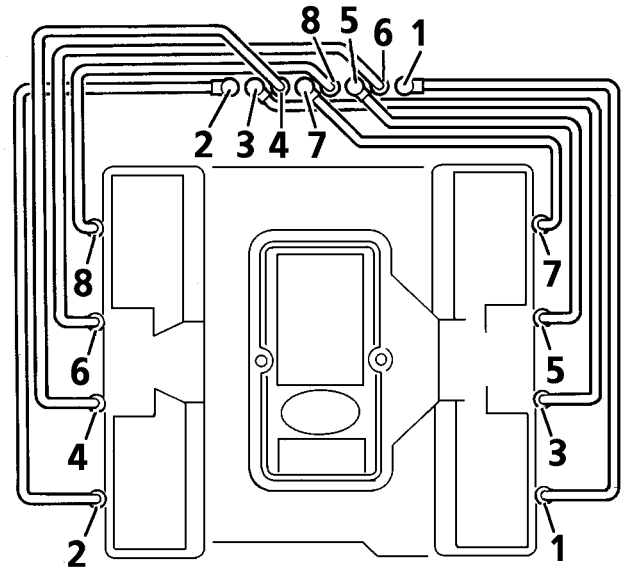

10M0428



RENEW SPARK PLUGS - V8i

Clean, adjust and renew

1. Take great care when fitting spark plugs not to cross-thread plug, otherwise costly damage to cylinder head will result.
2. Clean or replace spark plugs as applicable.
3. It is essential that correct type of spark plugs are fitted.
4. Incorrect grade of plugs may lead to piston overheating and engine failure.

Remove

5. Disconnect battery negative lead. Disconnect H.T. leads from spark plugs.
6. Remove plugs and washers.

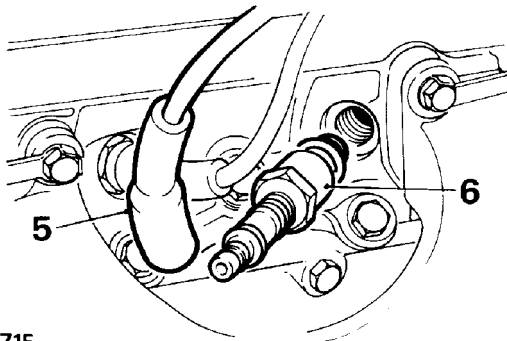

RR2171E

Refit

7. Inspect spark plugs, renew as necessary.
8. Set plug gaps.



CAUTION: Use correct type and grade of plug.

9. Apply anti-seize to plug threads. Fit spark plugs. Tighten to **20Nm, 15 lbf ft.**
10. Connect and route spark plug leads correctly. Failure to route H.T. leads correctly may result in cross-firing between two closely fitted leads which are consecutive in firing order.



CAUTION: When pushing leads onto plugs, ensure that shrouds are firmly seated.

CLEAN PLENUM CHAMBER VENTILATION PASSAGEWAY - V8i



CAUTION: Care must be taken to prevent debris from passageway passing beyond throttle butterfly disc.



WARNING: Safety glasses must be worn when performing this operation. Ensure that debris is not blown into atmosphere which could be harmful to other persons closeby.

1. Disconnect battery negative lead.
2. Release hose clamp and remove hose from plenum chamber inlet.
3. Remove crankcase ventilation hose from side of plenum chamber.
4. Insert a piece of lint free cloth down throttle butterfly bore to prevent debris passing throttle butterfly.
5. Place a cloth over tube protruding from side of plenum from which ventilation hose was removed to prevent debris from passageway being blown into atmosphere.

6. Use a compressed air line with a slim bent nozzle to enable passageway to be cleaned out from within throttle butterfly bore.
7. Any remaining matter can be dislodged using soft bent wire or pipe cleaner. Finally blow out passageway again to remove remaining debris.
8. Remove small 'T' piece between crankcase ventilation hoses and check it is free from blockages, clean as necessary.
9. Refit 'T' piece and hoses, tighten hose clamps securely.

RENEW AIR CLEANER ELEMENT - V8i

To renew air cleaner element - V8i
See FUEL SYSTEM, Repair, Air Cleaner

RENEW CHARCOAL CANISTER AND PURGE CONTROL VALVE - V8i

Renew charcoal canister and purge control valve.
See EMISSION CONTROL, Repair, EVAP canister and purge control valve

CHECK AUXILIARY DRIVE BELT - V8i

1. Check condition of drive belt, renew a belt that shows signs of wear, splitting or oil contamination.
2. Check belt length indicator, **belt MUST be renewed before indicator reaches RH end of slot.**

RENEW AUXILIARY DRIVE BELT - V8i

Renew drive belt. *See ELECTRICAL, Repair, Auxiliary drive Belt*

CHECK/TOP-UP AUTOMATIC TRANSMISSION FLUID LEVEL



NOTE: Transmission fluid level is checked when fluid is cold with engine idling in 'N' (neutral).

1. Ensure vehicle is on level ground.
2. Check fluid level registers between the 2 level marks on dipstick.
3. Top-up to high mark on dipstick using the correct grade of transmission fluid. *See LUBRICANTS, FLUIDS AND CAPACITIES, Information, recommended lubricants and fluids*



CHECK/TOP-UP COOLING SYSTEM

To prevent corrosion of aluminium alloy engine parts it is imperative that cooling system is filled with a solution of water and phosphate free anti-freeze, at all times. **Never fill or Top-up with plain water.**



WARNING: Do not remove filler cap when engine is hot because cooling system is pressurised and personal scalding could result.

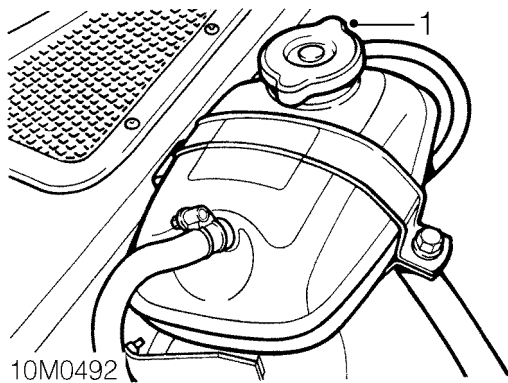

1. First turn filler cap slowly counter-clockwise to its stop, pause and allow all pressure to escape. Press down and continue to turn until cap is removed.
2. When engine is cold, expansion tank should be approximately half full with coolant
3. If necessary, Top-up cooling system with premixed coolant. Use soft water whenever possible, if local water supply is hard, rainwater should be used.
4. When replacing filler cap it is important that it is tightened down fully. Failure to tighten filler cap properly may result in water loss, with possible damage to engine

The cooling system should be drained and flushed at 2 year intervals or at onset of second winter. Refer to Coolant Requirements. **See COOLING SYSTEM, Adjustment, Coolant Requirements**

CHECK/TOP-UP POWER STEERING FLUID RESERVOIR

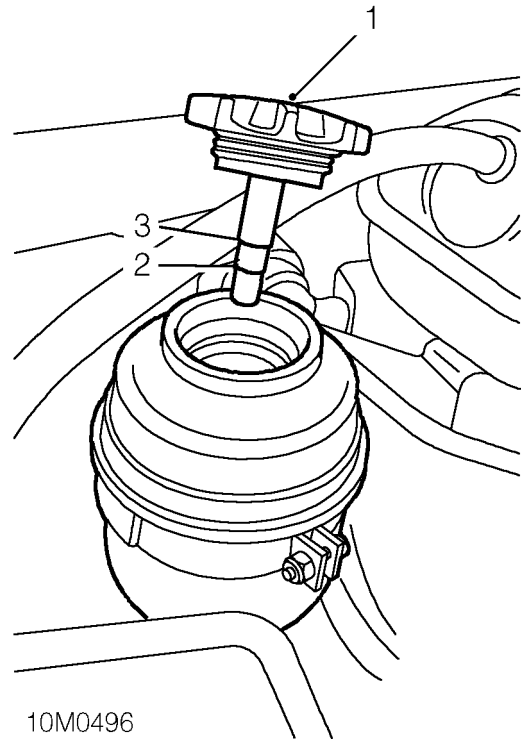

1. Clean area of fluid reservoir cap and remove cap.
2. Check that fluid level is not below lower mark on dipstick.
3. Top-up to high mark on dipstick using transmission fluid. **See LUBRICANTS, FLUIDS AND CAPACITIES, Information, recommended lubricants and fluids**

CHECK/ TOP-UP BRAKE FLUID RESERVOIR



CAUTION: Brake fluid can damage paintwork. If spillage occurs, wash affected area **IMMEDIATELY** with a large quantity of water.

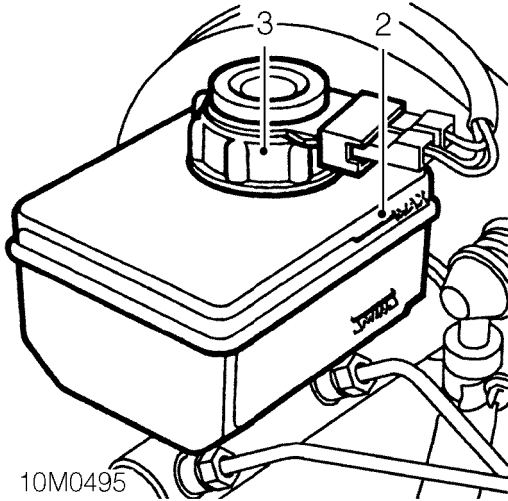

1. Clean area of filler cap and side of reservoir.
2. Check fluid level in reservoir by observing level through translucent side. Level must be above 'MIN' mark.



CAUTION: If level is below 'MIN' mark, check braking system for possibility of fluid leakage.

3. Remove filler cap and top-up to 'MAX' mark with NEW brake fluid of the correct specification from a sealed container. **See LUBRICANTS, FLUIDS AND CAPACITIES, Information, recommended lubricants and fluids**
4. Refit filler cap.

CHECK/TOP-UP WASHER RESERVOIR

Top-up washer reservoir to within 25 mm, 1.0 in of filler neck. Use a screen washer solvent/anti-freeze solution to assist removing mud, flies and road film and protect against freezing.

CHECK/ADJUST STEERING BOX

1. Check steering box for fluid leaks.
2. Check that there is no backlash in steering box in straight ahead position. Adjust steering box if necessary. **See STEERING, Adjustment, Power Steering Box - adjust**



UNDER VEHICLE MAINTENANCE

Vehicles operating under severe conditions of dust, sand, mud or water should have oils changed and lubrication carried out at more frequent intervals than is recommended in maintenance schedules.

RENEW ENGINE OIL AND FILTER - V8i

1. Ensure vehicle is level. If necessary, run engine to warm oil.
2. Disconnect battery. See Clean battery terminals.
3. Place drain tray under drain plug.
4. Remove engine oil dipstick.

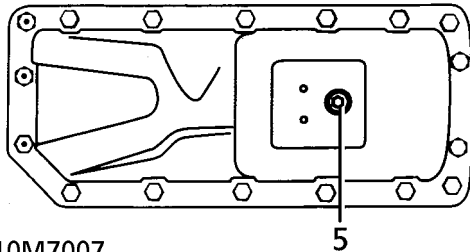

10M7007

5. Remove sump drain plug. Allow oil to drain completely.
6. Fit NEW copper washer and refit drain plug. **43 Nm, 32 lbf ft.**

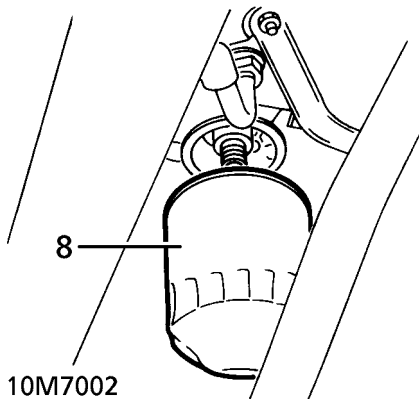

10M7002

7. Place drain tray under filter.
8. Unscrew oil filter counter-clockwise.

9. Clean filter adaptor face. Coat sealing ring on NEW filter with clean engine oil. Screw filter on until sealing ring contacts sealing face (finger tight), then tighten a further half turn by hand only. **DO NOT** overtighten.
10. Remove engine oil filler cap. Clean inside and outside of cap.
11. Pour in correct quantity of NEW oil to 'FULL' mark on dipstick. **See LUBRICANTS, FLUIDS AND CAPACITIES, Information, recommended lubricants and fluids**
12. Reconnect battery, run engine and check for oil leaks from oil filter.
13. Stop engine, allow oil to return to sump for a few minutes, then recheck oil level and top-up if necessary.



NOTE: Oil can symbol on dipstick must be correct way up when viewed from LH side of vehicle.

RENEW AUTOMATIC GEARBOX FLUID AND FLUID SCREEN - ZF

1. Ensure vehicle is level. Place drain tray under drain plug.

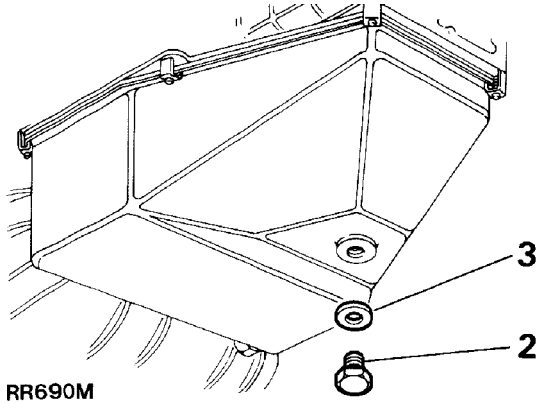

2. Remove gearbox dipstick, located at rear of RH rocker cover, to aid oil drainage. Remove drain plug from bottom of sump and allow fluid to drain completely.
3. Refit plug using a NEW sealing washer. Tighten to **10 Nm, 8 lbf ft.**
4. Remove and replace fluid screen. **See AUTOMATIC GEARBOX, Repair, Fluid Pan Gasket and Screen**

Refill and Check Fluid Level.



NOTE: The fluid level must checked when fluid is **COLD** and engine idling in 'N'.

5. Refill or top-up with correct quantity and grade of fluid. **See LUBRICANTS, FLUIDS AND CAPACITIES, Information, recommended lubricants and fluids**

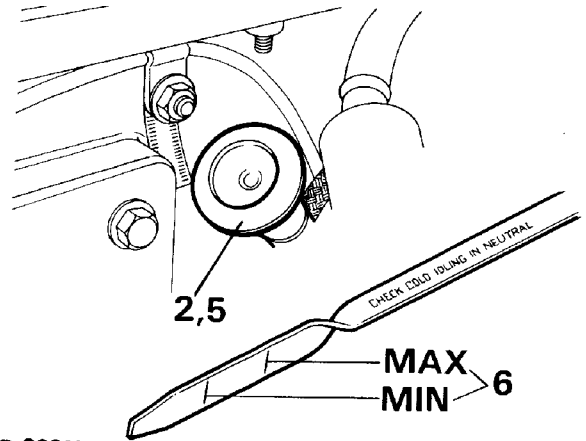

6. With 'P' selected, start and run engine. Apply footbrake, move selector slowly to position '1' then back to 'N'. Check fluid level, this must be between the 2 level marks on dipstick.



CHECK/TOP-UP TRANSFER GEARBOX OIL

1. Ensure vehicle is level.
2. Disconnect battery negative lead.
3. Clean area around filler/level plug.
4. Remove plug and fill gearbox with recommended grade of oil, until oil starts to seep from filler/level hole. **See LUBRICANTS, FLUIDS AND CAPACITIES, Information, recommended lubricants and fluids**
5. Clean any previously applied sealant from filler/level plug.
6. Apply Hylomar sealant to threads of plug and refit plug. Tighten to **30 Nm, 22 lbf ft.**
7. Wipe away any surplus oil.
8. Reconnect battery negative lead.

RENEW TRANSFER GEARBOX OIL

1. Ensure vehicle is level.
2. Disconnect battery negative lead.
3. Clean area around filler/level and drain plugs.



WARNING: When draining gearbox care should be taken to ensure that oil is not hot as personal scalding could result.

4. Place a suitable container under transfer gearbox.

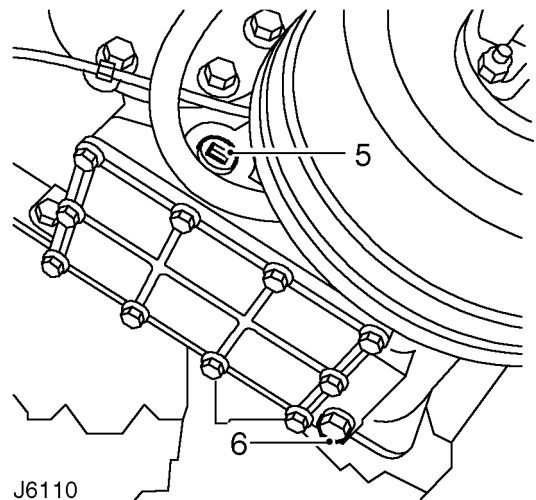

5. Remove filler/level plug to vent gearbox and assist draining.
6. Remove drain plug and allow oil to drain.
7. Thoroughly clean drain plug threads prior to applying fresh 'Hylomar' sealant. Fit plug Tighten to **30 Nm, 22 lbf ft.**
8. Fill gearbox with correct quantity and grade of oil until oil seeps from filler level hole. Wipe away any surplus oil. **See LUBRICANTS, FLUIDS AND CAPACITIES, Information, Recommended lubricants and fluids**
9. Thoroughly clean filler/level plug threads prior to applying fresh 'Hylomar' sealant. Fit plug Tighten to **30 Nm, 22 lbf ft.**
10. Reconnect battery negative lead.

CHECK/TOP-UP FRONT AND REAR AXLE OIL

1. Ensure vehicle is level.
2. Using a 13mm, 0.5 in square drive wrench, remove filler/level plug from axle.
3. If necessary inject oil of recommended grade until it reaches level hole. **See LUBRICANTS, FLUIDS AND CAPACITIES, Information, recommended lubricants and fluids**
4. Clean and refit filler/level plug and wipe away surplus oil.

CHECK/TOP-UP SWIVEL PIN HOUSING OIL



CAUTION: Housings with filler plug only are filled with grease which does not require top-up or renewing.

1. Site vehicle on lift or level ground. Clean area of filler/level plug.
2. Remove filler/level plug and inject recommended grade of oil until it seeps from level hole.
3. Refit filler/level plug, wipe away any surplus oil.

RENEW FRONT AND REAR AXLE OIL

1. Site vehicle on lift or level ground. Place container under axle to be drained.

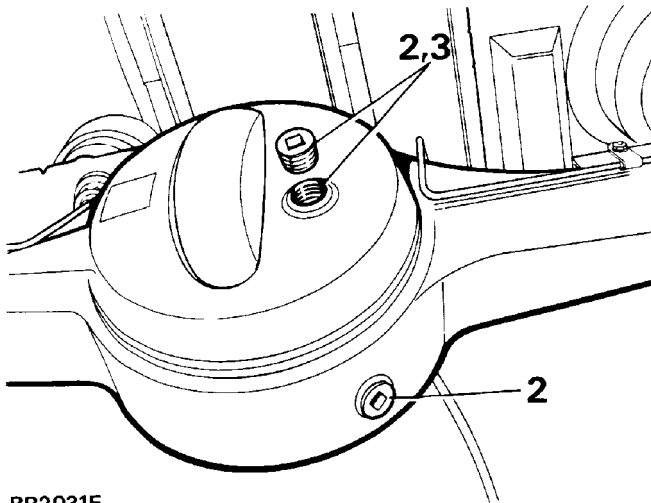

RR2031E

2. Using a 13mm, 0.5 in square drive wrench, remove drain and filler/level plugs from axle. Allow oil to drain completely. Clean and refit drain plug.
3. Inject new oil of recommended make and grade until it reaches level hole. **See LUBRICANTS, FLUIDS AND CAPACITIES, Information, recommended lubricants and fluids**
4. Clean and refit filler/level plug and wipe away surplus oil.

RENEW SWIVEL PIN HOUSING OIL

1. Site vehicle on lift or level ground. Place container under swivel to be drained.

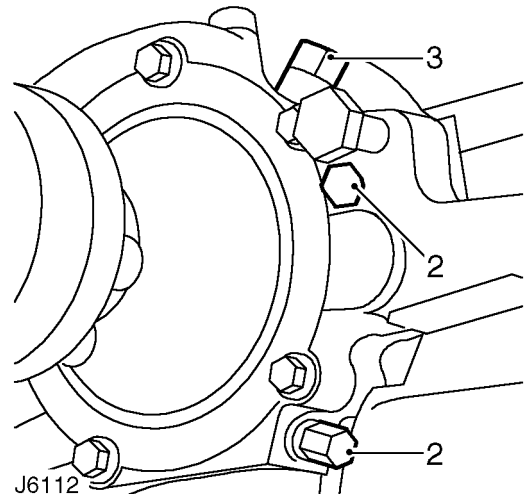

J6112

2. Remove drain and level plugs, allow oil to drain completely, clean and refit drain plug.
3. Remove filler plug and inject recommended grade of oil it reaches level hole.
4. Clean and refit level and filler plugs, wipe away any surplus oil.



NOTE: On later vehicles, the level and drain plugs have been deleted. The swivel pin housing is filled with grease for life service and maintenance is not required.



LUBRICATE PROPELLER SHAFT SLIDING AND UNIVERSAL JOINTS

1. Clean all grease nipples on front and rear propeller shafts.

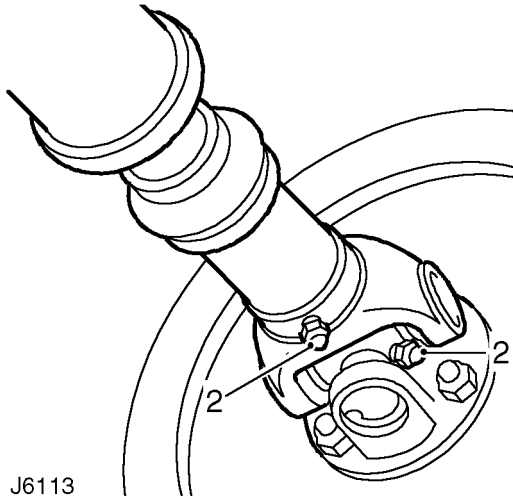

J6113

2. Using a low pressure hand grease gun, apply recommended grease, to grease nipples at front and rear propeller shaft universal and sliding joints.

CHECK VISUALLY BRAKE, FUEL PIPES/UNIONS FOR CHAFING LEAKS AND CORROSION

CHECK EXHAUST SYSTEM FOR LEAKS, SECURITY AND DAMAGE

CHECK FOR FLUID LEAKS FROM POWER STEERING AND SUSPENSION SYSTEMS, HYDRAULIC PIPES AND UNIONS FOR CHAFING AND CORROSION

CHECK/TIGHTEN STEERING UNIT AND STEERING ROD BALL JOINT FIXINGS, CHECK CONDITION OF OF BALL JOINTS AND DUST COVERS

Ball joints are lubricated for their normal life during manufacture and require no further lubrication. This applies ONLY if rubber boot has not been dislodged or damaged. Joints should be checked at specified mileage intervals but more frequently if vehicle is used under arduous conditions.

1. Check for wear in joints by moving ball joint up and down vigorously. If free movement is apparent fit a new joint assembly.

CHECK/TIGHTEN FRONT AND REAR AXLE SUSPENSION LINK FIXINGS, CHECK CONDITION OF MOUNTING RUBBERS.

CHECK/TIGHTEN TOWING BRACKET FIXINGS.

RENEW FUEL FILTER



WARNING: Ensure that fuel handling precautions given in Section 01 - Introduction are strictly adhered to when carrying out following instructions. See *INTRODUCTION, Information, Fuel Handling Precautions*



WARNING: The spilling of fuel is unavoidable during this operation. Ensure that all necessary precautions are taken to prevent fire and explosion.

The fuel line filter is located on RH chassis side member forward of the rear wheel arch.

1. Disconnect battery negative lead.

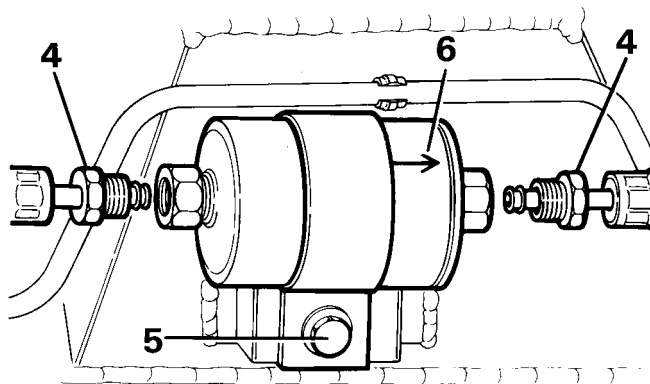

RR2966E

2. Thoroughly clean area around hose connections.
3. Position cloth around relevant union on fuel filter to protect against fuel spray as fuel line pressure is released. See *FUEL SYSTEM, Repair, Fuel filter*
4. Loosen 2 fuel unions and disconnect hoses from filter canister.
5. Loosen bolt securing bracket to chassis side member and remove filter.

Fit new filter

6. Fit a new filter and tighten bracket bolt. Ensure direction of flow ARROW on canister faces forward.
7. Fit inlet and outlet hoses. **30 Nm, 22 lbf ft.**

8. Reconnect battery negative lead.
9. Start engine and inspect hose connections for fuel leaks.

RENEW HEATED OXYGEN SENSORS (HO2S)

See *FUEL SYSTEM, Repair, Heated Oxygen Sensor (HO2S) - Front* and

See *FUEL SYSTEM, Repair, Heated Oxygen Sensor (HO2S) - Rear*

RENEW CATALYTIC CONVERTERS

See *EMISSION CONTROL, Repair, front pipe / catalytic converter*

REPORT ANY UNUSUAL FEATURES OF VEHICLE CONDITION AND ADDITIONAL WORK REQUIRED



CARRY OUT ROAD OR ROLLER TEST



WARNING: Two wheel roller tests must be restricted to 8 mph, 5km/hour. Do not engage the differential lock or the vehicle will drive off the test rig because the vehicle is in permanent four wheel drive.

For details of dynamometer testing. **See INTRODUCTION, Information, Dynamometer Testing**

Check following items:

1. Inhibitor switch only operates in 'P' and 'N'.
2. Engine for excessive noise.
3. Automatic gear selection/shift speeds.
4. Gear selection/noise - high/low range.
5. Steering for abnormal noise/effort.
6. Steering for free play.
7. All instruments, gauges and warning indicators.
8. Heater and air conditioning systems.
9. Heated rear screen.
10. Shock absorbers - ride irregularities.
11. Foot brake, on emergency stop, pulling to one side, binding, pedal effort.
12. Park brake operation.
13. Seat reclining and latching.
14. Fully extend seat belt, check operation of retraction and latching. Inertia belts lock when snatched or vehicle on slope.
15. Road wheel balance.
16. Transmission for vibrations.
17. Body noises, squeaks and rattles.
18. Excessive exhaust smoke.
19. Engine idle speed.
20. Endorse service record.
21. Report any unusual features of vehicle condition and additional work required.

ENDORSE SERVICE RECORD

RESET EMISSION MAINTENANCE REMINDER - USA

The emission maintenance reminder is designed to activate at 82,500 and 165,000 miles respectively and will illuminate a 'Service Engine' RED warning light in instrument binnacle.

The emission maintenance reminder must be reset after required maintenance has been carried out and a new tamperproof label fitted by a Land Rover of North America dealer. This emission maintenance reminder is part of the Emission Control System

Reset

1. The control unit is located in the passenger footwell.
2. Identify control unit and remove from plug.
3. Remove tamperproof label to reveal access hole for resetting.
4. Place a thin metallic probe into access hole and momentarily electrically short between reset pins inside unit.

RECOMMENDED SERVICE ITEMS

Refer Service Schedule sheets for intervals.

Clean sunroof drain tubes, clean and lubricate guide rails and slides.

Renew the hydraulic brake fluid. **See BRAKES, Repair, Brake System Bleed**

Renew all hydraulic brake fluid, seals, brake servo filter and flexible hoses.

All working surfaces of the master cylinder and caliper cylinders should be examined and renewed where necessary.

Air cleaner - When the vehicle is used in dusty or field conditions or deep wading, frequent attention to the air cleaner may be required.



TORQUE SETTINGS

	Nm	lbf ft
Road wheel nuts	130	95
Spark plugs	20	15
Automatic gearbox drain plug	10	8
Transfer box drain/filler plugs	30	22
Fuel filter hose/pipe unions	30	22
Steering box drop arm nut	175	130
Steering box to chassis	80	60
Steering box tie-rod	80	60
Front radius arm to chassis	200	150
Rear radius arm to axle	175	130
Bottom link to axle/chassis	175	130



CRANKSHAFT REAR OIL SEAL

Service repair no - 12.21.20

Remove

1. Disconnect battery negative lead.
2. Remove drive plate. **See ENGINE 4.0 V8, Repair, Drive Plate**

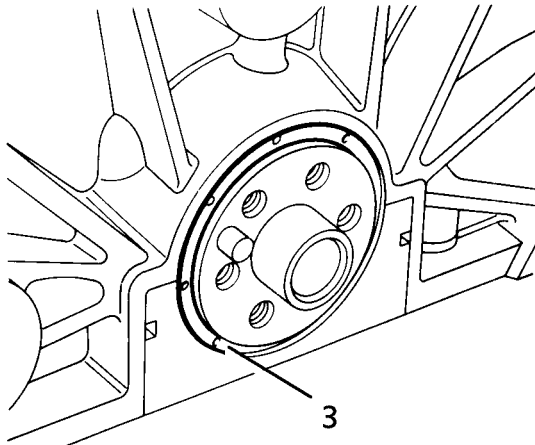

12M7016

3. Remove oil seal from location.



CAUTION: Do not damage seal location or running surface on crankshaft.

Refit

4. Ensure both seal location and running surface on crankshaft are clean.
5. Ensure mating faces of flywheel and crankshaft are clean.
6. Lubricate seal guide **LRT-12-095** with clean engine oil. Position over crankshaft boss.

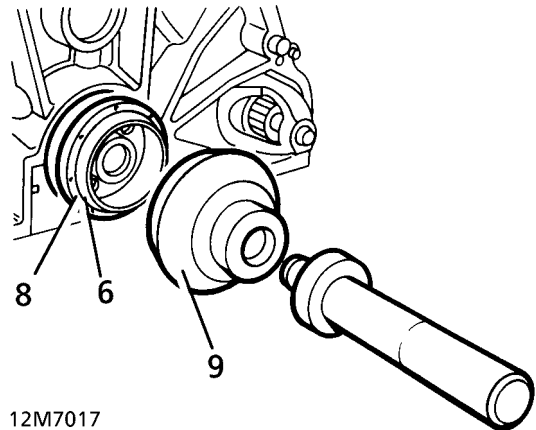

12M7017

7. Lubricate oil seal lip.
8. Position seal squarely. Remove guide.
9. Drift seal into location using **LRT-12-091**.
10. Fit drive plate. **See ENGINE 4.0 V8, Repair, Drive Plate**
11. Reconnect battery negative lead.

DRIVE PLATE

Service repair no - 12.53.13

Remove

1. Remove gearbox and transfer box assembly. **See AUTOMATIC GEARBOX, Repair, gearbox and transfer box assembly**

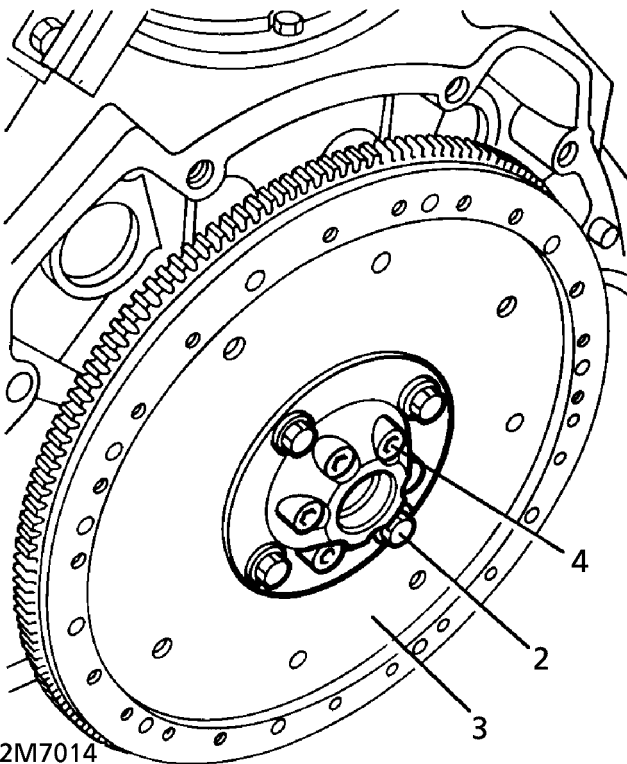

2. Remove 4 clamp ring bolts. Collect clamp ring.
3. Remove flexible drive plate/starter ring gear assembly from hub aligner.
4. Remove 6 screws from hub aligner. Remove hub aligner from crankshaft. Collect shim.
5. Check drive plate for distortion or cracks. Check starter ring gear for chipped or broken teeth. If either component shows signs of damage, fit a new assembly.

Refit

6. Ensure all mating surfaces are clean.
7. Fit shim and hub aligner to crankshaft.
8. Fit hub aligner screws and tighten to **85 Nm, 63 lbf ft.**
9. Fit drive plate and clamp ring.
10. Fit clamp ring bolts and tighten to **45 Nm, 33 lbf ft.**



NOTE: It is only necessary to reshim the drive plate when a new crankshaft or hub aligner is fitted.

11. Fit gearbox and transfer box assembly. **See AUTOMATIC GEARBOX, Repair, gearbox and transfer box assembly**



ROCKER SHAFT RENEW

Service repair no - 12.29.29

1. Remove RH or LH rocker covers. *See ENGINE 4.0 V8, Repair, rocker cover - right hand* or. *See ENGINE 4.0 V8, Repair, rocker cover - left hand*
2. Loosen four rocker shaft fixings.

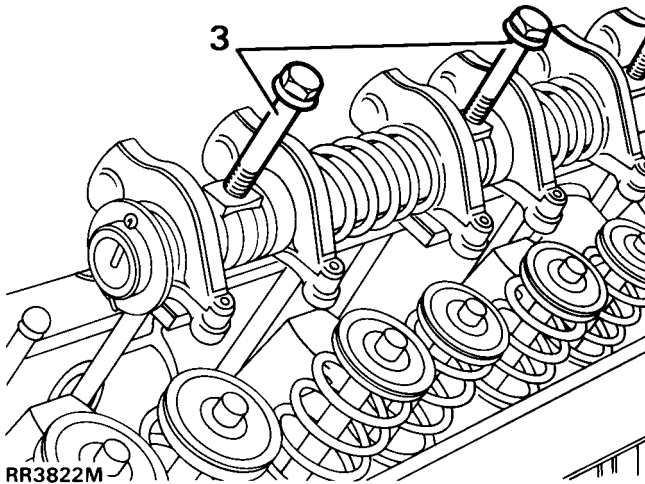

3. Remove rocker shaft assembly.



NOTE: Each rocker shaft is notched at **ONE** end. Notch must be uppermost and towards front of engine on right hand side, towards rear on left hand side.

4. Clean rocker pedestal locations on cylinder head.
5. Fit rocker shaft assembly, locating push rods to rockers.
6. Tighten rocker shaft fixings to **38 Nm, 28 lbf ft.**
7. Fit rocker covers.
8. Fit RH or LH rocker covers. *See ENGINE 4.0 V8, Repair, rocker cover - right hand* or *See ENGINE 4.0 V8, Repair, rocker cover - left hand*

OIL SUMP

Service repair no - 12.60.44

Remove

1. Drain engine oil *See SECTION 10, Maintenance, Under vehicle maintenance*
2. Fit and tighten drain plug to **40 Nm, 30 lbf ft.**
3. Remove bolt securing dipstick tube to rocker cover.
4. Working from the centre outwards, progressively loosen and remove 3 screws and 14 bolts securing sump. Remove sump.
5. Remove all traces of sealant from mating surfaces of sump, cylinder block and timing cover, using a suitable solvent or plastic scraper.
6. Degrease mating surfaces of sump, cylinder block and front cover.

Refit

7. Apply RTV Hylosil White sealant to mating surface of sump.
8. Position sump, tighten bolts finger tight.

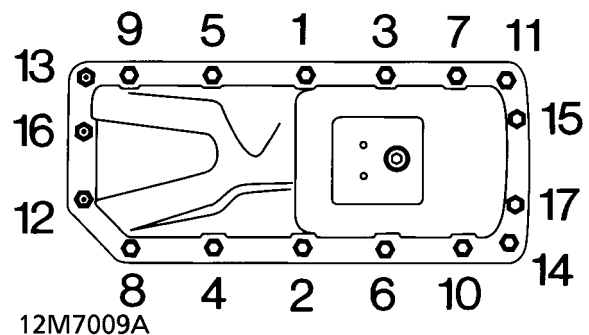

9. Tighten nuts and bolts progressively in sequence shown to **23 Nm, 17 lbf ft.**
10. Fit bolt securing dipstick tube to rocker cover.

ROCKER COVER GASKET - LEFT HAND

Service repair no - 12.29.40

Remove

1. Disconnect battery negative lead.
2. Remove plenum chamber. **See FUEL SYSTEM, Repair, plenum chamber**

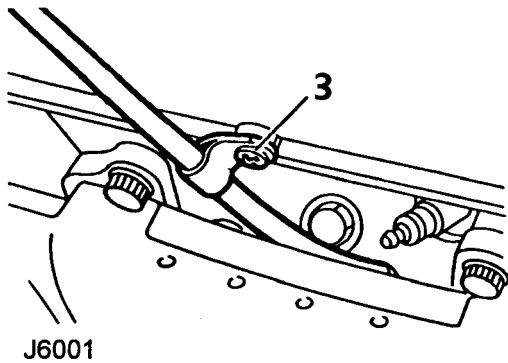

J6001

3. Remove screw securing dipstick tube to rocker cover.

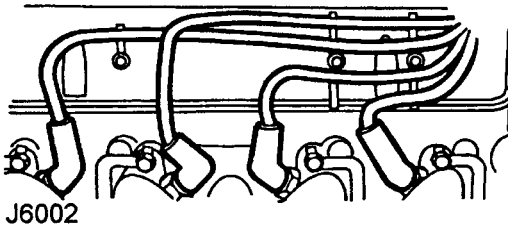

J6002

4. Release 4 spark plug leads from guide clips and disconnect leads from spark plugs.

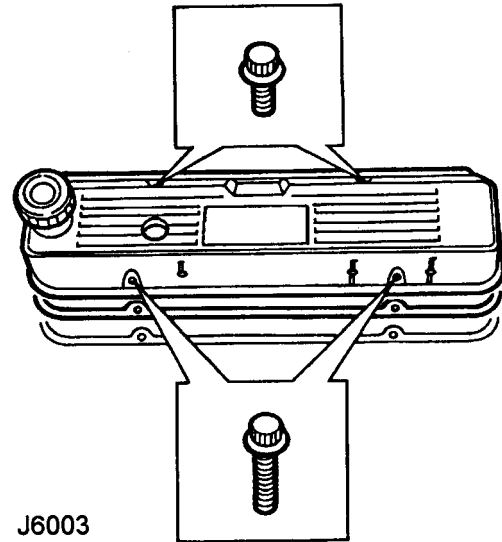

J6003

5. Remove 4 bolts securing rocker cover to cylinder head.
6. Remove rocker cover.
7. Remove and discard rocker cover gasket.

Refit

8. Clean mating faces of rocker cover and cylinder head using Bostick 6001 or equivalent. Allow to dry.
9. Apply a thin coating of impact adhesive (Bostick 1775 or equivalent) to mating faces of rocker cover and gasket. Use a brush to ensure an even film. Allow adhesive to become touch dry.



CAUTION: Gasket fits one way round only. It must be fitted accurately, first time. Subsequent movement will destroy bonding.

bonding.

10. Place one end of gasket into cover recess with edge firmly against recess wall, holding remainder of gasket clear. Work around cover pressing gasket into place ensuring edge firmly contacts recess wall.



CAUTION: Allow cover to stand for 30 minutes before fitting.

11. Fit rocker cover to cylinder head, ensuring short bolts are fitted inboard, tighten bolts to **9 Nm, 7 lbf ft.**
12. Connect plug leads and secure to guide clips.
13. Align dipstick tube to rocker cover and tighten screw.
14. Fit plenum chamber. **See FUEL SYSTEM, Repair, plenum chamber**
15. Reconnect battery negative lead.



ROCKER COVER GASKET - RIGHT HAND

Service repair no - 12.29.41

Remove

1. Disconnect battery negative lead.

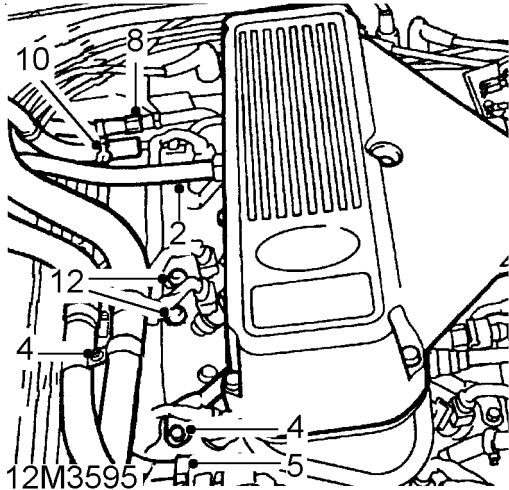

2. Disconnect breather hose from plenum chamber and remove hose from rocker cover.
3. Position container to collect coolant spillage.
4. Remove bolt securing coolant pipe brackets together and nut securing bracket to manifold.
5. Loosen clip and disconnect coolant return hose from manifold.
6. Depressurise fuel system. **See FUEL SYSTEM, Adjustment, fuel system depressurise**
7. Position cloth to absorb fuel spillage.
8. Disconnect fuel feed hose union.



CAUTION: Plug the connections.

9. Loosen clip and disconnect fuel return hose.



CAUTION: Plug the connections.

10. Remove 2 bolts securing engine harness bracket to manifold.

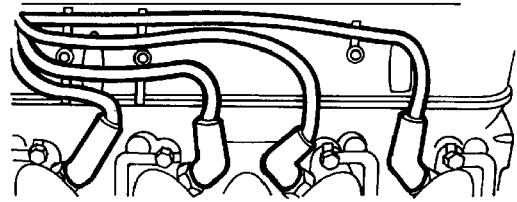

J6005

11. Release 4 spark plug leads from guide clips and disconnect leads from spark plugs.

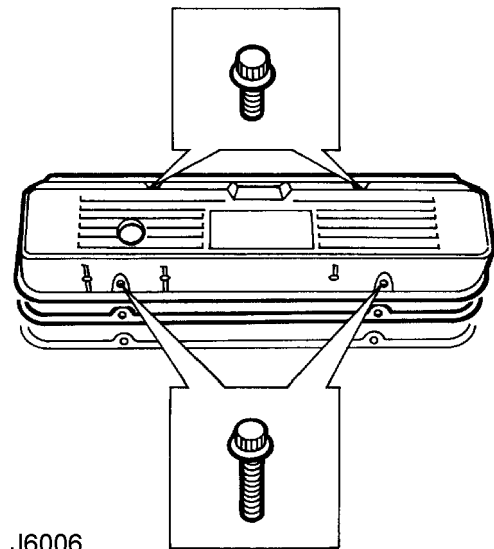

J6006

12. Remove 4 bolts securing rocker cover to cylinder head.
13. Remove rocker cover.
14. Remove and discard rocker cover gasket.

Refit

15. Clean mating faces of rocker cover and cylinder head using Bostick 6001 or equivalent. Allow to dry.
16. Apply a thin coating of impact adhesive (Bostick 1775 or equivalent) to mating faces of rocker cover and gasket. Use a brush to ensure an even film. Allow adhesive to become touch dry.



NOTE: Gasket only fits one way round. It must be fitted accurately, first time. Subsequent movement will destroy

bonding.

17. Place one end of gasket into cover recess with edge firmly against recess wall, holding remainder of gasket clear. Work around cover pressing gasket into place ensuring edge firmly contacts recess wall.



CAUTION: Allow cover to stand for 30 minutes before fitting.

18. Fit rocker cover to cylinder head ensuring short bolts are fitted inboard, tighten bolts to **9 Nm**.
19. Connect plug leads and secure to guide clips.
20. Position harness bracket to inlet manifold and tighten bolts.
21. Connect fuel feed and return hoses.
22. Connect coolant hose to inlet manifold and tighten clip.
23. Secure coolant pipe brackets
24. Fit breather hose.
25. Refill cooling system.
26. Reconnect battery negative lead.

ENGINE ASSEMBLY

Service repair no - 12.41.01

Remove

1. Position vehicle on '4-post' ramp [hoist].
2. Drain engine oil. **See SECTION 10, Maintenance, under vehicle maintenance**
3. Remove bonnet. **See CHASSIS AND BODY, Repair, bonnet**
4. Remove radiator. **See COOLING SYSTEM, Repair, radiator**
5. Loosen 3 PAS pump pulley bolts.
6. Using a 15 mm ring spanner, release auxillary drive belt tension and release belt from alternator pulley.
7. Remove drive belt.

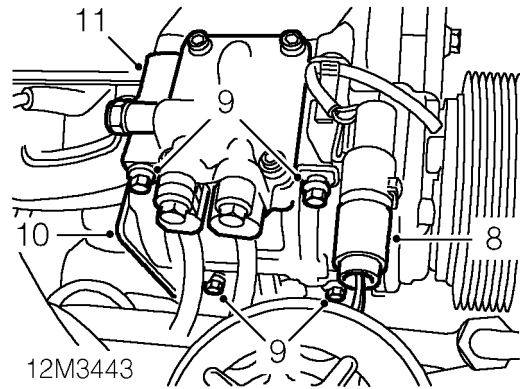

8. Disconnect A/C compressor multiplug.
9. Remove 4 bolts securing compressor to mounting bracket.
10. Collect compressor heat shield.
11. Tie compressor aside with string.

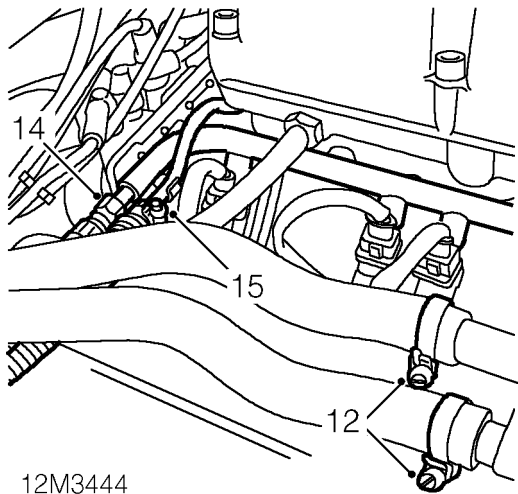

12M3444

12. Loosen clip screws securing heater return and feed hoses to pipes and disconnect.
13. Position cloth to collect fuel spillage.
14. Loosen fuel feed hose to rail union, allow fuel to spill and disconnect union.
15. Loosen clip screw securing fuel return hose to fuel rail and disconnect hose.



CAUTION: Plug the connections.

16. Remove cloth.
17. Remove plenum. *See FUEL SYSTEM, Repair, plenum chamber*

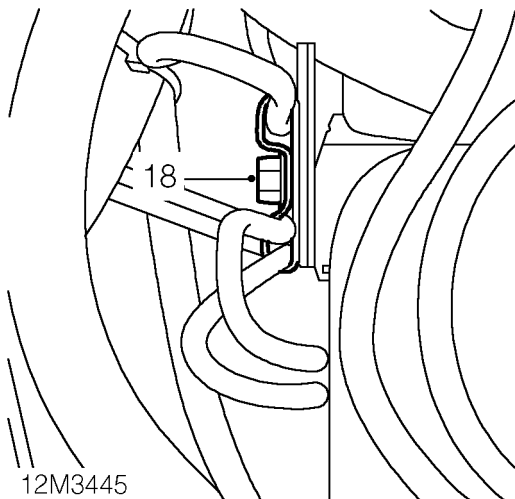

12M3445

18. Remove bolt securing 2 breather pipe 'P' clip to rear of RH cylinder head.

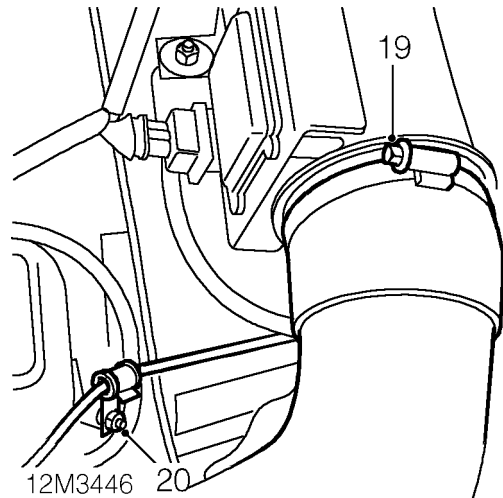

12M3446 20

19. Loosen clip screw securing intake hose to MAF sensor housing and remove hose.
20. Remove nut securing kick-down cable clip to rear of LH cylinder head.

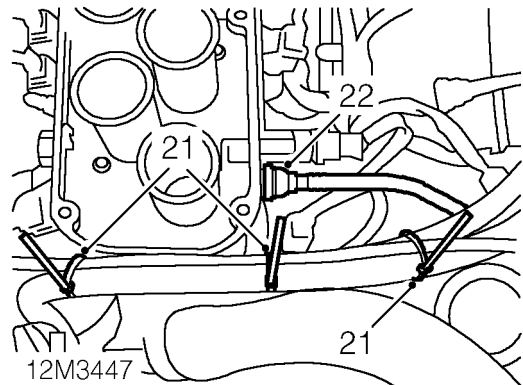

12M3447

21. Remove 3 cable ties securing purge pipe to coolant hose and harness, position pipe aside.
22. Disconnect brake servo pipe from inlet manifold and position aside.

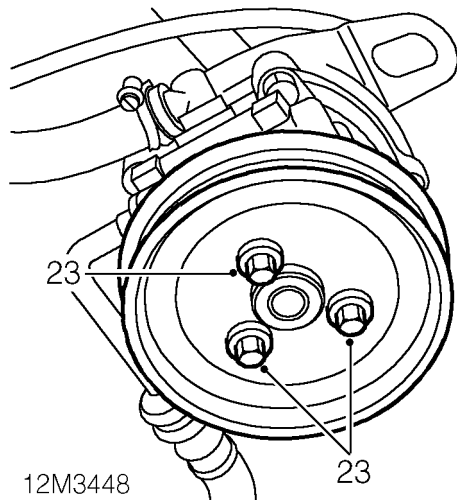

- 23.** Remove 3 bolts securing PAS pulley and remove pulley.

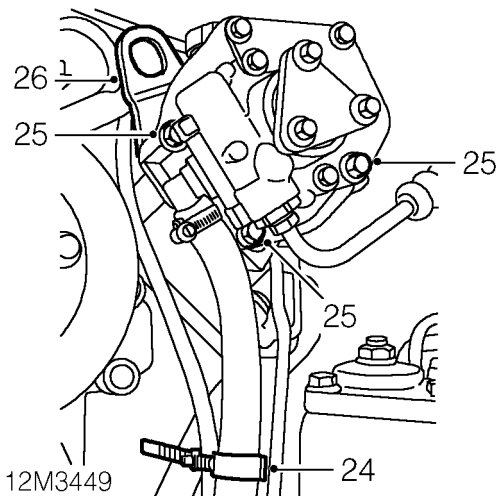

- 24.** Release knock sensor harness clip from PAS return hose.
25. Remove 3 bolts securing PAS pump and position aside.
26. Collect engine lifting bracket.

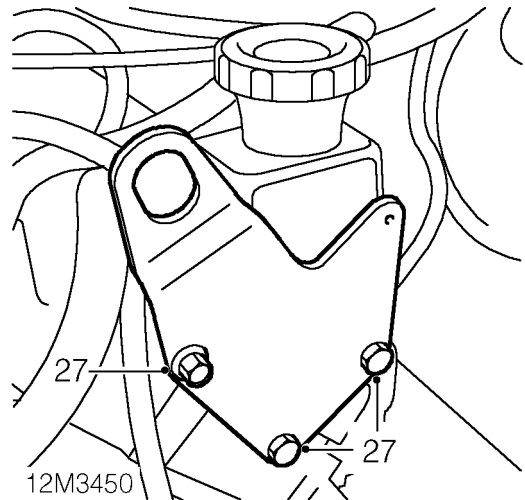

- 27.** Position engine lifting bracket and secure with 3 (3/8" UNC x 1" MAX) bolts.
28. Raise vehicle on ramp.
29. Remove 6 nuts securing exhaust front pipe to manifolds.
30. Remove front bolt securing RH catalyst heat shield to chassis.

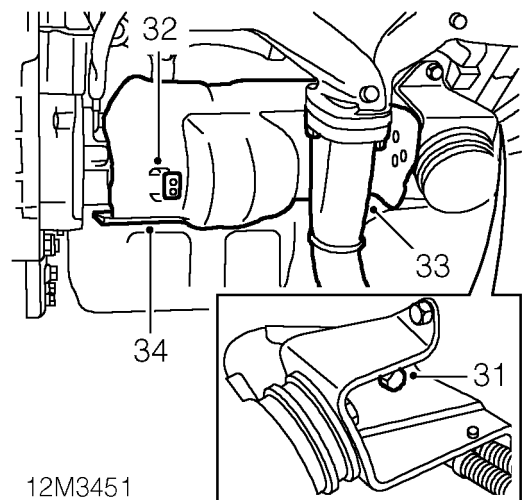

- 31.** Remove bolt securing starter motor heat shield to RH engine mounting bracket.
32. Release starter motor heat shield clip from solenoid.
33. Release exhaust front pipe from manifold studs and remove and discard gaskets.
34. Remove starter motor heat shield.

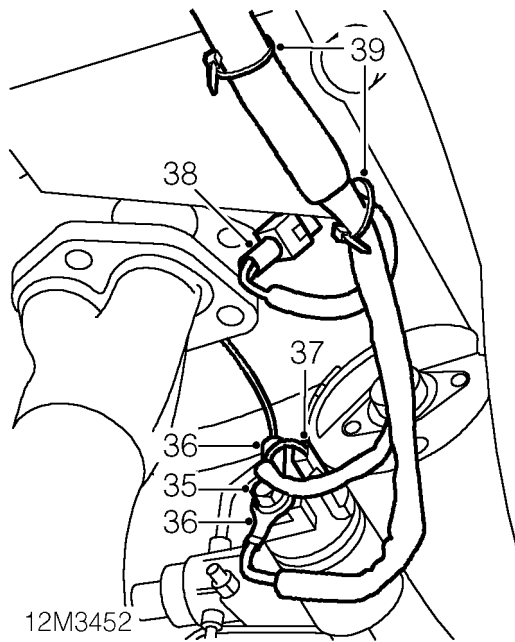

12M3452

35. Remove starter motor solenoid terminal nut.
36. Release 2 battery leads from terminal.
37. Disconnect solenoid Lucar.
38. Disconnect multiplug from RH Knock sensor.
39. Remove 2 cable ties securing engine harness to RH engine mounting bracket.

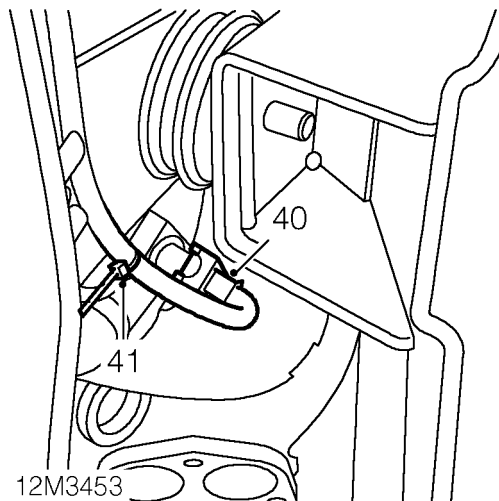

12M3453

40. Disconnect multiplug from LH knock sensor.
41. Remove cable tie securing engine harness to LH engine mounting bracket.

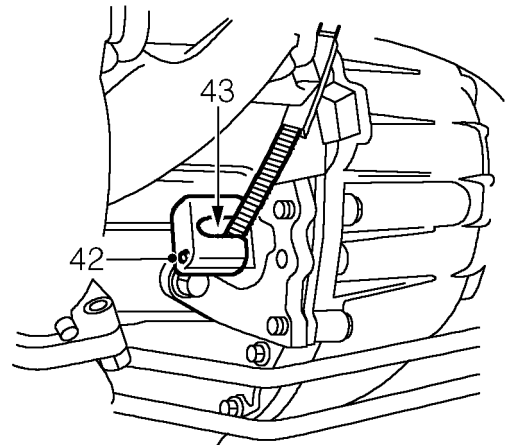

12M3454

42. Remove screw securing crankshaft position sensor heat shield and remove heat shield.
43. Disconnect multiplug from crankshaft position sensor.
44. Remove bolt securing gearbox cooler pipes to engine sump bracket.

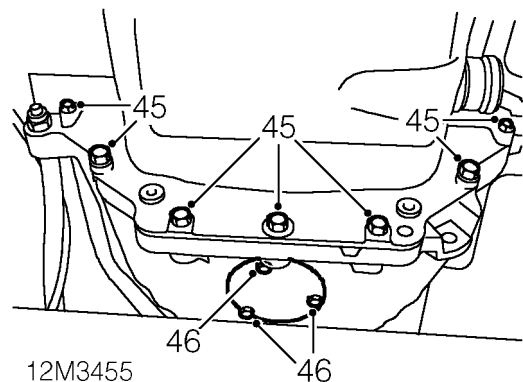

12M3455

45. Remove 7 bolts securing bell housing closing plate and remove plate.
46. Remove 3 bolts securing bell housing access plate and remove plate.

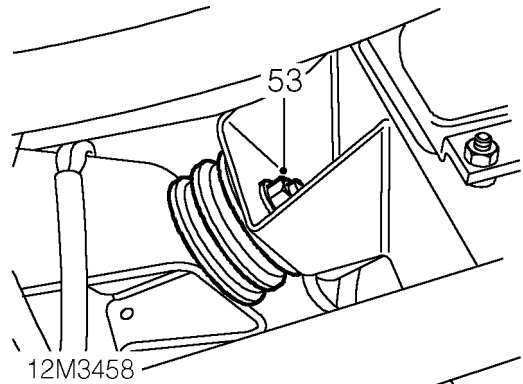
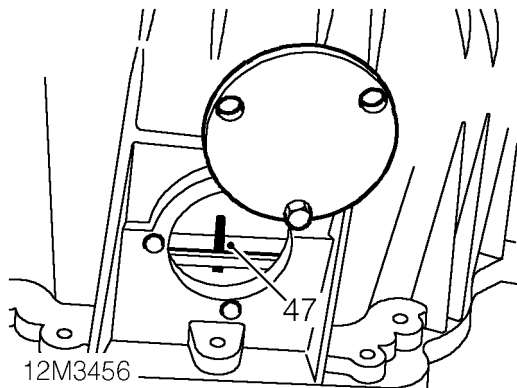

- 47. Mark relationship between converter and drive plate.
- 48. Rotate crankshaft to access drive plate to converter retaining bolts.

- 52. Remove nut securing RH engine mounting to chassis bracket.
- 53. Remove nut securing LH engine mounting to chassis bracket.
- 54. Lower vehicle.

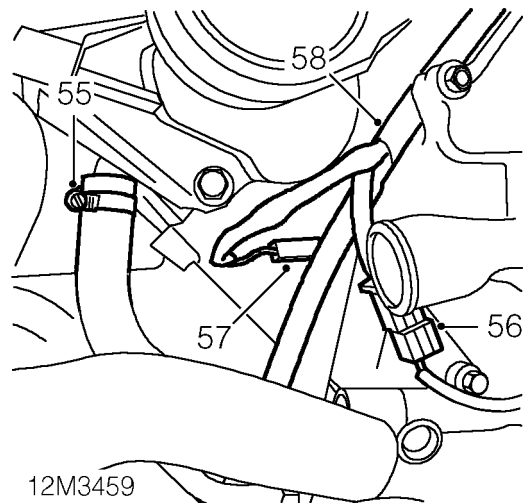
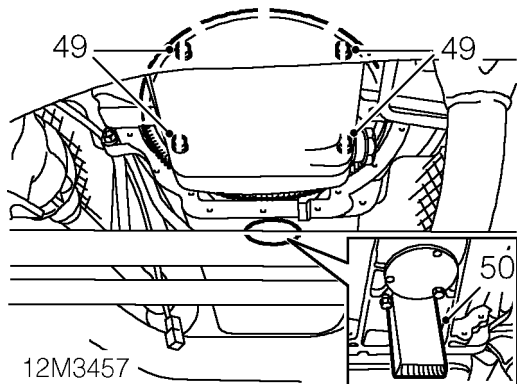

- 49. Remove 4 bolts securing drive plate to converter.
- 50. Fit suitable piece of wood through bell housing access hole to retain converter.
- 51. Remove 2 bell housing lower retaining bolts.

- 55. Loosen clip screw and disconnect radiator bottom hose from heater pipe.
- 56. Disconnect multiplug from camshaft position sensor.
- 57. Disconnect Lucar from oil pressure switch.
- 58. Release harness from front of engine.

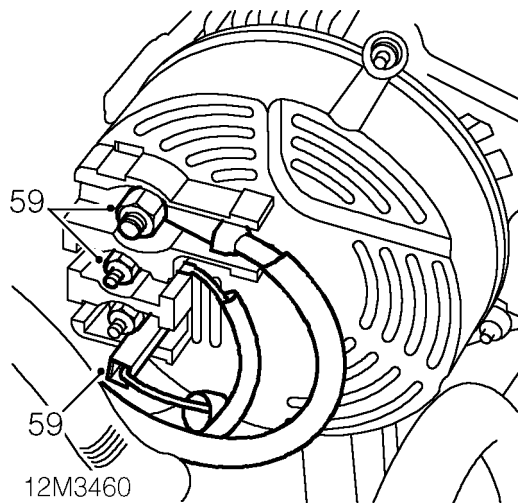

- 59.** Remove 2 alternator terminal nuts and disconnect Lucar.

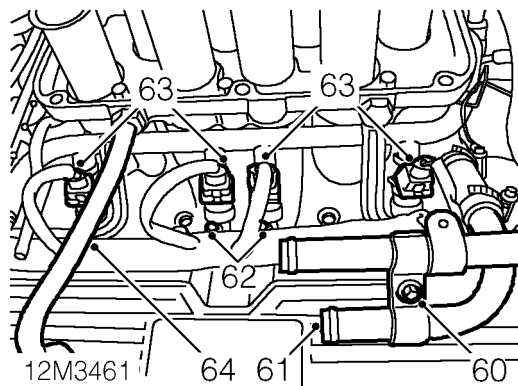

- 60.** Remove screw securing heater pipe to bracket.
61. Loosen clip screw and remove heater hose/pipe assembly from inlet manifold.
62. Remove 2 screws securing engine harness to RH side of inlet manifold.
63. Disconnect 4 RH injector multiplugs.
64. Disconnect RH rocker cover breather pipe from ram housing.

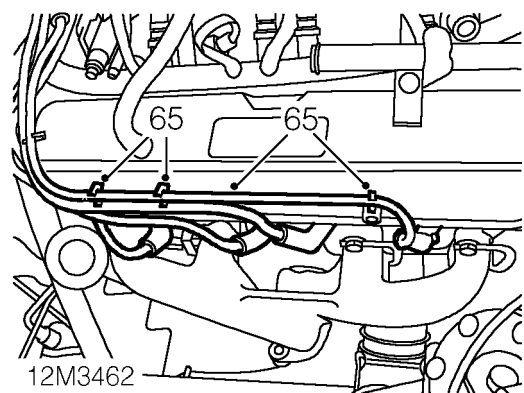

- 65.** Release RH bank HT leads from clips and disconnect from spark plugs.

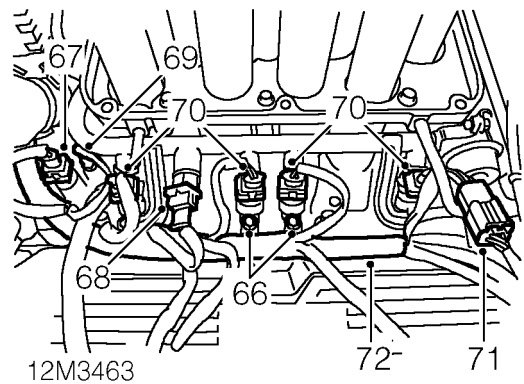

- 66.** Remove 2 screws securing engine harness to LH side of inlet manifold.
67. Disconnect multiplug from ECT sensor.
68. Disconnect multiplug from fuel temperature sensor.
69. Disconnect temperature sensor thermistor.
70. Disconnect 4 LH injector multiplugs.
71. Release ignition coil multiplug from mounting bracket and disconnect multiplug.
72. Position engine harness aside.

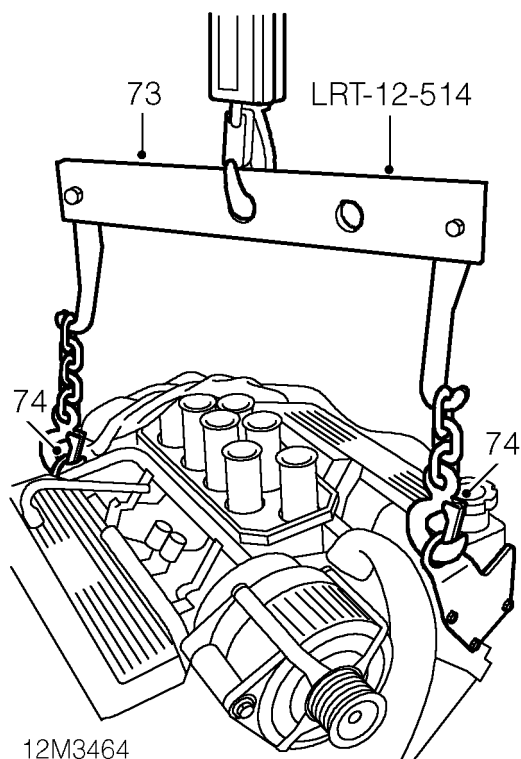

73. Fit engine lifting tool **LRT-12-514** to hoist.
74. Lower hoist and connect lifting chains to engine brackets.
75. Raise hoist until lifting chains become taught and use a jact to support gearbox.
76. Remove 6 bell housing to engine bolts.
77. With assistance, raise engine on hoist from engine compartment.

CAUTION: During the engine removal procedure ensure that the engine does not damage any surrounding components.

78. Move engine clear of vehicle and lower onto work bench.
79. Disconnect lifting chains from engine.
80. Raise hoist and position aside.

Refit

81. Clean engine and gearbox mating faces.
82. Clean dowel and dowel holes.
83. Position hoist above engine.
84. Connect lifting chains to engine.
85. Raise engine from work bench and position above engine compartment.

86. Position jack beneath gearbox fluid pan and raise transmission to ease alignment of bell housing to engine.



CAUTION: Use a block of wood or hard rubber pad to protect fluid pan.

87. With assistance, lower engine into engine compartment.



CAUTION: During the engine fitment procedure ensure that the engine does not damage any surrounding components.

88. With assistance, align engine to bell housing dowels.
89. Fit bolts securing bell housing to engine and tighten to **46 Nm, 34 lbf ft.**



NOTE: Align harness brackets to 2 uppermost bell housing retaining bolts.

90. Remove jack supporting gearbox fluid pan.
91. Lower engine hoist ensuring mountings are aligned with chassis brackets.
92. Disconnect lifting chains from engine eyes.
93. Remove lifting tool **LRT-12-514** from hoist.
94. Remove hoist from above vehicle.
95. Position engine harness around engine.
96. Connect ignition coil multiplug and secure to bracket.
97. Connect LH injector multiplugs.
98. Connect gauge temperature thermistor.
99. Connect multiplug to fuel temperature sensor.
100. Connect multiplug to ECT sensor.
101. Connect RH bank HT leads to spark plugs and secure to guides.
102. Connect RH rocker cover breather pipe to ram housing.
103. Connect RH injector multiplugs.
104. Align engine harness to RH side of inlet manifold and secure with screws.
105. Fit heater hose/pipe assembly to inlet manifold and secure with clip.
106. Align heater pipe to bracket and secure with screw.
107. Position alternator terminal leads and secure.
108. Route harness down front of engine.
109. Connect Lucar to oil pressure switch.
110. Connect multiplug to camshaft position sensor.
111. Connect radiator bottom hose to heater pipe and secure with clip.
112. Raise vehicle.



- 113. Fit nut securing LH engine mounting rubber to chassis mounting and tighten to **30 Nm, 22 lbf ft.**
- 114. Fit nut securing RH engine mounting rubber to chassis mounting and tighten to **30 Nm, 22 lbf ft.**
- 115. Fit bell housing to engine bolts and tighten to **46 Nm, 34 lbf ft.**
- 116. Remove piece of wood from bell housing access hole.
- 117. Align converter to drive plate.
- 118. Fit bolts securing converter to drive plate and tighten to **45 Nm, 33 lbf ft.**



NOTE: Rotate crankshaft during the above procedure.

- 119. Fit bell housing access plate and secure with bolts tightened to **9 Nm, 7 lbf ft.**
- 120. Clean bell housing cover plate and mating face.
- 121. Fit plate and secure with bolts tightened to **9 Nm, 7 lbf ft.**
- 122. Connect multiplug to crankshaft position sensor.
- 123. Fit crankshaft position sensor heat shield and secure with screw.
- 124. Position engine harness to LH engine mounting bracket and secure with cable tie.
- 125. Connect multiplug to LH knock sensor.
- 126. Position engine harness to RH engine mounting bracket and secure with cable ties.
- 127. Connect multiplug to RH knock sensor.
- 128. Connect Lucar to starter motor solenoid.
- 129. Position battery leads to starter motor solenoid terminal and secure with nut.
- 130. Position starter motor heat shield.
- 131. Clean exhaust manifold to front pipe mating faces.
- 132. Fit NEW front pipe to manifold gaskets.
- 133. Connect front pipe to manifold studs and secure with nuts.
- 134. Secure starter motor heat shield clip to solenoid.
- 135. Align starter motor heat shield to RH engine mounting bracket and secure with bolt.
- 136. Align RH catalyst heat shield to chassis and secure with bolt.
- 137. Lower vehicle.
- 138. Remove 3 bolts securing engine front lifting bracket, retain bracket but discard bolts.
- 139. Position engine lifting bracket to PAS pump, align to cylinder head and secure with bolts tightened to **35 Nm, 25 lbf ft.**
- 140. Secure knock sensor harness clip to PAS return hose.
- 141. Fit PAS pulley to pump, fit bolts but do not tighten.
- 142. Position brake servo pipe and connect to inlet manifold.
- 143. Position purge pipe and secure to coolant hose and harness with cable ties.
- 144. Fit intake hose to MAF sensor housing and secure with clip.
- 145. Position breather pipe 'P' clip to RH cylinder head and secure with bolt.
- 146. Fit plenum. **See FUEL SYSTEM, Repair, plenum chamber; Refit**
- 147. Remove plugs from fuel return and feed hose connections.
- 148. Clean fuel feed pipe connections.
- 149. Connect feed hose to fuel rail and tighten union.
- 150. Connect fuel return hose to fuel rail and secure with clip.
- 151. Connect heater feed and return hoses to pipes and secure with clips.
- 152. Release A/C compressor and position to mounting bracket.
- 153. Position heat shield to compressor fixing, fit bolts and tighten to **25 Nm, 18 lbf ft.**
- 154. Connect compressor multiplug.
- 155. Clean drive belt and pulley grooves.
- 156. Using a 15 mm spanner, rotate tensioner clockwise, fit belt to pulleys and release tensioner.
- 157. Tighten PAS pump pulley bolts to **10 Nm, 7 lbf ft.**
- 158. Fit radiator. **See COOLING SYSTEM, Repair, radiator**
- 159. Fit bonnet. **See CHASSIS AND BODY, Repair, bonnet**
- 160. Refill engine oil. **See SECTION 10, Maintenance, under vehicle maintenance**
- 161. Adjust kick-down cable. **See AUTOMATIC GEARBOX, Adjustment, kickdown cable adjustment**



TORQUE VALUES

Engine V8i	Nm	lbf ft
Crankshaft pulley bolt	270	200
Camshaft gear bolt	58	43
Timing cover / coolant pump bolts***	22	16
Rocker cover to cylinder head	9	7
Rocker shaft bracket to cylinder head	38	28
Spark plug	15	11
Cylinder head bolts:*		
Stage 1:	20	15
Stage 2:	then 90 °	then 90 °
Stage 3:	further 90 °	further 90 °
Generator / steering pump bracket to cylinder head	30	22
Lifting bracket to cylinder heads	40	30
Power steering hose unions:		
14 mm	15	11
16 mm	20	15
Power steering pump heat shield	25	18
Drive belt tensioner	50	39
Drive plate to converter	40	30
Drive plate to crankshaft	45	33
Drive plate hub aligner to crankshaft socket head screws	85	65
Bell housing bolts	40	30
Access plate	9	7
Bell housing cover plate	9	7
Main bearing cap rear bolts:		
Stage 1:	13	10
Stage 2:	72	53
Oil sump drain plug	40	30
Oil sump to cylinder block	23	17
Starter motor bolts	45	33
Starter motor shield	9	7
Oil cooler pipe unions to transmission	30	22
Tie bar to transmission	45	33
Gearbox breather pipe bracket	9	7
Engine harness bracket	9	7
Engine mountings to engine and chassis	55	40
Engine mounting rubbers to brackets	30	22
Compressor heat shield	25	18

* Lightly oil threads prior to assembly

** Apply Loctite 222 to threads before assembly

*** Apply Loctite 577 to threads before assembly



NOTE: The following torque values are for screws and bolts not specified in the previous table.

METRIC	Nm	lbf ft
M5	6	5
M6	9	7
M8	25	18
M10	45	33
M12	90	65
M14	105	75
M16	180	130

UNC / UNF		
1/4	9	7
5/16	25	18
3/8	40	30
7/16	80	60
1/2	90	65
5/8	135	100



EMISSION CONTROL

Three systems are used to control the vehicle atmospheric emissions, these are:

- Engine crankcase fume emissions.
- Fuel tank Evaporative emissions
- Engine exhaust gas emissions.

Crankcase ventilation system

The crankcase ventilation system, which is an integral part of the air supply to the engine combustion chambers, is often overlooked when diagnosing problems associated with engine performance. A blocked ventilation pipe or excessive air leak into the inlet system through a damaged pipe or leaking gasket can effect the mixture, performance and economy of the engine.

The purpose of the crankcase ventilation system is to ensure that any noxious gas generated in the engine crankcase is rendered harmless by burning in the combustion chambers as follows:

Oil laden noxious gas in the engine crankcase is drawn through an oil separator located in the RH cylinder head rocker cover, where the oil is separated and returned to the sump. The gas flows through a restrictor and via a hose into the inlet plenum chamber where it is drawn into the combustion chambers and burned. The volume of fresh air which is drawn from the atmospheric side of the throttle butterfly, via a hose into the LH rocker cover to mix with the gas, depends on the position of the throttle and the engine speed.

As the throttle opening increases, manifold depression increases, and at a given point, the crankcase gases are drawn into the throttle housing. This reversal helps to prevent excessive crankcase pressure or depression developing.

EXHAUST SYSTEM

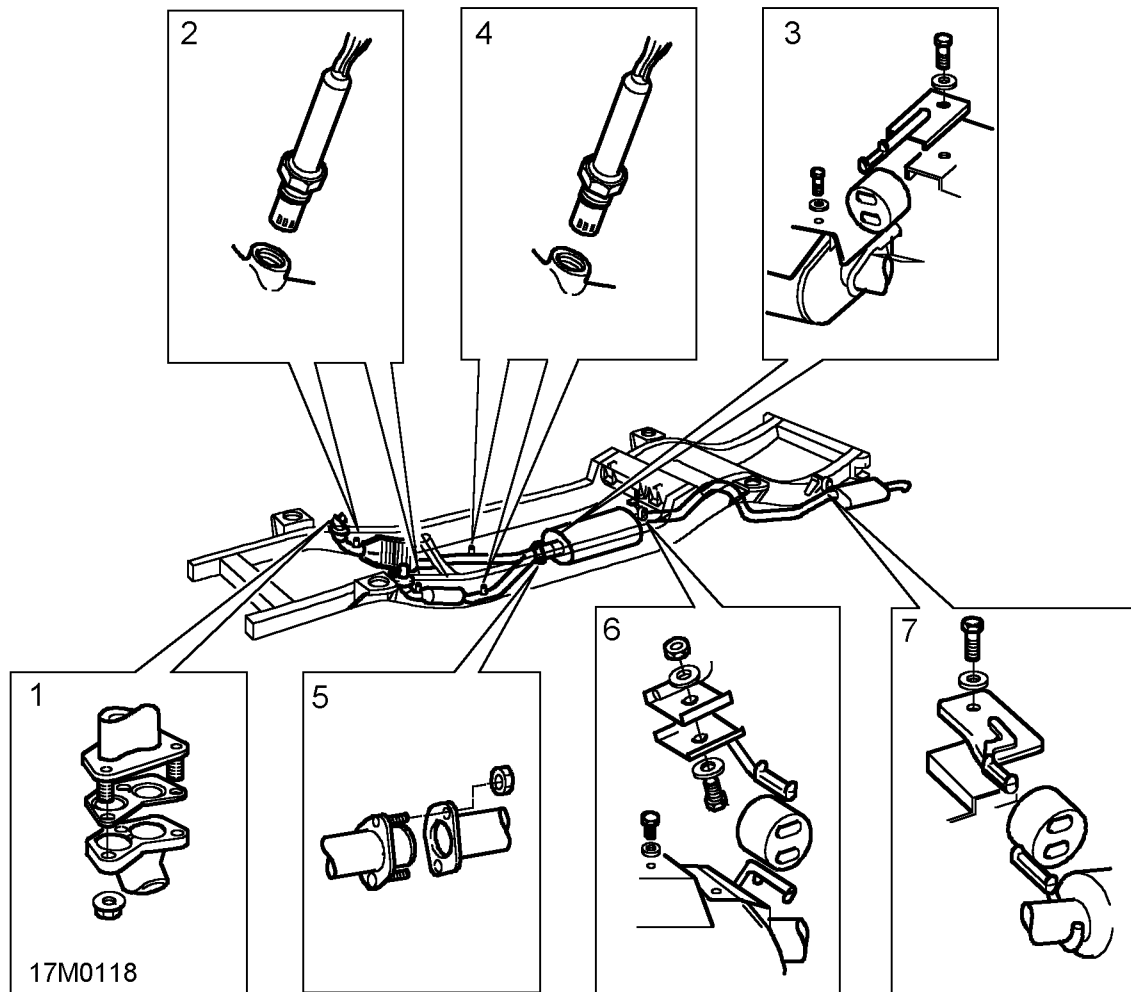

1. Manifold to front pipe connection.
2. Front oxygen sensor.
3. Front silencer support bracket.
4. Rear oxygen sensor.
5. Front pipe to silencer joint.
6. Silencer rear support bracket.
7. Rear silencer support bracket.



Exhaust emission control.

The multiport Sequential Fuel injection (SF_i) system provides accurately metered quantities of fuel to the combustion chambers to ensure the most efficient air to fuel ratio under all conditions of operation. A further improvement to combustion is made by measuring the oxygen content of the exhaust gases to enable the quantity of fuel injected to be varied, according to conditions, to correct any unsatisfactory composition of the exhaust.

The main components of the exhaust emission system are two catalytic converters which are an integral part of the front exhaust pipe assembly. The catalytic converters are included in the system to reduce the emission, to atmosphere, of carbon monoxide, oxides of nitrogen, and hydrocarbons. The active constituents of the converters are platinum and rhodium. The correct functioning of the converters is dependent upon close control of the oxygen concentration in the exhaust gas entering the catalyst. The oxygen content of the exhaust gas is signalled to the Engine Control Module (ECM) by Heated Oxygen Sensors (HO₂S) located in the exhaust front pipes each side of the catalytic converters. The ECM can then make an appropriate adjustment to the fuel supply to correct the composition of the exhaust gases.



CAUTION: Unleaded fuel only must be used on vehicles fitted with catalytic converters. As a reminder a label to indicate this is adhered to the inside of the fuel filler flap. As a further safeguard, the filler neck is designed to accommodate only unleaded fuel pump nozzles.

EVAPORATIVE EMISSION CONTROL SYSTEM

The system is designed to prevent harmful fuel vapour from escaping to the atmosphere. The system consists of a vapour separator tank, connected to the fuel tank and located between the body inner and outer panels on the right hand side of the vehicle near the rear wheel arch. An Evaporative Emissions (EVAP) canister, containing activated charcoal, is positioned in the engine compartment attached to the front right valance. The two components are connected by a pipe running the length of the chassis.

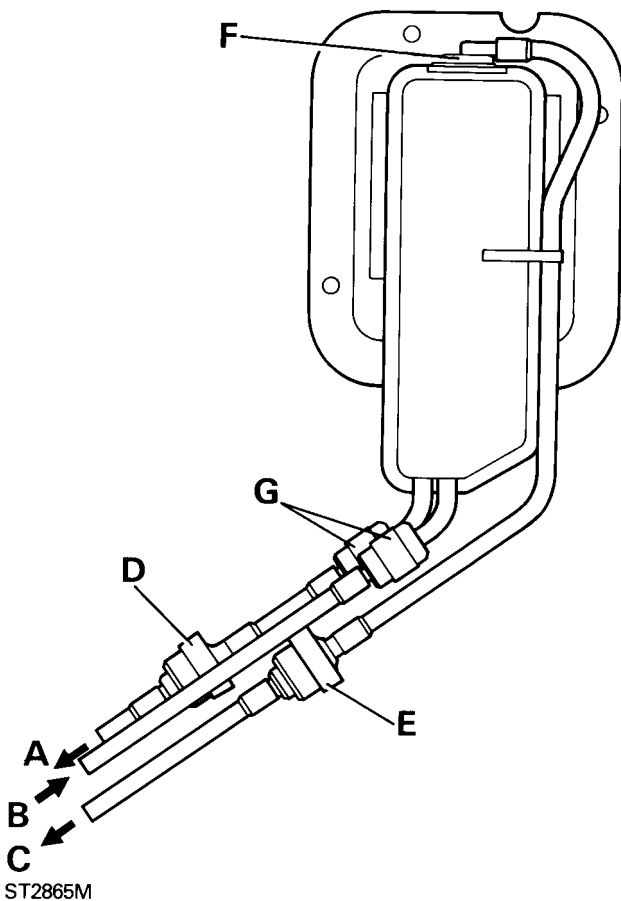

- A Pressure relief to atmosphere.
- B From fuel tank to separator.
- C To evaporative emissions canister.
- D Pressure relief valve.
- E Pressure relief valve.
- F Shut-off valve.
- G "Speed Fit" connectors.

A pressure relief valve is fitted in the hose which is open to atmosphere. This valve acts as a safety valve should a build-up of pressure occur in the system, for example if a hose became blocked or kinked. The volume of vapour emitted, in such an instance, would be limited.

A pressure relief valve is also fitted in the hose connected to the adsorption canister and releases vapor to the canister when the pressure in the separator reaches between 5 and 7 Kpa, 0.7 and 1.0 lbf/in².

In the top of the separator a shut-off valve is incorporated in the vapour exit port to prevent the possible presence of any liquid fuel being transmitted to the EVAP canister should the vehicle roll over.

The EVAP canister, which is connected by a hose to the plenum chamber, absorbs and stores the fuel vapour from the fuel tank while the engine is not running. When the engine is started, the vapour is purged from the canister by air drawn through an orifice in the base of the canister and by the influence of vacuum at the top. The vapour drawn into the plenum chamber through a solenoid operated purge valve is finally burnt in the combustion chambers.

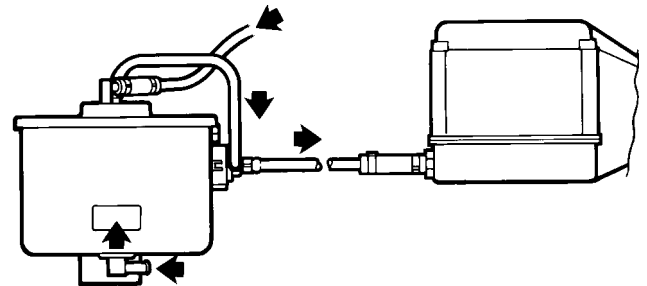

The purge valve, which is attached to the evap canister support bracket, is controlled by the Engine Control Module ECM which determines the optimum time at which purging should take place. This will normally be at engine speeds above idle and when the vehicle is in motion. A signal from the ECM to the purge valve operates the solenoid and opens the valve to purge the canister of fuel vapour.

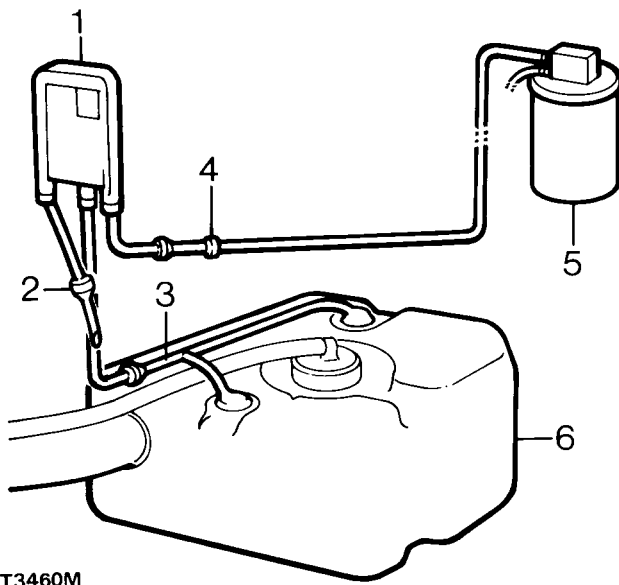

ST3460M

1. Vapour separator and pipes
2. Non-return valve to atmosphere
3. Pipe from fuel tank
4. Pipe to EVAP canister
5. EVAP canister and purge valve
6. Fuel tank



TESTING EVAPORATIVE EMISSION CONTROL

Equipment required.

Nitrogen cylinder (compressed air may be used to pressure the system when there has NEVER been fuel present in the fuel or evaporative control systems).

The following pressure test procedure is intended to provide a method for ensuring that the system does not leak excessively and will effectively control evaporative emissions.

Water manometer (0 - 30" H₂O or more).

Pipework and a "T" piece.

Method.

1. Ensure that there is at least two gallons of fuel in the petrol tank unless there has never been any fuel in the system.
2. Disconnect, at the EVAP canister, the pipe to the vapour separator.
3. Connect this pipe to the nitrogen cylinder and the water manometer using the "T" piece.
4. Pressurize the system to between 26.5 and 27.5 inches of water, allow the reading to stabilize, then turn off the nitrogen supply.
5. Measure the pressure drop within a period of 2 minutes 30 seconds. If the drop is greater than 2.5 inches of water the system has failed the test. Note that a fully sealed system will show a slight increase in pressure.
6. Should the system fail the test, maintain the pressure in the system and apply a soap solution round all the joints and connections until bubbles appear to reveal the source of the leak.
7. Repeat the test and if successful, dismantle the test equipment and reconnect the pipe to the EVAP canister.



EVAP CANISTER AND PURGE CONTROL VALVE

Service repair no - 17.15.13

Remove

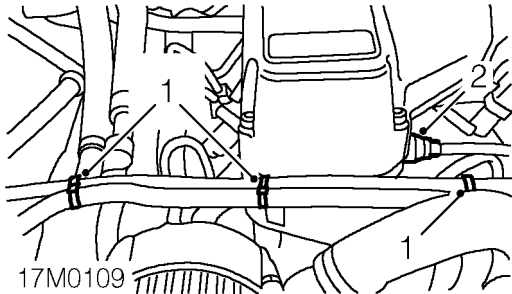

1. Remove 3 clips securing purge pipe to coolant hose.
2. Depress tags and disconnect purge pipe from plenum chamber.

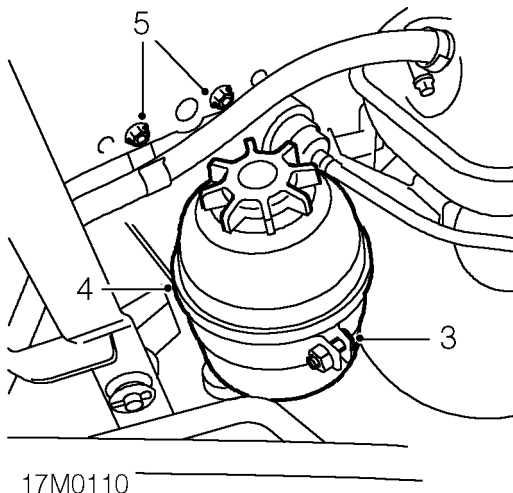

3. Remove PAS reservoir clamp bracket bolt.
4. Open clamp and release reservoir from bracket.
5. Remove 2 nuts securing bracket to wing.

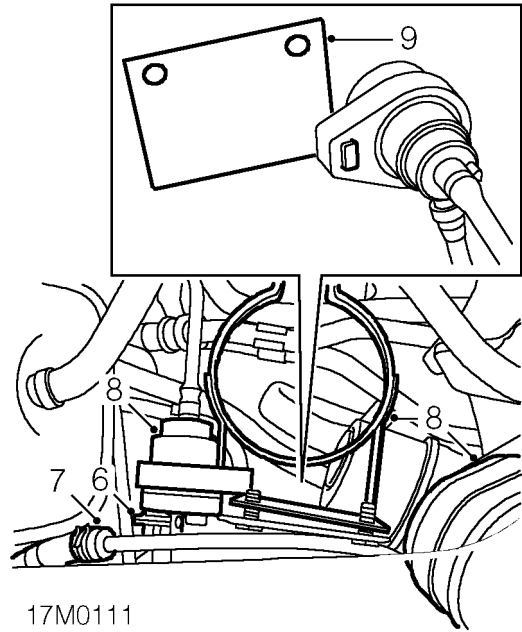

6. Release bracket from wing and disconnect multiplug from purge valve.
7. Release clip and disconnect fuel tank vapour separator pipe from canister pipe.
8. Move PAS reservoir aside, release and remove charcoal canister, purge valve and bracket assembly.

Do not carry out further dismantling if component is removed for access only.

9. Remove bracket from purge valve.

Refit

10. Fit bracket to purge valve.
11. Position assembly, connect vapour separator pipe to canister pipe and secure with clip.
12. Locate purge valve bracket and expansion hose clip to studs and locate assembly to wing.
13. Fit and tighten nuts.
14. Locate PAS reservoir to bracket clip, compress clip, fit bolt and tighten to **8 Nm, 6 lb ft.**
15. Connect purge pipe to plenum chamber.
16. Secure purge pipe to coolant hose with clips.

VAPOUR SEPARATOR

Service repair no - 17.15.19

Remove

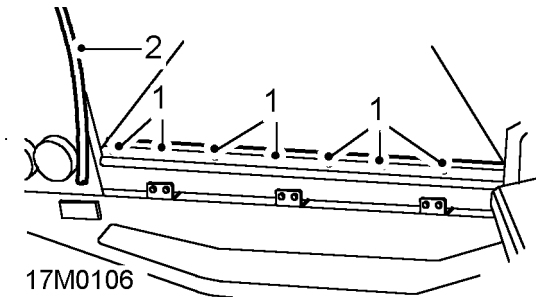

1. Remove 7 screws securing floor carpet rear retainer.
2. Release lower section of door sealing rubber on one side.
3. Remove carpet retainer.

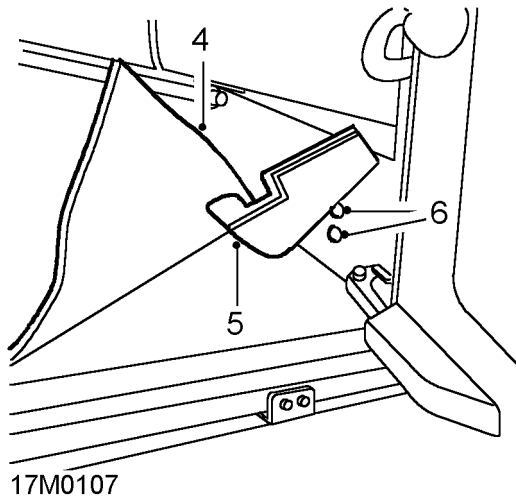

4. Fold floor carpet back on RH side.
5. Release RH side carpet and move aside to reveal 2 screws securing vapour separator.
6. Remove 2 screws securing vapour separator.

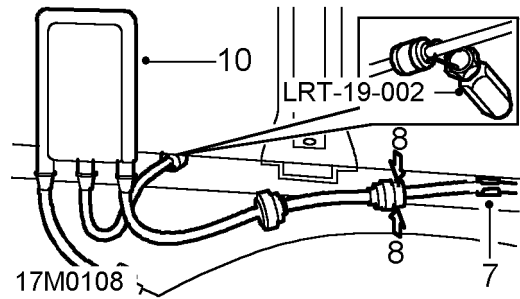

7. Release vapour separator pipe from clip on fuel pipe.
8. Depress 2 lugs on vapour separator connector and disconnect pipe.
9. Using tool **LRT-19-002** depress collar at green end of 'speedfit' connector and disconnect pipe.
10. Remove vapour separator.

Refit

11. Position vapour separator and connect pipes.
12. Using assistance, align vapour separator and fit and tighten screws.
13. Apply adhesive to side carpet and body.
14. Fold down side and floor carpets.
15. Fit carpet retainer and fit and tighten screws.
16. Secure door sealing rubber.



FRONT PIPE / CATALYTIC CONVERTER

Service repair no - 17.50.09

Remove



WARNING: The removal of the exhaust system must only be carried out when the engine is cold.

1. Raise vehicle on ramp.
2. Remove oxygen sensors. *See FUEL SYSTEM, Repair, Heated oxygen sensor (ho2s) - front* and *See FUEL SYSTEM, Repair, Heated oxygen sensor (ho2s) - rear*

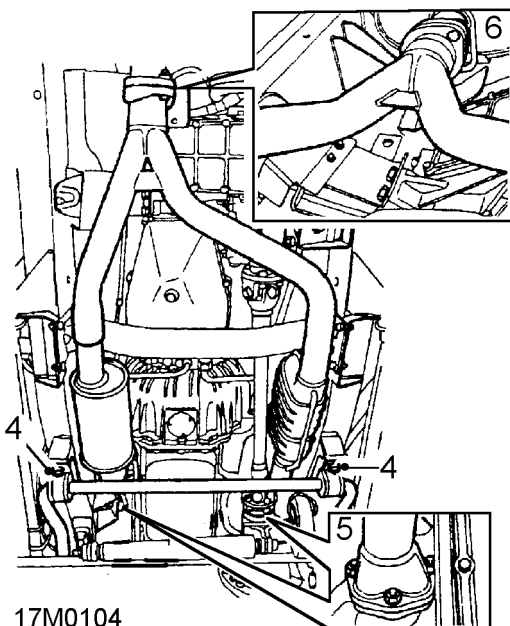

17M0104

3. Remove 4 bolts securing front anti-roll [sway] bar mounting brackets.
4. Remove 6 nuts securing front pipe assembly to exhaust manifolds.
5. Remove 2 nuts securing front pipe assembly to intermediate pipe.
6. With assistance, release front pipe assembly from exhaust manifolds.
7. With assistance, release front pipe assembly from intermediate pipe.
8. With assistance, lower anti-roll [sway] bar and remove front pipe assembly.
9. Remove and discard flange gaskets.

Refit

10. Clean exhaust flange mating faces.
11. Fit new flange gaskets.
12. With assistance, position front pipe to vehicle.
13. With assistance, locate front pipe on exhaust manifolds and intermediate pipe.
14. Fit and tighten flange nuts.
15. Reposition front anti-roll [sway] bar and secure with bolts.
16. Fit heated oxygen sensors. *See FUEL SYSTEM, Repair, Heated oxygen sensor (ho2s) - front* and *See FUEL SYSTEM, Repair, Heated oxygen sensor (ho2s) - rear*
17. Lower vehicle.



ENGINE MANAGEMENT SYSTEM COMPONENT LOCATION

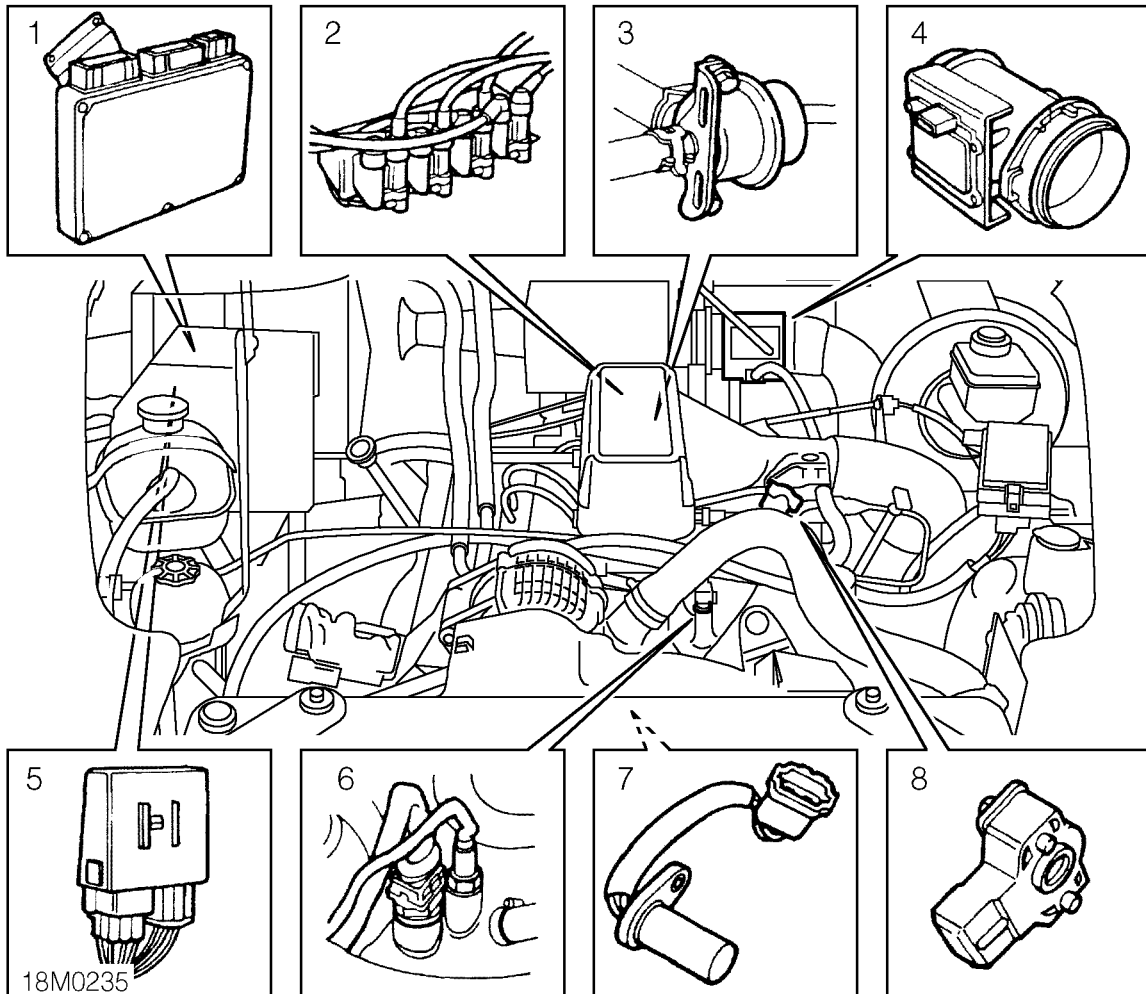

1. Engine Control Module (ECM)
2. Ignition coils
3. Fuel pressure regulator
4. Mass air flow (MAF) sensor
5. Relay module
 - Main relay
 - Fuel pump relay
6. Engine coolant temperature (ECT) sensor
7. Camshaft position (CMP) sensor
8. Throttle position (TP) sensor

19 FUEL SYSTEM

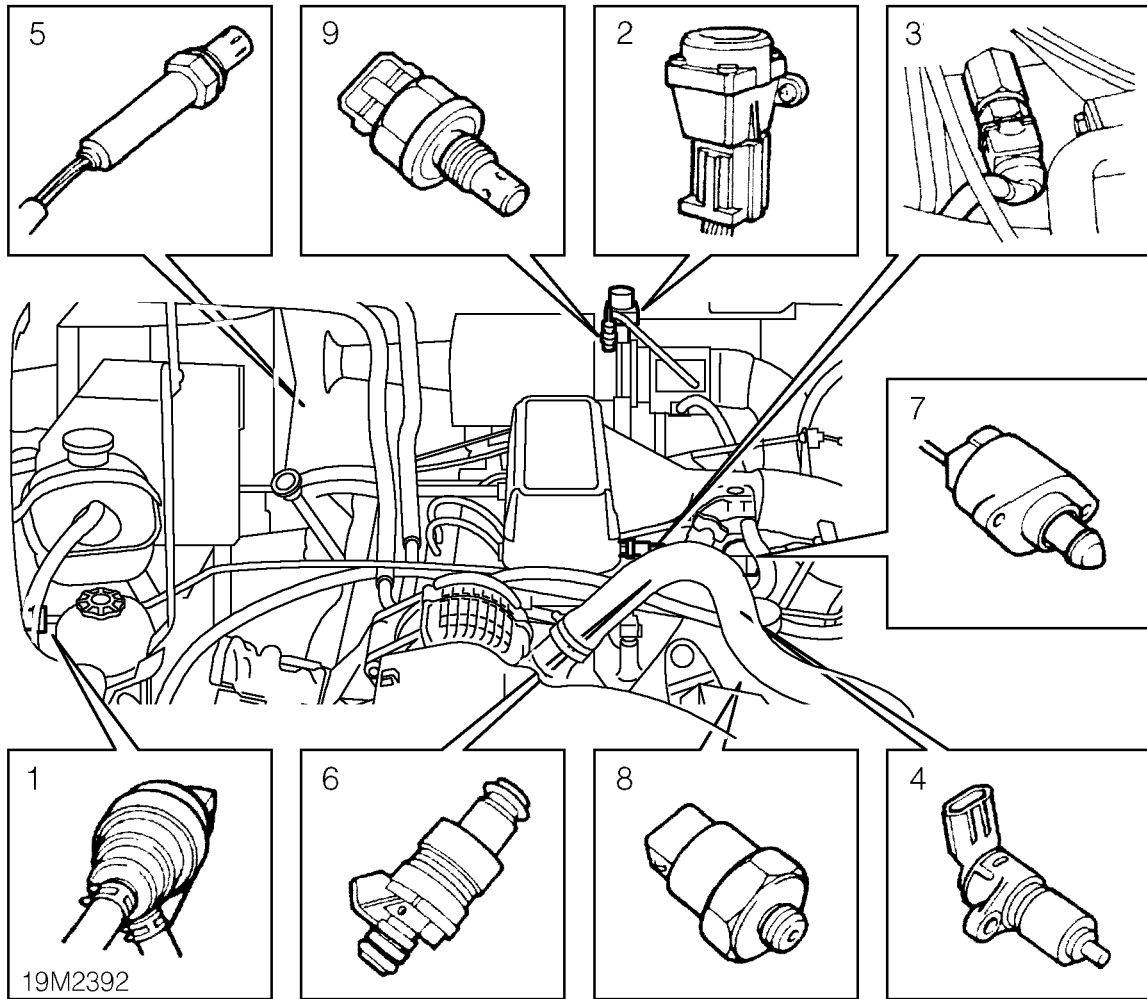

1. EVAP purge valve
2. Inertia switch
3. Engine fuel temperature (EFT) sensor
4. Crankshaft position (CKP) sensor
5. Heated oxygen sensor (HO2S) - 4 off
6. Injectors - 8 off
7. Idle air control valve (IACV)
8. Knock sensors - 2 off
9. Intake air temperature (IAT) sensor



ENGINE MANAGEMENT SYSTEM

Description

The engine management system (EMS) maintains optimum engine performance over the entire operating range. The correct amount of fuel is metered into each cylinder inlet tract and the ignition timing is adjusted at each spark plug.

The system is controlled by the Engine Control Module (ECM) which receives data from sensors located on and around the engine. From this information it provides the correct fuel requirements and ignition timing to suit all engine loads and speeds.

The fuel injection system uses a hot wire Mass Air Flow sensor to calculate the amount of air flowing into the engine.

The ignition system does not use a distributor. It is a direct ignition system (DIS), using four double ended coils. The circuit to each coil is completed by switching inside the ECM.

The on board diagnostic system detects any faults which may occur within the EMS. Fault diagnosis includes failure of all EMS sensors and actuators, emissions related items, fuel supply and exhaust systems.

The system incorporates certain default strategies to enable the vehicle to be driven in case of sensor failure. This may mean that a fault is not detected by the driver. The fault is indicated by illumination of the malfunction indicator light (MIL).

Crankshaft position (CKP) sensor

The crankshaft position sensor is the most important sensor on the engine. It is located in the left hand side of the torque convertor housing. The signal it produces informs the ECM:

- that the engine is turning
- how fast the engine is turning
- at which stage the engine is, in the combustion cycle.

As there is no default strategy, failure of the crankshaft sensor will result in the engine failing to start. The fault is indicated by illumination of the malfunction indicator light (MIL).

Camshaft position (CMP) sensor

The camshaft position sensor is located in the engine front cover. It produces four pulses every two revolutions. The signals are used in two areas, injector timing corrections for fully sequential fuelling and active knock control.

If the camshaft sensor fails, default operation is to continue normal ignition timing. The fuel injectors will be actuated sequentially, timing the injection with respect to top dead centre. Injection will either be correct or one revolution out of synchronisation. The fault is not easily detected by the driver. Sensor failure will be indicated by illumination of the malfunction indicator light (MIL).

Mass air flow (MAF) sensor

The 'hot wire' type mass air flow sensor is mounted rigidly to the air filter and connected by flexible hose to the plenum chamber inlet. The sensing element of the MAF Sensor is a wire which is heated. Air flows across the heated wire cooling it and thus changing its resistance. The ECM measures this change in resistance, and together with intake air temperature sensor resistance, calculates the amount of air flowing into the engine.

As there is no default strategy, failure will result in the engine starting, and dying when it reaches 550 rev/min, when the ECM detects no MAF Sensor signal. The fault is indicated by illumination of the malfunction indicator light (MIL) on North American specification vehicles.

Throttle position (TP) sensor

The throttle position sensor is mounted on the plenum chamber and connected directly to the throttle shaft. The sensor is a variable resistor, the signal from which (0 - 5V) informs the ECM of the actual position of the throttle disc. As there is no default strategy, failure of the sensor will result in poor idle and lack of throttle response. If failure occurs in the closed position the engine will only reach 1750 rev/min when the ECM will initiate overrun fuel cut off. The fault is indicated by illumination of the malfunction indicator light (MIL).

Engine coolant temperature (ECT) sensor

This sensor consists of a temperature dependant resistive metal strip. The resistance of the strip varies considerably with coolant temperature, i.e.

- 28K ohms at 30°C, 86°F
- 300 ohms at 85°C, 185°F
- 90 ohms at 130°C, 266°F

The ECT Sensor signal is vital to engine running, as the correct fuelling is dependant upon engine temperature i.e. richer mixture at low temperatures. If the sensor is disconnected or failure occurs a default value will be supplied to the system. The initial default value selected will be based on the value of the air intake temperature. This will increase to a nominal warmed up value over an individual time, programmed for each default value. The fault may not be evident to the driver, though there may be a hot restart problem. The fault is indicated by illumination of the malfunction indicator light (MIL).

Intake air temperature (IAT) sensor

This is another resistive sensor, located in the body of the air cleaner. The resistance varies with changes in air temperature. The signal from the IAT Sensor is used to retard the ignition timing if the air temperature rises above 55°C. If the sensor is disconnected or failure occurs a default value will be supplied to the system. The default value selected will represent normal operating conditions. The fault may not be evident to the driver, there may be slight power loss in high ambient temperatures. The fault is indicated by illumination of the malfunction indicator light (MIL) on North American specification vehicles.

Engine fuel temperature (EFT) sensor

The EFT sensor is located on the fuel rail. This sensor measures temperature of the rail rather than the fuel. The resistance varies with changes in temperature. The signal is used to increase the injection pulse time when undergoing hot restarts. When the fuel is hot, vapourisation occurs in the rail which may result in the formation of bubbles in the injectors. Increasing the pulse time helps flush the bubbles away and cools the fuel rail with fuel from the tank.

An EFT sensor fault may not be evident to the driver, there may be a hot restart problem. The fault is indicated by illumination of the malfunction indicator light (MIL).

Knock sensors

The knock sensor produces an output voltage in proportion to mechanical vibration caused by the engine. A sensor is located in each cylinder bank between 2/4 and 3/5 cylinders. The ECM calculates if the engine is knocking by taking camshaft and crankshaft sensor signals to determine the position of the engine in the combustion cycle.

The ECM can also work out exactly which cylinder is knocking and retards the ignition on that particular cylinder until the knock disappears. It then advances the ignition to find the optimum ignition timing for that cylinder.

The ECM can simultaneously adjust the timing of each cylinder for knock . It is possible that all eight cylinders could have different advance angles at the same time. If the camshaft sensor fails, the knock sensor will continue to work, but as the engine may be running one revolution out of sychronisation the ECM may retard the wrong cylinder of the pair e.g. 1 instead of 6. If the knock sensor fails engine knock will not be detected and corrected. The fault is indicated by illumination of the malfunction indicator light (MIL).

Rough Road Detection

With the vehicle in motion, the rough road detection ECU receives signals from a speed sensor mounted at each wheel. The system checks for differing wheel speeds and uses this information to determine when the vehicle is off road, to prevent the ECM logging false misfires.



Ignition coils

The electronic ignition system uses four double ended coils. They are mounted on a bracket fitted to the rear of the engine. The circuit to each coil is completed by switching within the ECM, allowing each coil to charge up and fire. Sparks are produced in two cylinders simultaneously, one on compression stroke, the other on exhaust stroke. Note that coil 1 feeds cylinders 1 and 6, coil 2 feeds cylinders 5 and 8, coil 3 feeds cylinders 4 and 7, and coil 4 feeds cylinders 2 and 3. The resistance of the spark in the compression cylinder is higher than that in the exhaust cylinder. Coil failure will result in a lack of ignition, resulting in misfire in the effected cylinders. The fault is indicated by illumination of the malfunction indicator light (MIL) on North American specification vehicles.

Injectors

A multiport Sequential Fuel injection (SFI) system is used, one injector per cylinder. Each injector consists of a small solenoid which is activated by the ECM to allow a metered amount of fuel to pass into the combustion chamber. Due to the pressure in the fuel rail and the shape of the injector orifice, the fuel squirts into the cylinder in a fine spray to aid combustion. In the unlikely event of total injector failure or leakage which will cause rich mixture, a misfire will occur in the affected cylinder. The fault is indicated by illumination of the malfunction indicator light (MIL) on North American specification vehicles.

Idle air control (IAC)

Idle speed is controlled by a stepper motor which consists of two coils. When energised in the correct sequence the coils move a plunger which opens and closes the throttle bypass controlling the quantity of idle air. The stepper motor controls idle speed by moving the plunger a set distance called a step. Fully open is 200 steps and fully closed 0 steps. Failure of the stepper motor will result in low or high idle speed, poor idle, engine stall or non start. The fault is indicated by illumination of the malfunction indicator light (MIL) on North American specification vehicles.

Heated oxygen sensor (HO2S)

The oxygen sensors consist of a titanium metal sensor surrounded by a gas permeable ceramic coating. Oxygen in the exhaust gas diffuses through the ceramic coating on the sensor, and reacts with the titanium wire altering the resistance of the wire. From this resistance change the ECM calculates the amount of oxygen in the exhaust gas. The injected fuel quantity is then adjusted to achieve the correct air/fuel ratio, thus reducing the emissions of carbon monoxide (CO), hydrocarbons (HC), and oxides of nitrogen (NO_x). Four HO2 sensors are fitted in the exhaust front pipe, two each side, and positioned in front and behind each catalyst. The two rear sensors are used to monitor the operating efficiency of the catalysts. Note that if the wiring to these sensors is crossed, the vehicle will start and idle correctly until the sensors reach operating temperature. Then the ECM will read the signals from them and send one bank of cylinders very rich and the other very weak. The engine will misfire, have a rough idle and emit black smoke, with possible catalyst damage.

In the event of sensor failure, the system will default to 'open loop' and fuelling will be calculated using signals from the remaining ECM inputs.

A fault is indicated by illumination of the malfunction indicator light (MIL). ECM diagnostics also use HO2 sensors to detect catalyst damage, misfire and fuel system faults.

Fuel pressure regulator

The fuel pressure regulator is a mechanical device controlled by manifold depression and is mounted at the rear of the engine in the fuel rail. The regulator ensures that fuel rail pressure is maintained at a constant pressure difference to that in the inlet manifold, as manifold depression increases the regulated fuel pressure is reduced in direct proportion.

When pressure exceeds the regulator setting excess fuel is spill returned to the fuel tank swirl pot which contains the fuel pick-up strainer.

Failure of the regulator will result in a rich mixture at idle but normal at full load, or a rich mixture resulting in engine flooding, or a weak mixture. Although the fault will not illuminate the MIL, faults caused by the failure may be indicated.

Relay module

The engine management system employs a relay module, which houses the main relay and the fuel pump relay.

Main relay

The main relay supplies the power feed to the ECM and, the fuel injectors (8 amps) and mass air flow sensor (4 amps). This relay is controlled by the ECM. This enables the ECM to remain powered up after ignition is switched off.

During the 'ECM power down routine' the ECM records all temperature readings and powers the stepper motor to the fully open position. Failure of this relay will result in the ECM not being switched on resulting in engine not starting due to absence of fuel and ignition.

Fuel pump relay

The fuel pump relay is fed from the ignition relay and controlled by the ECM. The relay is activated in ignition key position 2 to prime the fuel system for a period of time controlled by the ECM. Failure of this relay will result in no fuel pressure.

Inertia fuel shut-off switch

The inertia switch isolates the power supply to the fuel pump in the event of sudden deceleration. The inertia switch is located in the engine compartment. It is reset by depressing the central plunger at the top of the switch.

Engine immobilization

A coded signal is sent from the immobilization unit, located behind the instrument panel, to the vehicle ECM. If the coded signal does not match the signal expected by the ECM, the ECM immobilizes the starting and fuel circuits.



ENGINE TUNING

Service repair no - 19.22.13

The position of the Idle Air Control (IAC) valve can be checked using TestBook and adjusted if necessary through the by-pass screw in the plenum chamber. The bypass screw is covered by a tamper proof plug which can be extracted using a self tapping screw.

All vehicles:

1. Ensure air conditioning and all electrical loads are off. Vehicle must be in neutral or park.
2. Carry out tuning or base idle setting procedure as applicable using TestBook.

FUEL SYSTEM DEPRESSURISE

Service repair no - 19.50.02



WARNING: Fuel pressure of up to 2.5 bar will be present in the system, even if the engine has not been run for some time.

Always depressurise the system before disconnecting any components in the fuel feed line (between fuel pump and pressure regulator). The spilling of fuel is unavoidable during this operation. Ensure that all precautions are taken to prevent fire and explosion.



NOTE: Fuel pressure can be relieved at fuel rail feed union or fuel filter unions.

1. Position cloth around relevant union to protect against fuel spray.
2. Carefully loosen union.
3. Tighten union to correct torque once pressure is relieved.

FUEL TANK DRAIN

Service repair no - 19.55.02



WARNING: Ensure that Fuel Handling Precautions given in Section 01 - Introduction are strictly adhered to when carrying out following instructions.



CAUTION: Before disconnecting any part of the fuel system, it is imperative that all dust, dirt and debris is removed from around components to prevent ingress of foreign matter into fuel system.

1. Disconnect battery negative lead.
2. Remove fuel filler cap.
3. Using a fuel bowser with an 18 mm, 0.75 in outside diameter hose, pass hose into tank through filler neck.



NOTE: Because the fuel tank filler stub houses a restrictor, repeated attempts may be necessary to enter the hose into the fuel tank. Follow the fuel bowser manufacturers instructions for safe use of bowser.

4. Siphon fuel from fuel tank.
5. Fit filler cap.



IGNITION COILS - SET

Service repair no - 18.20.45

Remove

1. Disconnect battery negative lead.

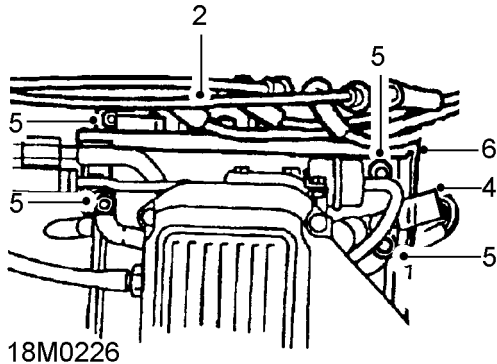

2. Noting their fitted positions, disconnect 8 h.t. leads from ignition coils.
3. Move leads aside.
4. Disconnect coil multiplug and release from mounting bracket.
5. Remove 4 nuts securing coil mounting bracket to engine.
6. Remove coils and mounting bracket assembly.
Do not carry out further dismantling if component is removed for access only.

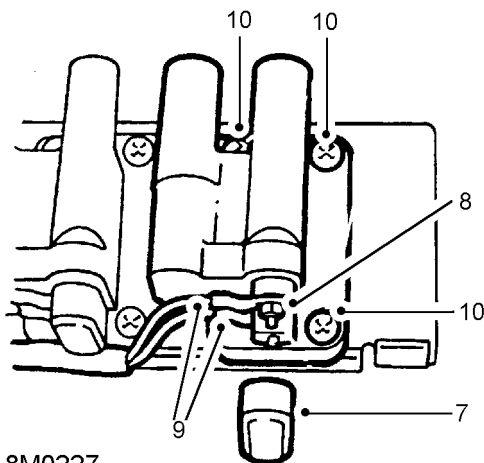

7. Remove terminal cover and note lead positions.
8. Remove 2 nuts securing leads to coil terminals.
9. Remove leads from terminals.
10. Remove 3 Torx screws securing ignition coil to mounting bracket.
11. Remove ignition coil.

12. Fit ignition coil to mounting bracket and secure with screws.
13. Fit leads to terminals and secure with nuts.

Refit

14. Position coils and mounting bracket assembly to engine.
15. Fit and tighten nuts securing mounting bracket to engine to **8 Nm, 6 lbf ft.**
16. Connect coil multiplug and secure to mounting bracket.
17. Connect h.t. leads to ignition coils.
18. Reconnect battery negative lead.

ELECTRONIC CONTROL MODULE (ECM)

Service repair no - 18.30.01

Remove

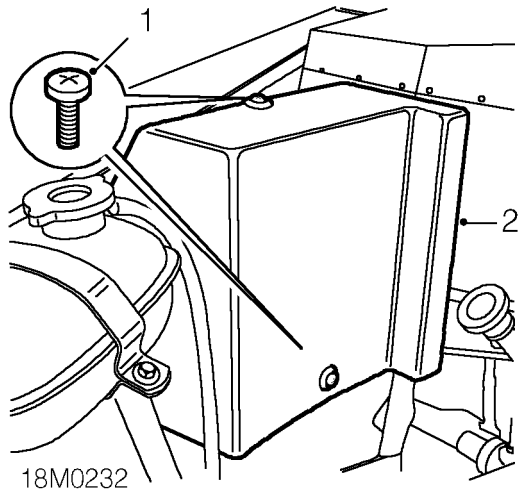

1. Remove 2 screws securing ECM cover.
2. Remove cover.

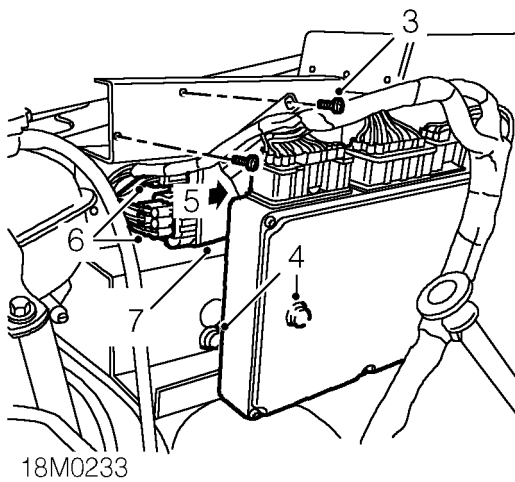

3. Disconnect 3 multiplugs from ECM.
4. Remove 2 screws securing ECM.
5. Release ECM from 2 lower retainers.
6. Remove ECM.

Refit

7. Position ECM and secure to lower retainers.
8. Fit and tighten screws securing ECM.
9. Connect multiplugs.
10. Fit cover and secure with screws.

INTAKE AIR TEMPERATURE (IAT) SENSOR

Service repair no - 18.30.09

Remove

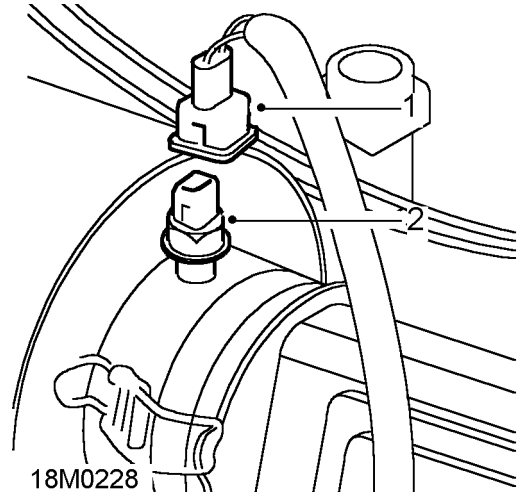

1. Disconnect multiplug from IAT sensor.
2. Remove IAT sensor from air filter housing.

Refit

3. Clean sensor and mating face on filter housing.
4. Fit sensor and tighten to **8 Nm, 6 lbf ft.**
5. Connect multiplug.



ENGINE COOLANT TEMPERATURE (ECT) SENSOR

Service repair no - 18.30.10

Remove

1. Disconnect battery negative lead.

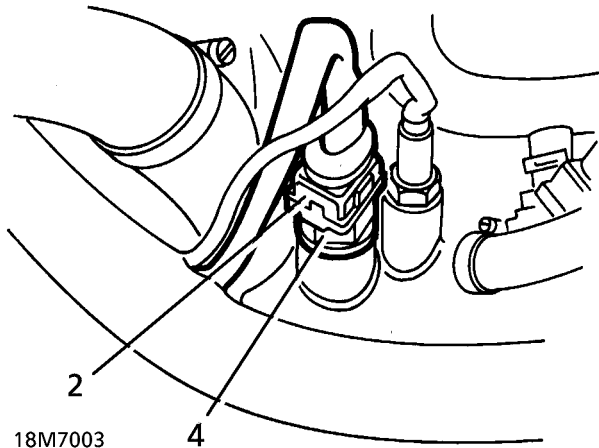

2. Depress spring clip and disconnect ECT sensor multiplug.
3. Position cloth around ECT sensor to absorb coolant spillage.
4. Remove ECT sensor.
5. Remove sealing washer and discard.

Refit

6. Clean sealing washer, sensor threads and sensor location.
7. Coat sensor threads with Loctite 577 and fit new sealing washer.
8. Fit ECT sensor and tighten to **20 Nm, 15 lbf ft.**
9. Connect multiplug to ECT sensor.
10. Top up cooling system.
11. Run engine to normal operating temperature. Check for leaks around ECT sensor.
12. Reconnect battery negative lead.

CRANKSHAFT POSITION (CKP) SENSOR

Service repair no - 18.30.12

Remove

1. Disconnect battery negative lead.
2. Raise vehicle on ramp [hoist].

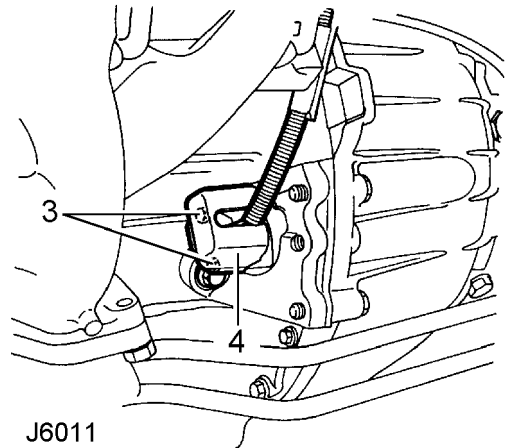

3. Remove 2 bolts securing sensor shield to engine backplate.
4. Release sensor shield.
5. Remove sensor shield.
6. Disconnect multiplug and remove sensor.
7. Remove spacer from sensor.



CAUTION: All vehicles have a spacer fitted to the sensor. Ensure spacer is correctly refitted.

Refit

8. Clean mating faces of sensor and engine backplate.
9. Fit spacer to sensor.
10. Position sensor and connect multiplug.
11. Position shield to sensor and align to engine backplate.
12. Fit bolts and tighten to **6 Nm, 4 lbf ft.**
13. Lower vehicle.
14. Reconnect battery negative lead.

CAMSHAFT POSITION (CMP) SENSOR

Service repair no - 18.30.24

Remove

1. Disconnect battery negative lead.

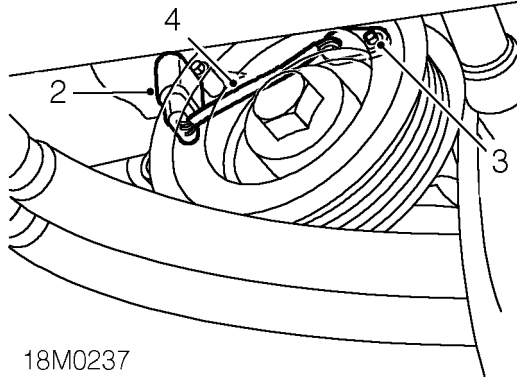

18M0237

2. Release sensor multiplug from clip and disconnect multiplug.
3. Remove bolt securing sensor to front cover.
4. Remove sensor.
5. Remove and discard 'O' ring.

Refit

6. Clean sensor and mating face on front cover.
7. Lubricate and fit 'O' ring to sensor.
8. Fit sensor, fit bolt and tighten to **8 Nm, 6lbf ft.**
9. Connect sensor multiplug and secure to bracket.
10. Reconnect battery negative lead.

KNOCK SENSOR - LH

Service repair no - 18.30.28



CAUTION: Due to the sensitivity of the sensor, do not apply tape or sealant to sensor threads.

Remove

1. Raise vehicle on ramp [hoist].

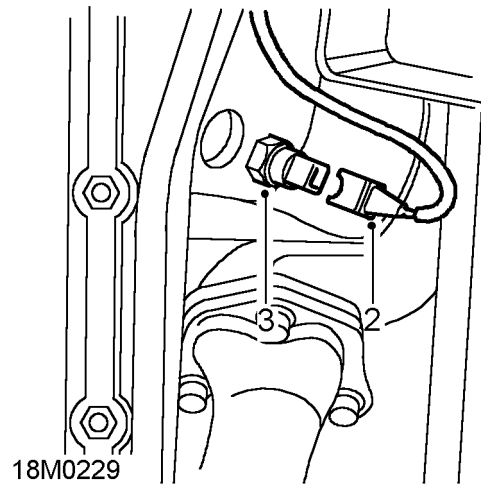

18M0229

2. Depress spring clip and disconnect multiplug from LH knock sensor.
3. Remove sensor from engine.

Refit

4. Clean mating faces of sensor and engine.
5. Fit sensor and tighten to **16 Nm, 22 lbf ft.**



CAUTION: Failure to tighten sensor to correct torque will result in malfunction or sensor damage.

6. Connect multiplug to sensor.
7. Lower vehicle.



KNOCK SENSOR - RH

Service repair no - 18.30.30



CAUTION: Due to the sensitivity of the sensor, do not apply tape or sealant to sensor threads.

Remove

1. Raise vehicle on ramp [hoist].

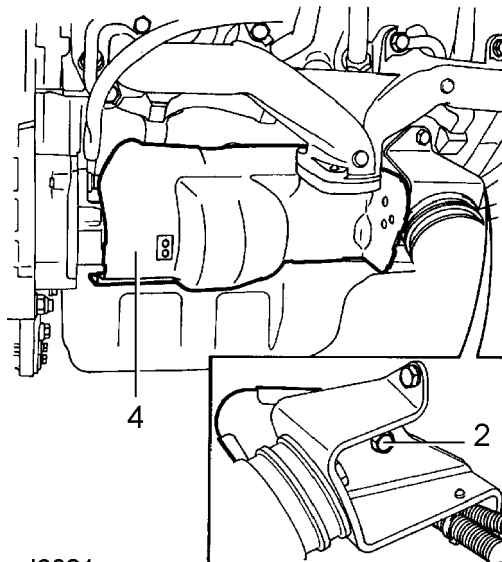

J6021

2. Remove bolt securing starter motor heat shield to engine RH mounting.
3. Release heat shield clip from starter solenoid.
4. Move heat shield aside to gain access to knock sensor.

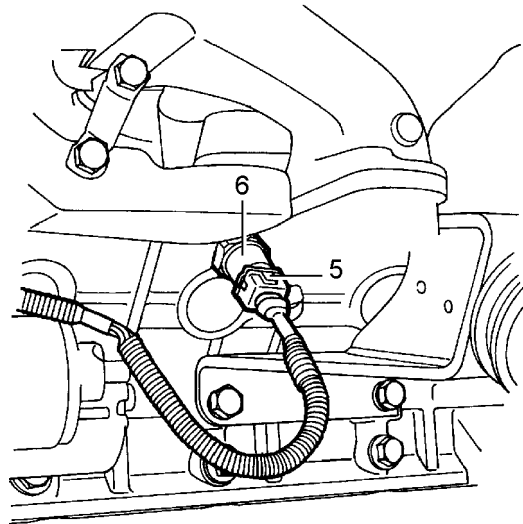

J6020

5. Depress spring clip and disconnect sensor multiplug.
6. Remove sensor.

Refit

7. Clean sensor and mating face.
8. Fit sensor and tighten to **16 Nm, 12 lbf ft.**



CAUTION: Failure to tighten sensor to correct torque will result in malfunction or sensor damage.

9. Connect multiplug to sensor.
10. Manoeuvre heat shield into position.
11. Secure heat shield clip to solenoid.
12. Align heat shield to mounting and secure with bolt.
13. Lower vehicle.

INERTIA FUEL SHUT OFF SWITCH

Service repair no - 19.22.09

Remove

1. Disconnect battery negative lead.

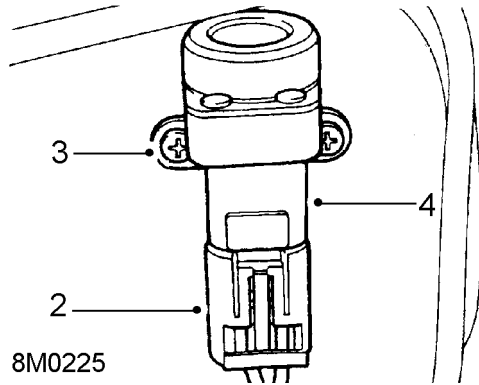

2. Disconnect multiplug from inertia fuel shut off switch.
3. Remove 2 screws securing shut off switch to mounting bracket.
4. Remove shut off switch.

Refit

5. Position fuel shut off switch to mounting bracket and secure with screws.
6. Connect multiplug to inertia switch.
7. Reconnect battery negative lead.

RELAY MODULE

Service repair no - 18.30.71

Remove

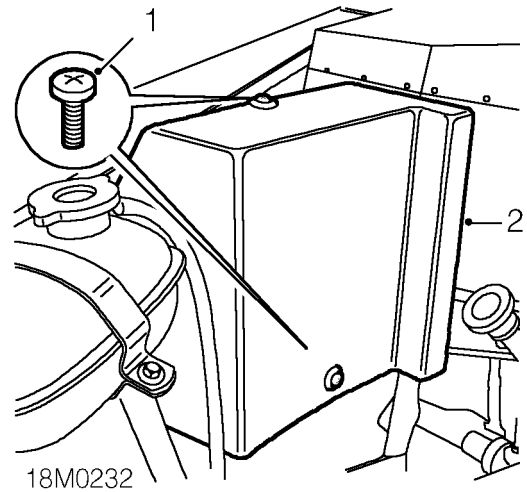

1. Remove 2 screws securing ECM cover.
2. Remove cover.

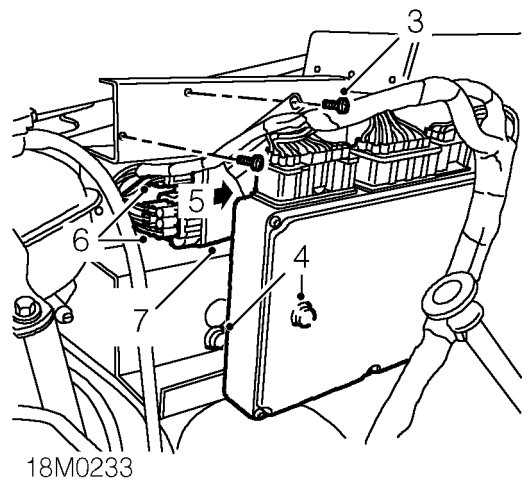

3. Remove 2 screws securing ECM.
4. Release ECM from 2 lower retainers and move aside for access to relay module.
5. Release relay module from bracket.
6. Disconnect 2 multiplugs from module.
7. Remove relay module.



Refit

8. Position relay module
9. Connect multiplugs and secure module to bracket.
10. Position ECM and secure to lower retainers.
11. Fit and tighten screws securing ECM.
12. Fit cover and tighten screws.

AIR CLEANER

Service repair no - 19.10.01

Remove

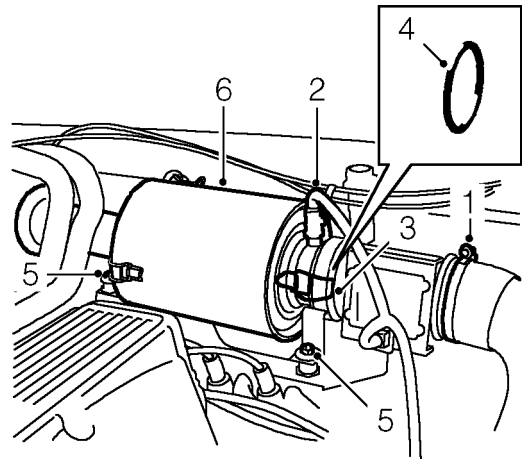

19M2349

1. Loosen clip securing intake hose to MAF sensor and disconnect hose.
2. Disconnect multiplug from IAT sensor.
3. Release 2 toggle clips and release MAF sensor from air cleaner.
4. Remove 'O' ring and carefully place sensor aside.
5. Remove 3 nuts securing air cleaner to mounting rubbers.
6. Remove air cleaner assembly.

Do not carry out further dismantling if component is removed for access only.

7. Remove IAT sensor.

Refit

8. Clean threads of IAT sensor and fit sensor to air cleaner.
9. Position air cleaner to mountings and fit and tighten nuts.
10. Clean MAF sensor and mating face.
11. Fit NEW 'O' ring, fit sensor and secure toggle clips.
12. Connect multiplug to IAT sensor.
13. Connect air intake hose and tighten clip.

19 FUEL SYSTEM

AIR CLEANER ELEMENT

Service repair no - 19.10.10

Remove

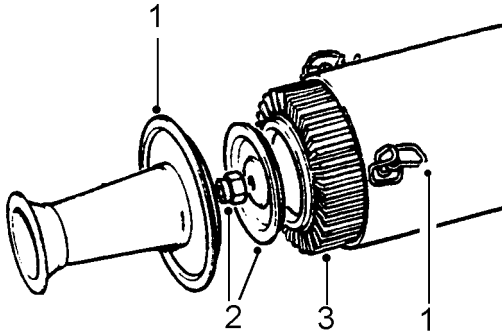

1. Release 3 toggle clips and remove inlet tube.
2. Remove nut and end plate retaining air cleaner element.
3. Remove air cleaner element and discard.

Refit

1. Clean inlet tube and inside of air cleaner.

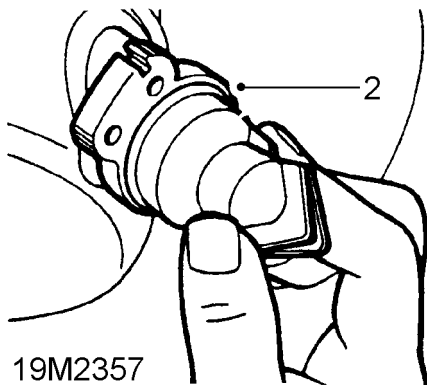

2. Squeeze open dump valve fitted at base of air cleaner and check that rubber is flexible and in good condition. Replace if necessary.
3. Fit new air cleaner element.
4. Fit retaining plate and fit and tighten nut.
5. Fit intake tube and secure toggle clips.

THROTTLE CABLE

Service repair no - 19.20.06

Remove

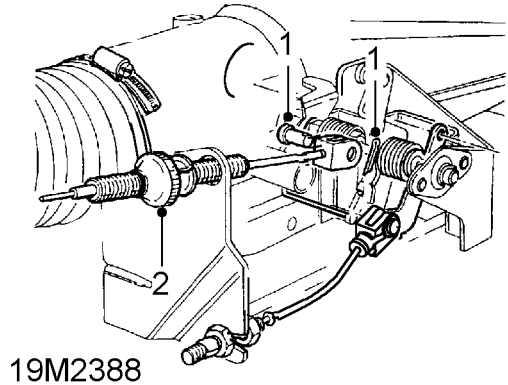

1. Remove split pin and clevis pin securing cable to throttle lever.
2. Release cable adjusting nut from abutment bracket.

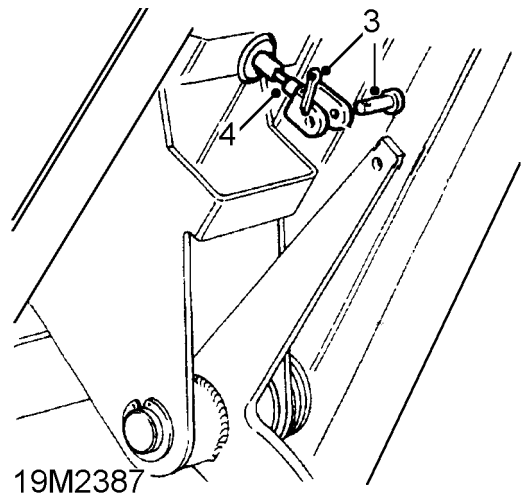

3. Remove split pin and clevis pin securing cable to throttle pedal.
4. Release cable from bulkhead and remove cable.



Refit

5. Clean area around cable hole in bulkhead.
6. Position cable and secure to bulkhead.
7. Clean and lubricate clevis pin.
8. Align inner cable to throttle pedal, fit clevis pin and secure with NEW split pin.
9. Secure outer cable to abutment bracket.
10. Clean and lubricate clevis pin.
11. Adjust outer cable and align inner cable yoke to throttle lever.
12. Fit clevis pin and secure with new split pin.
13. Adjust outer cable to give 1.6 mm, 0.06 inch of free play in inner cable.
14. Check throttle operation.

FUEL TEMPERATURE SENSOR

Service repair no - 19.22.08

Remove



NOTE: Because fuel leakage will not occur when sensor is removed, it is not necessary to depressurise the fuel system for this operation.

1. Release and move brake servo vacuum pipe aside for access to fuel temperature sensor.

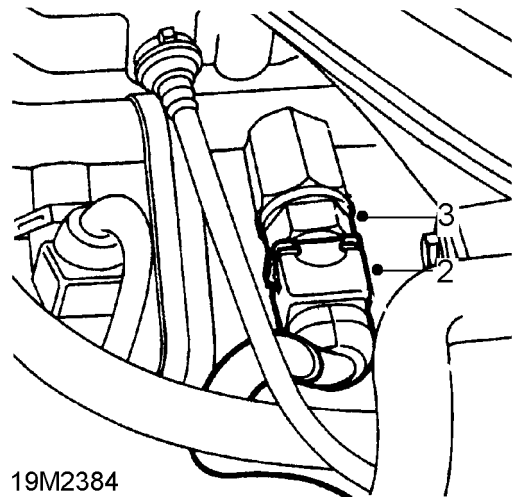

2. Disconnect multiplug from fuel temperature sensor.
3. Remove sensor.

Refit

4. Clean threads of sensor and mating face on fuel rail,
5. Fit sensor and tighten to **17Nm, 13 lbf ft.**
6. Connect multiplug and vacuum pipe.

HEATED OXYGEN SENSOR (HO2S) - FRONT

Service repair no - 19.22.16

Remove



CAUTION: The sensor must only be removed when the exhaust pipe is cold.

1. Position vehicle on ramp [hoist].
2. Remove clip securing oxygen sensor lead to harness.

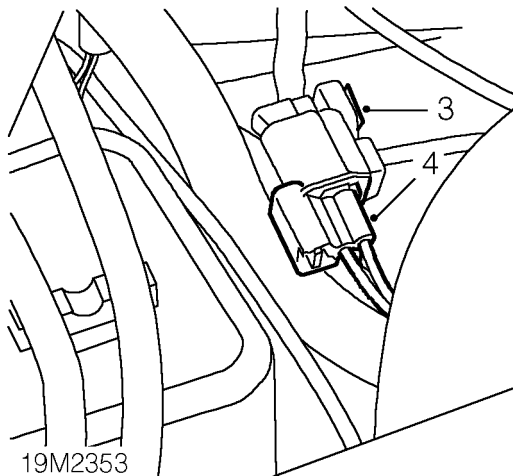

3. Release sensor multiplug from bracket behind cylinder head.
4. Disconnect multiplug.
5. Raise ramp [hoist].

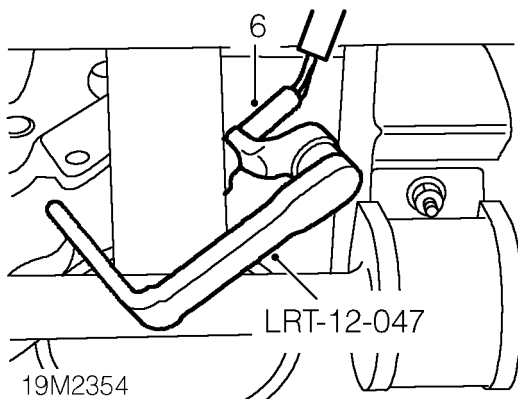

6. Remove sensor using tool **LRT-12-047**.



CAUTION: Although robust within the vehicle environment, HO2 sensors are easily damaged by dropping, excessive heat and contamination. Care must be exercised when working on the exhaust system not to damage the sensor housing or tip.

7. Remove and discard sealing washer.

Refit

8. Clean sensor mating face on exhaust pipe.



NOTE: The new sensor thread is pre-treated with an anti-seize compound. If refitting old sensor, fit **NEW sealing washer and apply anti-seize compound to threads.**



CAUTION: Do not allow anti-seize compound to come into contact with the sensor nose or enter the exhaust system.

9. Fit sealing washer to sensor and fit sensor. Tighten sensor to **20 Nm, 15 lbf ft.**
10. Lower ramp [hoist].
11. Connect multiplug and secure to bracket.
12. Secure lead to harness with clip.



HEATED OXYGEN SENSOR (HO2S) - REAR

Service repair no - 19.22.17

Remove



CAUTION: The sensor must only be removed when the exhaust pipe is cold.

1. Position vehicle on ramp [hoist].

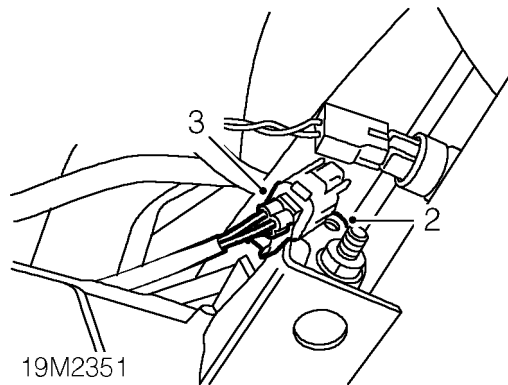

2. Release sensor multiplug from bracket.
3. Disconnect multiplug.
4. Raise ramp [hoist].

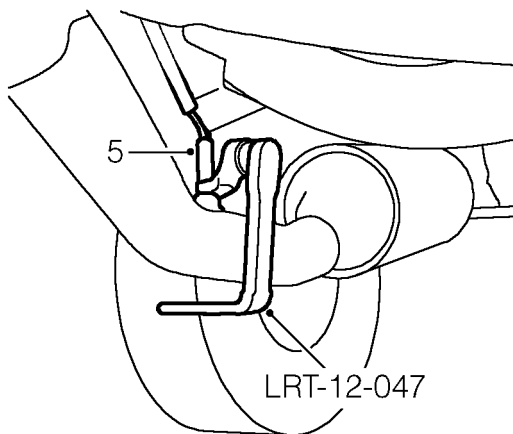

5. Remove sensor using tool **LRT-12-047**.
6. Remove and discard sealing washer.

Refit

7. Clean sensor mating face on exhaust pipe.



NOTE: The new sensor thread is pre-treated with an anti-seize compound. If refitting old sensor, fit **NEW** sealing washer and apply anti-seize compound to threads.



CAUTION: Do not allow anti-seize compound to come into contact with the sensor nose or enter the exhaust system.

8. Fit sealing washer to sensor and fit sensor. Tighten sensor to **20 Nm, 15 lbf ft.**
9. Connect multiplug and secure to bracket.
10. Lower ramp [hoist].

MASS AIR FLOW (MAF) SENSOR

Service repair no - 19.22.25

Remove

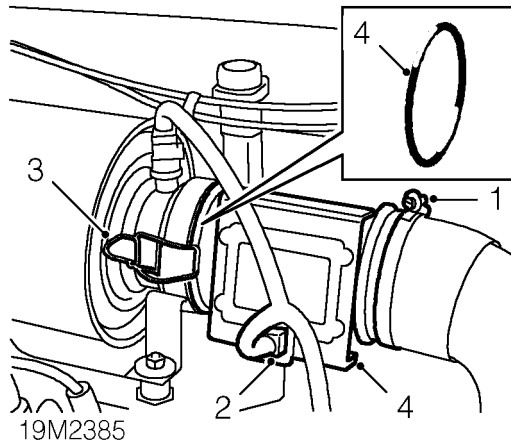

1. Loosen clip securing air intake hose to MAF sensor and disconnect.
2. Disconnect multiplug from sensor.
3. Release 2 clips securing sensor to air cleaner.
4. Remove sensor, collect and discard 'O' ring.

Refit

5. Clean sensor and mating faces.
6. Fit NEW 'O' ring to sensor.
7. Fit sensor to air cleaner and secure clips.
8. Connect multiplug.
9. Connect air intake hose to sensor and tighten clip.

PLENUM CHAMBER

Service repair no - 19.22.46

Remove

1. Disconnect battery negative lead.

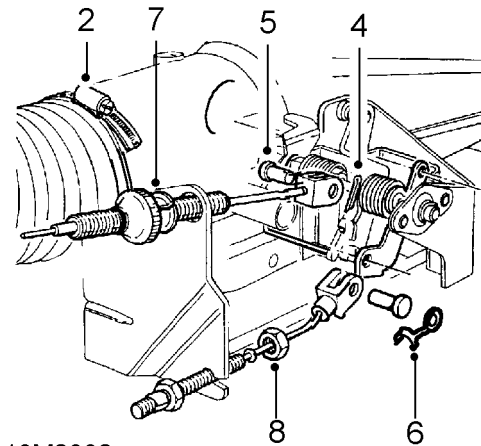

2. Loosen clip securing air intake hose to plenum chamber.
3. Disconnect air intake hose.
4. Remove split pin from throttle cable clevis pin.
5. Remove clevis pin.
6. Release and remove kick down cable clevis pin.
7. Release throttle cable from abutment bracket.
8. Remove front locknut from kick down cable.
9. Release cable from bracket.

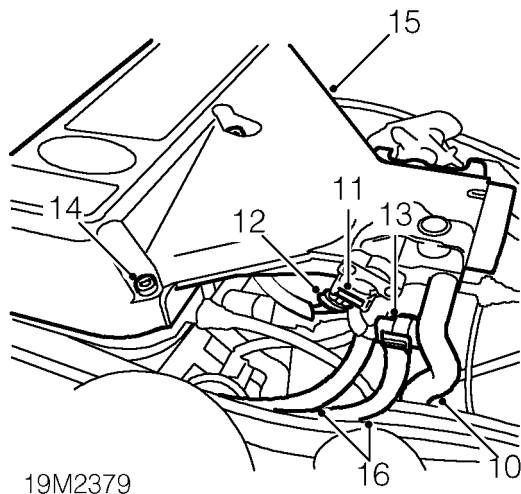

19M2379

10. Disconnect purge hose from plenum chamber.
11. Disconnect breather hose from plenum chamber.
12. Depress spring clip and disconnect TP sensor multiplug.
13. Disconnect multiplug from IACV.
14. Remove 6 bolts securing plenum chamber to inlet manifold.
15. Release plenum chamber from inlet manifold.
16. Fit hose clamp to water jacket coolant hoses.
17. Tighten clamp.
18. Position cloth to absorb coolant spillage.
19. Loosen clips securing coolant hoses to plenum chamber.
20. Release hoses from plenum chamber.
21. Remove plenum chamber.
22. Place cloth over ram housing.

Do not carry out further dismantling if component is removed for access only.

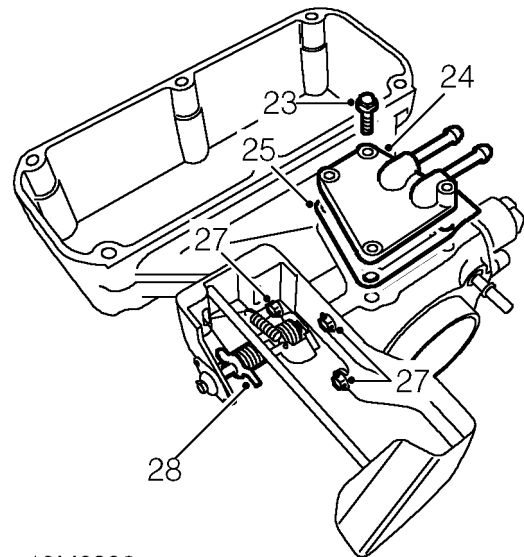

19M2380

23. Remove 4 bolts securing water jacket to plenum chamber.
24. Remove water jacket from plenum chamber.
25. Remove gasket from water jacket.
26. Move throttle linkage aside to gain access to mounting bolts.
27. Remove 3 bolts securing throttle linkage to plenum chamber.
28. Remove throttle linkage and collect spring.

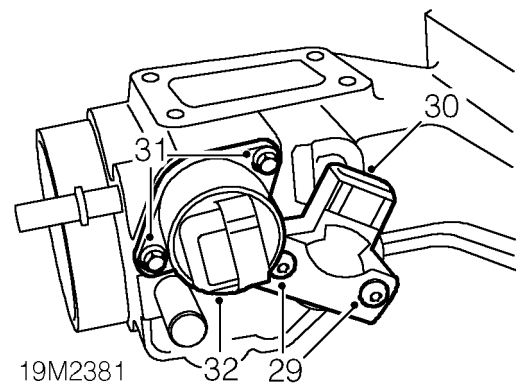

19M2381

29. Remove 2 screws securing TP sensor to plenum chamber.
30. Remove TP sensor and collect clamping plate.
31. Remove 2 bolts securing IACV to plenum chamber.
32. Remove IACV and collect gasket.

Refit

33. Position throttle linkage and spring to plenum chamber.
34. Fit spring to linkage.
35. Hold throttle open to gain access to mounting bolts.
36. Fit and tighten mounting bolts to **8 Nm, 6 lbf ft.**
37. Clean mating faces of TP sensor and plenum chamber.
38. Fit TP sensor and engage spindle.
39. Fit clamping plate and tighten bolts to **2 Nm, 1.5 lbf ft.**
40. Clean mating faces of IACV and plenum chamber.
41. Fit gasket to IACV.
42. Fit IACV to plenum chamber and tighten bolts to **2 Nm, 1.5 lbf ft.**
43. Clean mating faces of water jacket and plenum chamber.
44. Position gasket to plenum chamber.
45. Fit water jacket to plenum chamber and tighten bolts to **13 Nm, 10 lbf ft.**
46. Remove cloth from ram housing.
47. Clean plenum and inlet manifold mating faces.
48. Position plenum chamber.
49. Connect coolant hoses to plenum chamber.
50. Tighten hose clips.
51. Loosen and remove hose clamp.
52. Remove cloth.
53. Apply a thin, uniform coating of Loctite 577 sealant to sealing face of plenum chamber.
54. Fit plenum chamber and tighten bolts to **24 Nm, 18 lbf ft.**
55. Connect multiplug to TP sensor.
56. Connect multiplug to IACV.
57. Connect breather hose to plenum chamber.
58. Connect purge hose to plenum chamber.
59. Fit kick down cable to abutment bracket, fit locknut and adjust cable. **See AUTOMATIC GEARBOX, Adjustment, Kickdown cable adjustment**
60. Connect throttle cable to abutment bracket.
61. Align throttle cable to lever, fit clevis pin and secure with new split pin.
62. Align kick down cable to lever.
63. Fit and secure clevis pin.
64. Connect air intake hose and secure with clip.
65. Reconnect battery negative lead.
66. Top up cooling system.

THROTTLE POSITION (TP) SENSOR

Service repair no - 19.22.49

Remove

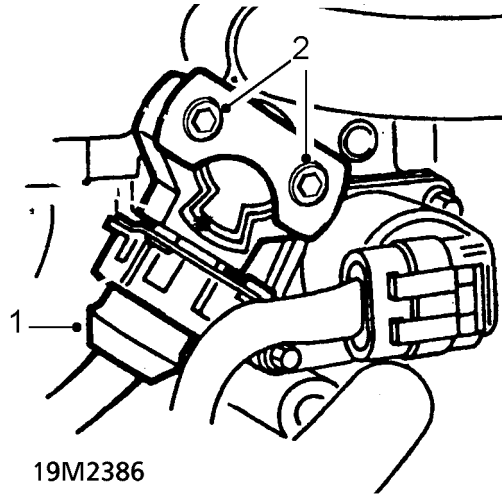

1. Disconnect multiplug from TP sensor.
2. Remove 2 screws securing TP sensor and collect clamp plate.
3. Remove TP sensor.

Remove

4. Clean TP sensor and mating face.
5. Fit sensor ensuring drive engages with throttle spindle.
6. Position clamp plate, fit screws and tighten to **2 Nm, 1.5 lbf ft.**
7. Connect multiplug.



IDLE AIR CONTROL VALVE (IACV)

Service repair no - 19.22.54

Remove

1. Disconnect battery negative lead.

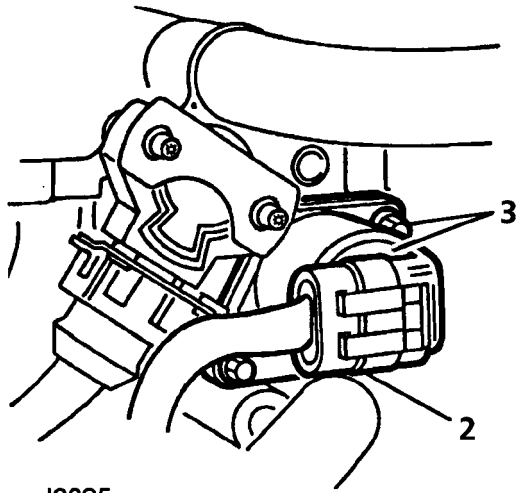

J6025

2. Disconnect multiplug from IACV.
3. Remove 2 bolts securing IACV to plenum chamber.
4. Remove IACV.
5. Remove gasket and discard.

Refit

6. Clean mating faces of IACV and plenum chamber.
7. Clean plunger on IACV and plunger seat on plenum chamber.
8. Using a new gasket, fit IACV to plenum chamber.
9. Fit and tighten bolts securing IACV to plenum chamber to **2 Nm, 1.5 lbf ft.**
10. Connect multiplug to IACV.
11. Reconnect battery negative lead.

FUEL FILTER

Service repair no - 19.25.02



WARNING: Spilling of fuel is unavoidable during this operation. Ensure all necessary precautions are taken to prevent fire and explosion.



WARNING: Ensure fuel handling precautions given in Section 01 - Introduction are strictly adhered to when carrying out the following instructions.

Remove

1. Depressurise fuel system. *See Adjustment, fuel system depressurise*
2. Clean area around hose connections to prevent ingress of dirt into fuel system.

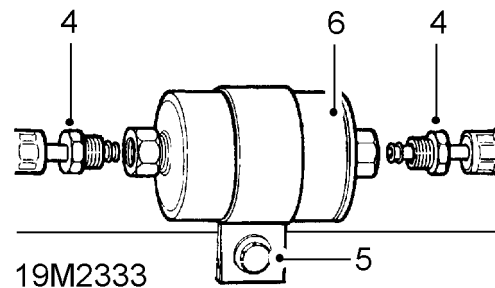

19M2333

3. Clamp inlet and outlet hoses to reduce fuel spillage when disconnecting.
4. Loosen 2 unions and disconnect hoses from fuel filter.



CAUTION: Plug the connections.

5. Loosen bolt securing fuel filter to chassis member.
6. Remove fuel filter.

Refit

7. Position NEW filter to chassis member, observing direction of flow arrow stamped on side.
8. Tighten bolt securing filter to chassis member.
9. Remove plugs.
10. Connect hoses to fuel filter and tighten unions to **30 Nm, 22 lbf ft.**
11. Remove clamps from hoses.
12. Start engine and inspect for fuel leaks.

FUEL PRESSURE REGULATOR

Service repair no - 19.45.06

Remove

1. Disconnect battery negative lead.
2. Depressurise fuel system. **See Adjustment, fuel system depressurise**

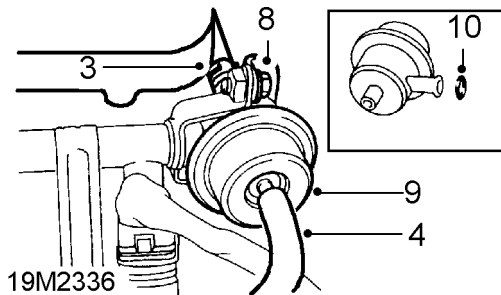

3. Release clip and disconnect fuel return hose from fuel pipe.



CAUTION: Plug the connections.

4. Disconnect vacuum hose from pressure regulator.
5. Remove 4 nuts securing coil mounting bracket to inlet manifold.
6. Release coil mounting bracket from studs and move aside.
7. Release regulator connecting pipe from clip.
8. Remove 2 bolts securing pressure regulator to fuel rail.
9. Remove regulator from fuel rail.
10. Remove and discard 'O' ring.
11. Release clip and remove fuel hose from regulator.



CAUTION: Plug the connections.

Refit

12. Clean mating faces of pressure regulator and fuel rail.
13. Remove plugs from pressure regulator and fuel rail.
14. Fit fuel hose to regulator and secure with clip.
15. Lubricate new pressure regulator 'O' ring.
16. Fit regulator to fuel rail.
17. Connect fuel hose to pipe and secure with clip.
18. Fit bolts securing regulator to fuel rail and tighten to **10 Nm, 7 lbf ft.**
19. Position ignition coil mounting bracket to studs.
20. Fit nuts and tighten to **8 Nm, 6 lbf ft.**
21. Remove plugs.
22. Connect fuel return hose and secure with clip.
23. Connect vacuum hose.
24. Remove cloth.
25. Reconnect battery negative lead.



FUEL PUMP

Service repair no - 19.45.08

Remove

1. Disconnect battery negative lead.
2. Remove fuel tank. **See fuel tank**

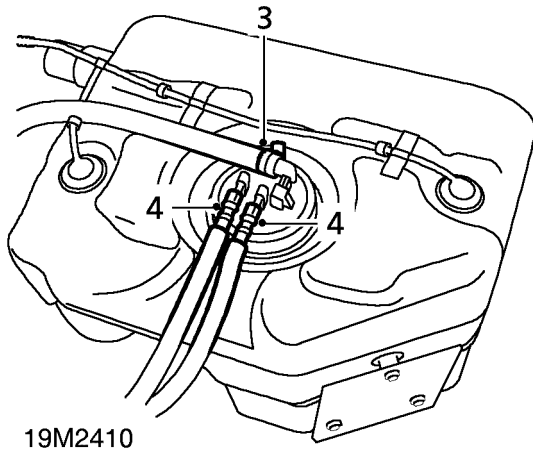

3. Loosen clip and disconnect breather hose from fuel pump.
4. Remove fuel feed and return hoses from fuel pump.

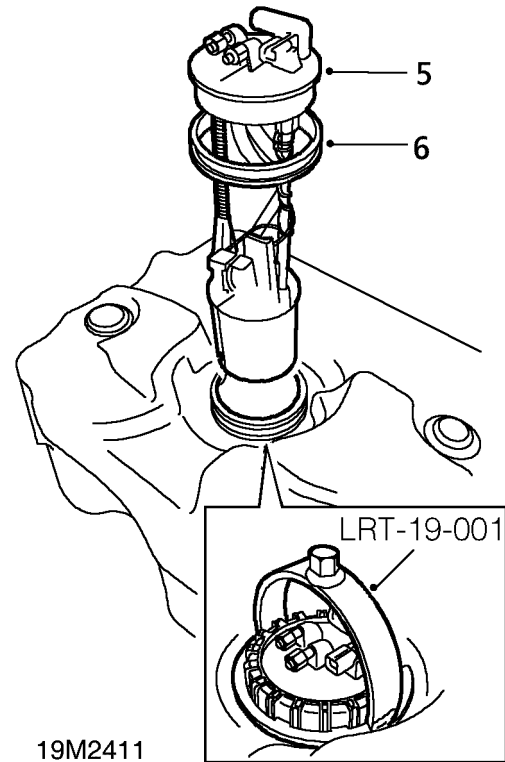

5. Using tool **LRT-19-001** remove locking ring securing pump. Withdraw fuel pump from fuel tank.



WARNING: A quantity of fuel will be retained in body of pump. Care must be taken to prevent spillage during above operation.

6. Remove and discard sealing ring.

Refit

7. Fit new sealing ring to pump and fit pump.
8. Fit locking ring and using tool **LRT-19-001**, tighten to **48 Nm, 35 lbf ft.**
9. Fit feed and return hoses to pump.
10. Fit breather hose and tighten clip.
11. Fit fuel tank. **See fuel tank; Refit**

FUEL TANK

Service repair no - 19.55.26



WARNING: Ensure that fuel handling precautions given in Section 01 - Introduction are strictly adhered to when carrying out following instructions.



CAUTION: Before disconnecting any part of the fuel system, it is imperative that all dust, dirt and debris is removed from around components to prevent ingress of foreign matter into fuel system.

Remove

1. Position vehicle on ramp [hoist].
2. Disconnect battery negative lead.
3. Depressurise fuel system. **See Adjustment, fuel system depressurise**
4. Drain fuel tank. **See Adjustment, fuel tank drain**

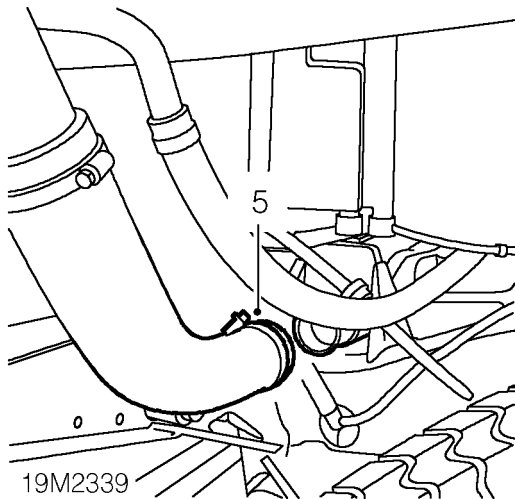

5. Loosen clip securing filler hose to fuel tank and disconnect hose.

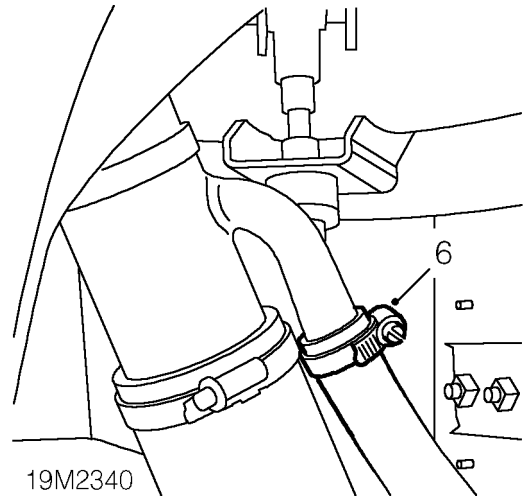

6. Loosen clip securing breather hose to filler neck and disconnect hose.

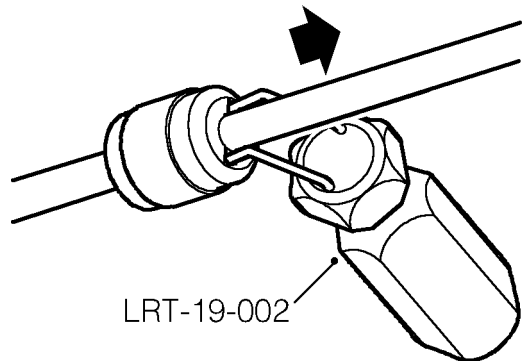

7. Using tool **LRT-19-002** disconnect vapour separator pipe at green end of 'speedfit' connector.
8. Position cloth to absorb fuel spillage.

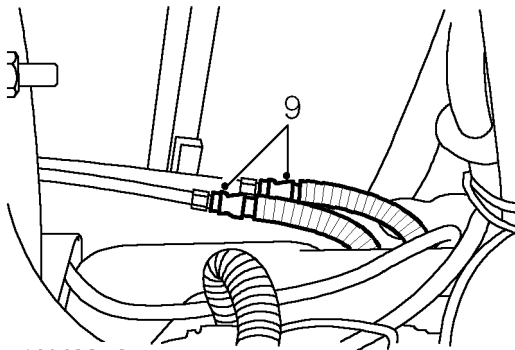

19M2342

9. Disconnect fuel feed hose union.
10. Disconnect fuel return hose union.



CAUTION: Plug the connections.

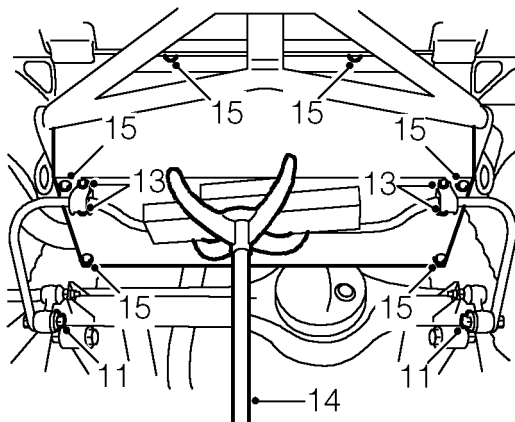

19M2343

11. Loosen 2 anti-roll [sway] bar link bolts.
12. Mark location of anti-roll [sway] bar straps.
13. Remove 4 bolts securing anti-roll [sway] bar straps and swing bar down clear of fuel tank.
14. Position transmission jack under fuel tank cradle to support fuel tank.



CAUTION: Use a block of wood or hard rubber pad to protect fuel tank.

15. Remove 6 bolts securing fuel tank cradle.
16. Lower fuel tank sufficiently to gain access to fuel pump multiplug.

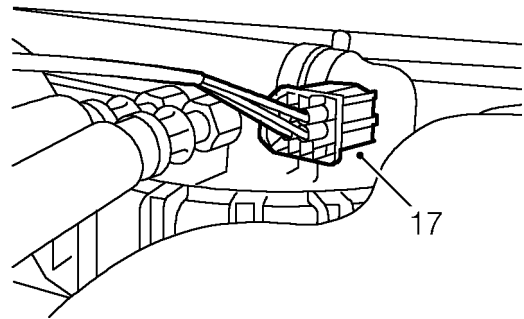

19M2344

17. Disconnect multiplug and remove clip securing harness to fuel hoses.
18. With assistance, lower jack, remove fuel tank cradle and fuel tank.

Do not carry out further dismantling if component is removed for access only.

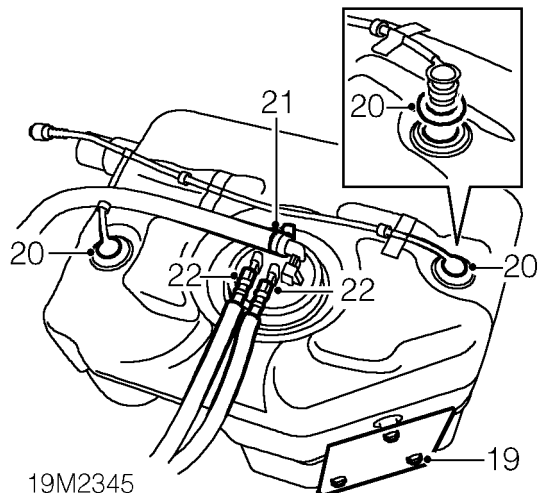

19M2345

19. Remove 3 screws securing heat shield. Remove heat shield.
20. Release 2 fuel cut-off valves and remove valve and pipe assembly. Remove and discard 2 rubber seals.
21. Loosen clip and remove breather hose from fuel pump.
22. Remove fuel feed and return hoses from fuel pump.

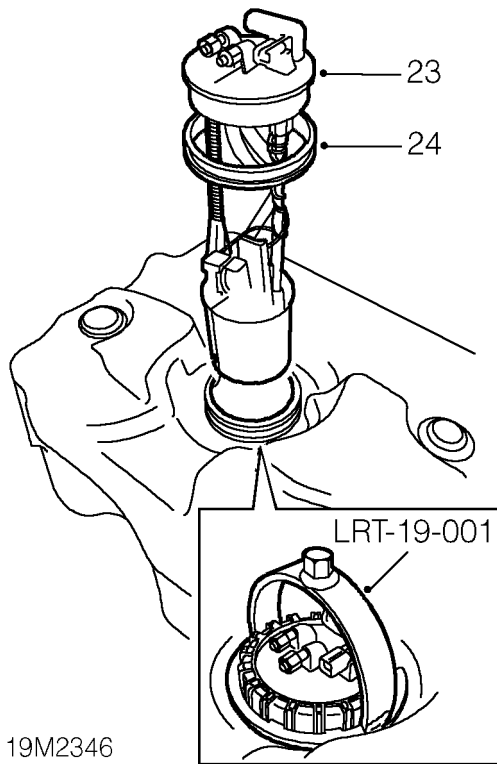

19M2346

23. Using tool **LRT-19-001** remove locking ring securing pump. Withdraw fuel pump from tank.



WARNING: A quantity of fuel will be retained in body of pump. Care must be taken to prevent fuel spillage during above operation.

24. Remove and discard sealing ring.
25. Fit new sealing ring to pump and fit pump.
26. Fit locking ring and using tool **LRT-19-001**, tighten to **48 Nm, 35 lbf ft.**
27. Fit fuel feed and return hoses to pump.
28. Fit breather hose and tighten clip.
29. Fit new fuel cut-off valve seals.
30. Fit valve and pipe assembly.
31. Fit heat shield.

Refit

32. With assistance, locate fuel tank and position cradle.
33. Position jack to support tank.
34. Connect fuel pump multiplug.
35. Raise jack, align cradle and fit and tighten bolts.
36. Raise anti-roll [sway] bar, align straps and fit and tighten bolts.
37. Tighten anti-roll [sway] bar link bolts
38. Clean fuel pipes, connect pipes and tighten unions.
39. Secure harness to fuel pipes with clip.
40. Connect vapour separator pipe.
41. Connect breather hose to filler neck and tighten hose clip.
42. Connect filler hose to fuel tank and tighten hose clip.
43. Reconnect battery negative lead.
44. Run engine and check for leaks.



FUEL RAIL

Service repair no - 19.60.04

Remove

1. Disconnect battery negative lead.
2. Depressurise fuel system. **See Adjustment, fuel system depressurise**
3. Remove ram housing. **See ram housing**

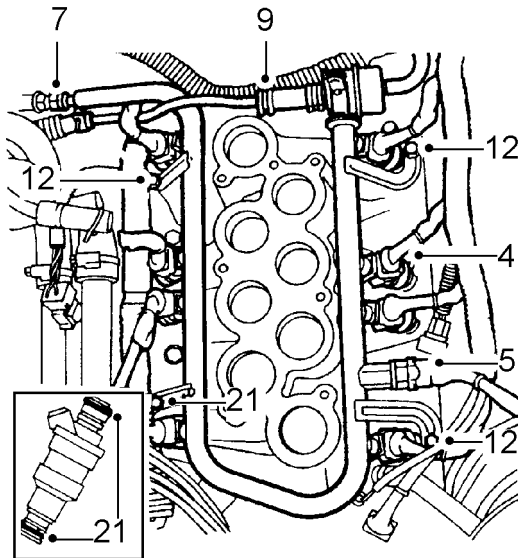

19M2338

4. Disconnect 8 injector multiplugs.
5. Disconnect fuel temperature sensor multiplug.
6. Position cloth around fuel feed pipe union to absorb any fuel spillage.
7. Disconnect fuel feed pipe from fuel rail.
8. Plug fuel pipe and rail.
9. Loosen clip securing fuel return hose to fuel rail and disconnect hose.
10. Plug hose and rail.
11. Remove cloth.
12. Remove 6 nuts securing fuel rail and ignition coil mounting bracket to inlet manifold.
13. Release ignition coil mounting bracket from inlet manifold studs and move aside.
14. Release fuel rail and injectors from inlet manifold.
15. Remove fuel rail and injectors.

Do not carry out further dismantling if component is removed for access only.

16. Remove 2 bolts securing regulator to fuel rail.
17. Remove regulator.
18. Remove and discard 'O' ring.
19. Remove 8 clips securing injectors to fuel rail.
20. Remove injectors from fuel rail.
21. Remove and discard 'O' rings from injectors.
22. Clean lower mating faces on ram housing and manifold.
23. Lubricate new 'O' rings.
24. Fit NEW 'O' rings to injectors. Lightly coat 'O' rings with silicone grease.
25. Fit injectors to fuel rail.
26. Fit clips securing injectors to fuel rail.



CAUTION: Care must be taken when refitting the fuel rail and injectors to inlet manifold to prevent damage to 'O' rings.

27. Lubricate NEW 'O' ring of fuel regulator with silicone grease.
28. Fit 'O' ring.
29. Fit regulator to fuel rail and tighten bolts to **10 Nm, 7 lbf ft.**

Refit

30. Position fuel rail.
31. Secure fuel rail.
32. Position coil bracket.
33. Fit nuts securing coil bracket and fuel rail and tighten to **8 Nm, 6 lbf ft.**
34. Remove plugs from fuel feed and return pipes and fuel rail.
35. Connect return hose and secure with clip.
36. Clean feed pipe union.
37. Connect fuel feed pipe and tighten union to **16 Nm, 11 lbf ft.**
38. Connect injector and fuel temperature sensor multiplugs.
39. Fit ram housing. **See ram housing; Refit**
40. Reconnect battery negative lead.

RAM HOUSING

Service repair no - 19.70.04

Remove

1. Disconnect battery negative lead.
2. Remove plenum chamber. *See plenum chamber*

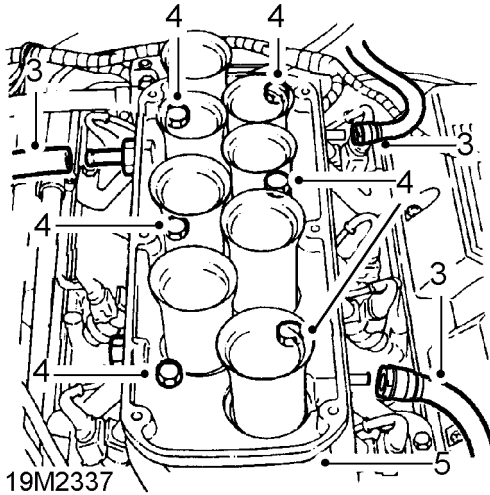

3. Disconnect 3 hoses from ram housing.
4. Remove 6 bolts securing ram housing to inlet manifold.
5. Using a suitable lever and a block of wood, release ram housing from inlet manifold. Remove ram housing.



CAUTION: Do not use a mallet to break sealant joint with inlet manifold.

6. Place a protective cover over inlet bores to prevent ingress of dirt.

Refit

7. Clean mating faces of inlet manifold and ram housing.
8. Apply 'Hylomar' sealant to inlet manifold face.
9. Fit ram housing to inlet manifold.



NOTE: The ram housing can be fitted the wrong way round. Ensure fuel pressure regulator hose connection is on correct side when refitting.

10. Tighten ram housing bolts, working from 2 centre bolts, diagonally towards 4 outer bolts to **24 Nm, 18 lbf ft.**
11. Connect hoses to ram housing.
12. Fit plenum chamber. *See plenum chamber; Refit*
13. Reconnect battery negative lead.



WHEEL SPEED SENSOR - FRONT

Service repair no - 19.80.01

Remove



CAUTION: If a sensor is removed for any reason, a **NEW** sensor bush and seal must be fitted.

1. Disconnect battery negative lead.

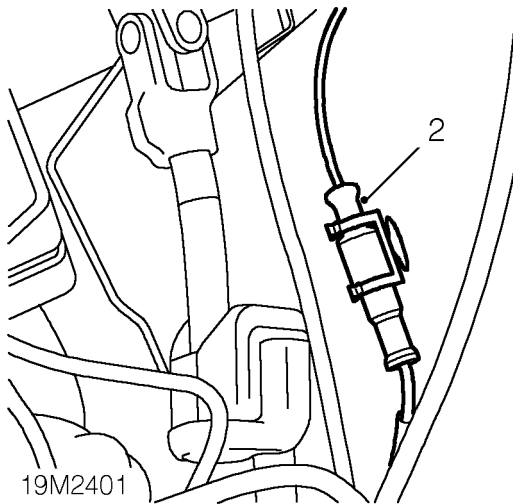

2. Release wheel speed sensor multiplug from clip on inner wing [fender] and disconnect.
3. Raise vehicle on 4 post ramp.
4. Release cable ties securing sensor harness to chassis and front axle.
5. Clean area around sensor to prevent possible ingress of dirt.
6. Using a suitable lever, release sensor from mounting bush.
7. Remove sensor.
8. Position container to collect any brake fluid.
9. Clamp flexible brake hose to caliper.
10. Using 2 spanners, loosen brake pipe to hose union and disconnect.



CAUTION: Do not allow brake fluid to contact paint finished surfaces as paint may be damaged. If spilled, remove fluid and clean area with clean warm water.

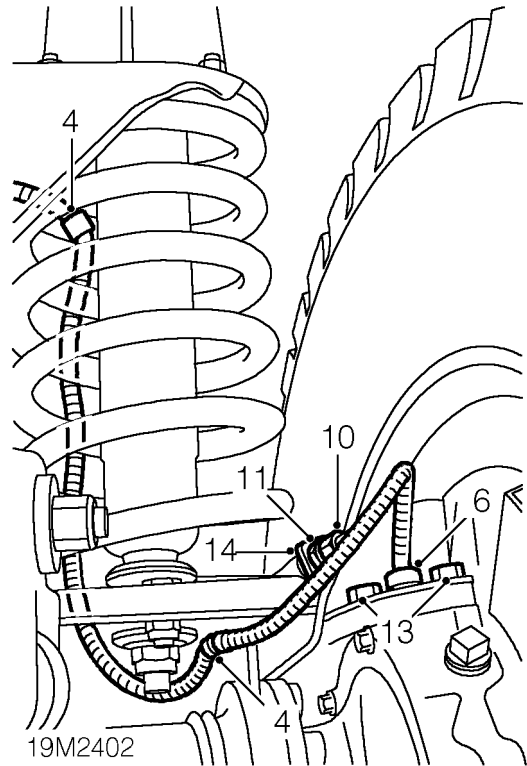

11. Remove nut securing brake pipe to mounting bracket.
12. Release brake hose from mounting bracket.
13. Remove 2 bolts securing bush retaining plate to top of hub.
14. Release retaining plate from mud shield and remove.
15. Remove and discard seal and bush from hub.

Refit

16. Ensure sensor bush and seal mating faces are clean.
17. Fit sensor bush and seal to hub.
18. Fit retaining plate to hub and secure with bolts.



CAUTION: Apply Loctite 270 to retaining plate bolts.

19. Position brake hose to mounting bracket and secure with nut.
20. Connect brake pipe to hose and, using 2 spanners, tighten union.
21. Remove clamp from brake hose.
22. Ensure sensor body is clean and coat with EP 90 oil.
23. Fit sensor through bush until it contacts the reluctor ring. The sensor will be 'knocked-back' to the correct position when the vehicle is driven.
24. Route sensor lead up through engine compartment and secure cable ties.
25. Lower vehicle.
26. Connect sensor multiplug and secure to clip.
27. Reconnect battery negative lead.
28. Bleed brake system. **See BRAKES, Repair, brake system bleed**

WHEEL SPEED SENSOR - REAR

Service repair no - 19.80.02

Remove



CAUTION: If a sensor is removed for any reason, a **NEW** sensor bush and seal must be fitted.

1. Disconnect battery negative lead.
2. Raise rear of vehicle.



WARNING: Support on safety stands.

3. Remove both rear road wheels.

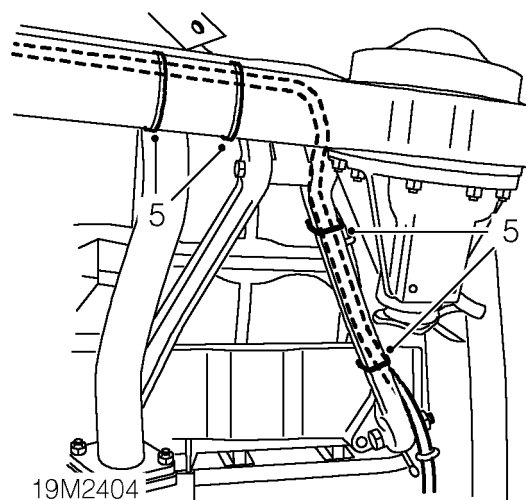
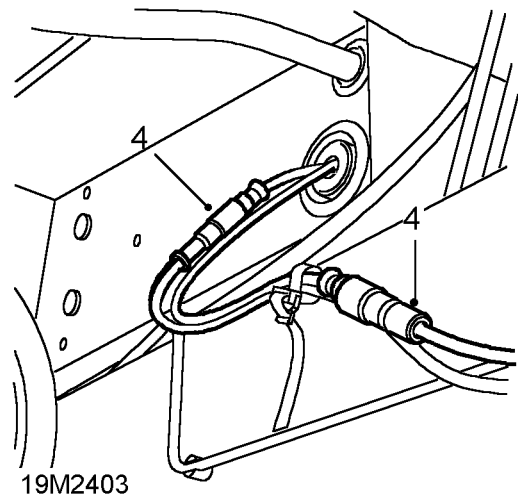

4. Disconnect sensor multiplugs at RH side of chassis.
5. Release cable ties securing sensor harness to rear suspension and axles.

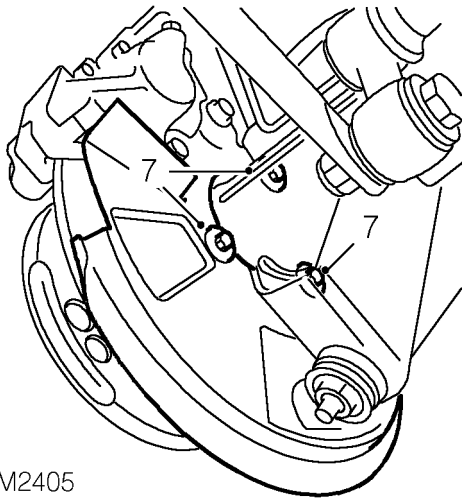

19M2405

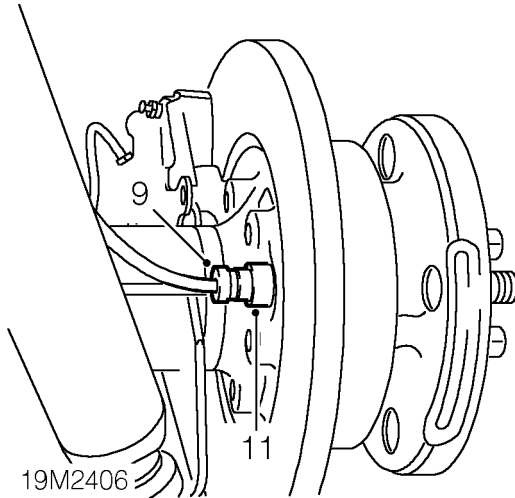

19M2406

Refit

12. Ensure NEW sensor bushes and housings are clean, then fit bushes.
13. Ensure sensor bodies are clean and lightly coat with EP 90 lubricant.
14. Fit sensors through bushes until they contact the reluctor ring. The sensors will be 'knocked-back' to the correct position when the vehicle is driven.
15. Secure sensor harness to rear axle clips.
16. Secure sensor harness to rear suspension and axle with cable ties.
17. Connect sensor harness multiplugs.
18. Position rear brake caliper mud shields and secure with bolts.
19. Fit rear road wheels.
20. Remove stand(s) and lower vehicle.
21. Reconnect battery negative lead.

6. Release sensor harness from clips on rear axle.
7. Remove 6 bolts, 3 each side, securing rear wheel brake caliper mud shields.
8. Remove mud shields and clear area around sensor to prevent possible ingress of dirt.
9. Using a suitable lever, release sensors from mounting bushes.
10. Remove sensors.
11. Remove and discard sensor bushes.

ECU - ROUGH ROAD DETECTION

Service repair no - 19.80.03

Remove

1. Disconnect battery negative lead.

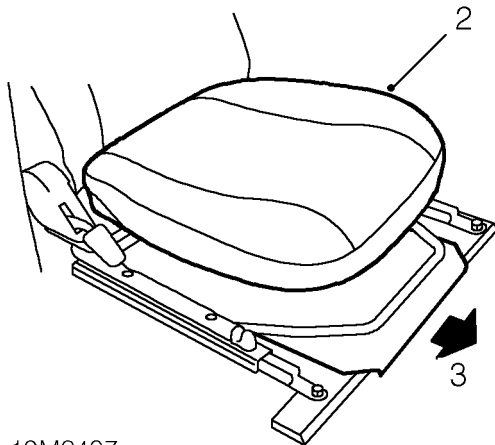

2. Release front edge of passenger seat cushion and remove cushion.
3. Release clip and remove ECU cover plate.

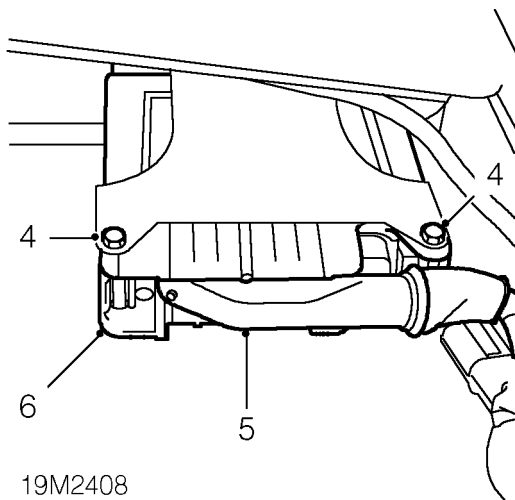

4. Remove 2 bolts securing ECU to mounting bracket and collect nuts.
5. Remove ECU from mounting bracket and disconnect multiplug.
6. Remove ECU.

Refit

7. Fit ECU, connect multiplug and position to mounting bracket.
8. Secure ECU mounting bracket with nuts and bolts.
9. Fit ECU cover plate and secure with clip.
10. Position rear edge of passenger seat cushion to seat frame and secure front edge to clips.
11. Reconnect battery negative lead.



TORQUE SETTINGS

	Nm	lbf ft
Intake air temperature (IAT) sensor	8	6
Crank position sensor	8	6
Coolant temperature sensor	20	15
Fuel filter	30	20
Fuel pressure regulator	10	7
Coil bracket	8	6
Fuel feed pipe	16	12
Ram housing to manifold	24	18
Fuel temperature sensor	17	13
Throttle position sensor	2	1.5
Knock sensor	16	12
Idle air control valve	2	1.5
Water jacket	13	10
Throttle bracket	8	6
Plenum chamber	24	18
Inlet manifold	38	28
Camshaft position sensor	8	6
Heated oxygen sensors	20	15
Fuel pump locking ring	48	35



ENGINE COOLING

Description

The V8i engine uses a pressurised cooling system and cross flow radiator which is supplied from a separate expansion tank. The coolant radiator also incorporates a section at the side for cooling the engine oil. The transmission fluid cooler is mounted below the radiator.

The belt driven viscous fan and centrifugal water pump is located in the engine front cover with ports for circulation of coolant to both banks of cylinders and cylinder heads. Coolant returns to the top of the radiator via ports in the inlet manifold where the thermostat is mounted horizontally.

Coolant also circulates through the vehicle heating system and is used to heat air entering the inlet manifold plenum chamber.

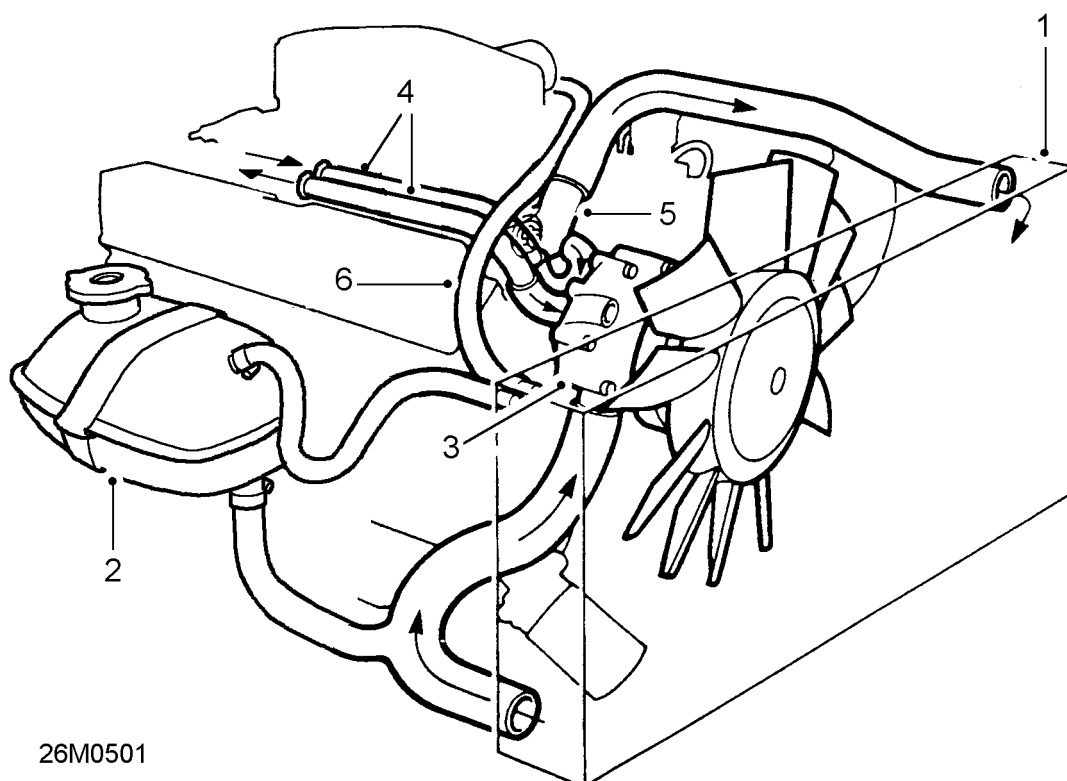

26M0501

Coolant circulation (engine hot)

1. Cross flow radiator
2. Expansion tank
3. Viscous fan and water pump
4. Heater pipes
5. Thermostat
6. Plenum chamber connection

COOLANT CIRCULATION

Operation

When the engine is started from cold the thermostat prevents any coolant circulation through the radiator by closing off the top hose. During the engine warm up period, the water pump, pumps coolant around the cylinders to the rear of the cylinder block along the main galleries in both cylinder banks. At the rear of the cylinder block the coolant rises through a large port in each cylinder head/block joint face, and then flows forward to connect with ports at the front of the inlet manifold. From the manifold the coolant is carried by an external pipe to the heater unit and from the heater through another external pipe to the pump inlet.

The coolant circulation through the cylinder block and heads, does not change when normal running temperature is reached and the thermostat opens. But with the thermostat open, coolant also flows through the top hose to the radiator where it is cooled and drawn back into the pump via the bottom hose.

Throttle housing heating

The base of the throttle housing is heated by a flow of coolant from the inlet manifold which returns through a long hose, to the top right corner of the radiator. The throttle housing is heated to prevent throttle disc icing.

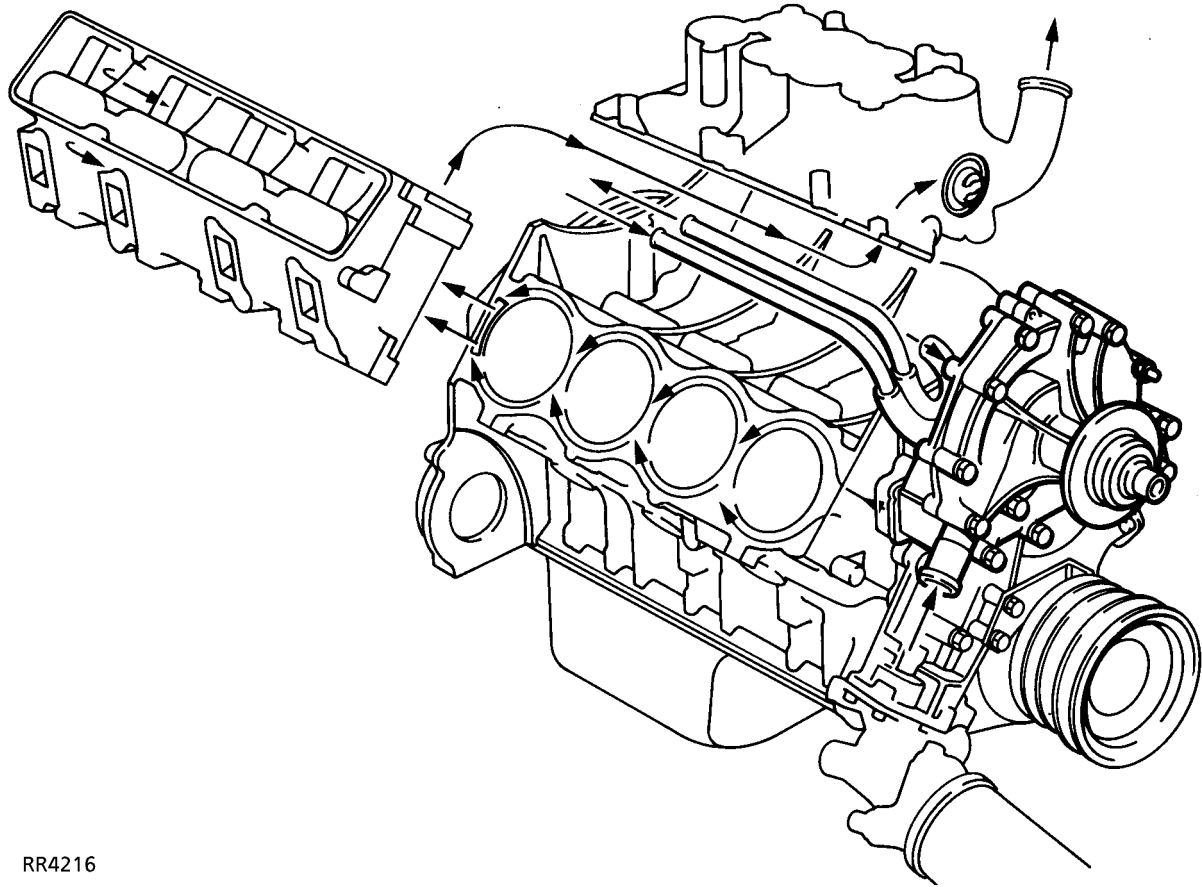

RR4216



VISCOUS FAN

Description

The viscous drive unit for the engine cooling fan, provides a means of controlling the speed of the fan relative to the running temperature of the engine. The viscous unit is a type of fluid coupling, which drives the fan blades by means of 'silicone fluid'.

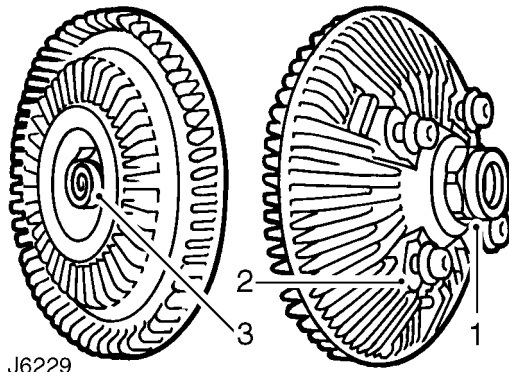

- 1. Input (drive) member
- 2. Output (driven) member
- 3. Sensing mechanism (bi-metal coil)

The fan drive has to be engaged only periodically, between 5% and 10%, during normal operating conditions, because the engine is cooled by ram air for most of the time.

Operation

To engage and disengage the fan drive the bi-metal coil senses air temperature behind the radiator. When a pre-determined temperature is reached, the coil opens a valve (5) which allows fluid to enter the drive area and, due to centrifugal force, circulates to the annular drive area.

There are two sets of annular grooves (3), one in the drive clutch and the other in the drive body, a specific clearance being provided between the two sets of grooves.

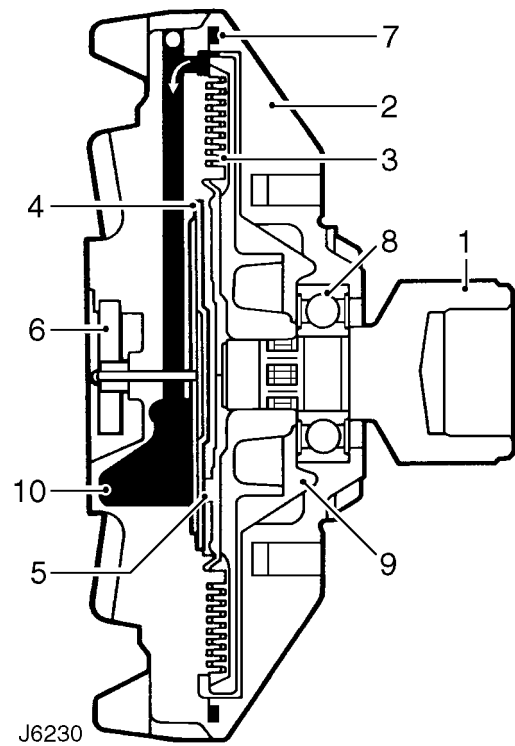

Viscous unit disengaged (engine at normal running temperature)

- 1. Input (drive) member
- 2. Output (driven) member
- 3. Running clearance
- 4. Pump plate
- 5. Valve (closed)
- 6. Sensing mechanism (bi-metal coil)
- 7. Fluid seal
- 8. Bearing, input member
- 9. Fluid chamber
- 10. Fluid reservoir

When this clearance is filled with viscous fluid, a shearing action, caused by the speed differential between the two drive components, transmits torque to the fan. The fluid is thrown to the outside of the unit by centrifugal force from where it is recirculated to the reservoir (10) via the pump plate (4) adjacent to the drive member.

If the engine speed is increased the amount of slip will also increase to limit the maximum fan speed.

When the air temperature from the radiator drops sufficiently, the bi-metal coil closes the valve and prevents fluid entering the drive area. The fluid that is in the drive area will gradually pump out into the reservoir (10) and the fan will return to an idle condition.

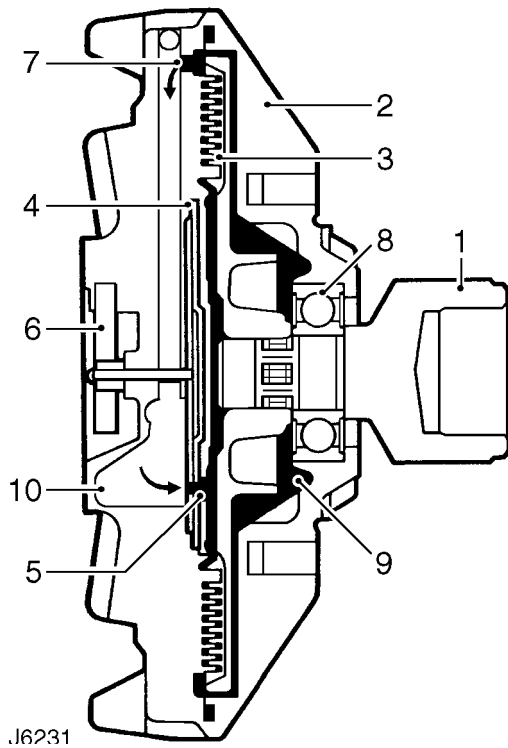

Viscous unit engaged (hot running temperature)

Bi-metal coil (6) expanded, valve (5) open.



ENGINE OVERHEATING

Before conducting any cooling system diagnosis: **See Description and operation, Engine Cooling**

1. Is coolant level correct?
NO - Allow engine to cool, top up level to expansion tank seam.
YES - Continue.
2. Is coolant in radiator frozen?
YES - Slowly thaw and drain system. **See Adjustment, Coolant Requirements**
NO - Continue.
3. Is air flow through radiator restricted or blocked?
YES - Apply air pressure from engine side of radiator to clear obstruction.
NO - Continue.
4. Are there any external leaks, from hoses, coolant pump, engine gaskets or the heater unit?
YES - Investigate and rectify. **See Adjustment, Coolant Requirements**
NO - Continue.
5. Are fan blades fitted correct way round, concave side towards engine?
NO - Rectify.
YES - Continue.

6. Is viscous unit operating correctly? **See Description and operation, Viscous Fan**
NO - Renew. **See Repair, Viscous Coupling**
YES - Carry out a pressure test on radiator cap and system. Check thermostat type, operation and correct fitting **See Repair, Thermostat**

7. Is temperature sender and gauge giving accurate readings?
NO - Substitute parts and compare readings.
YES - Continue.

8. Carry out cylinder pressure test to determine if pressure is leaking into cooling system causing over pressurising and loss of coolant.

If problem is not diagnosed, check the coolant system for engine oil contamination and engine lubrication system for coolant contamination.

If the coolant only, or both systems are contaminated, suspect cylinder head gaskets or radiator.

If only the lubrication system is contaminated with coolant, suspect inlet manifold or front cover gaskets.

ENGINE RUNS COLD

Before conducting any cooling system diagnosis: **See Description and operation, Engine cooling**

1. Check operation of viscous unit. **See Description and operation, Viscous Fan**
Is viscous unit operating correctly?
NO - **See Repair, Viscous coupling**
YES - Continue.
2. Is thermostat correct type and operating? **See Repair, Thermostat**
If problem is not diagnosed: Continue.
3. Are the air conditioning fans operating continuously?
YES - **See Electrical Trouble Shooting Manual.**
NO - Continue.
4. Is temperature sender and gauge giving accurate readings? Substitute parts and compare readings. If problem is not diagnosed repeat tests, starting at 1.



COOLANT REQUIREMENTS

Frost precautions and engine protection.

Cooling system **MUST ALWAYS** be filled and topped-up with solution of water and anti-freeze, winter and summer. **NEVER** use water alone, this may corrode aluminium alloy.



CAUTION: Do not use salt water otherwise corrosion will occur. In certain territories where only available natural water supply has some salt content use only rain or distilled water.

Recommended solutions

Anti-freeze: Universal anti-freeze or permanent type ethylene base, without methanol, containing a suitable inhibitor for aluminium engines and engine parts. **See LUBRICANTS, FLUIDS AND CAPACITIES, Information, Anti-freeze**

Use one part of anti-freeze to one part of water.

Anti-freeze can remain in the cooling system and will provide adequate protection for two years provided that specific gravity of coolant is checked before onset of second winter and topped-up with new anti-freeze as required.

Vehicles leaving factory have cooling system filled with 50% solution of anti-freeze and water. This gives protection against frost down to minus 36°C, minus 33°F. Vehicles so filled are identified by a label affixed to radiator.



NOTE: Should ambient temperatures be below that stated above refer to Anti-Freeze Data in Recommended Lubricants, Fluids and Capacities in Section 09. Instructions in chart must be strictly adhered to before driving vehicle.

After the second winter the system should be drained and thoroughly flushed. Before adding new anti-freeze examine all joints and replace defective hoses to make sure that the system is leakproof.

For protection quantities. **See LUBRICANTS, FLUIDS AND CAPACITIES, Information, anti-freeze**

DRAIN AND REFILL

Service repair no - 26.10.01

Drain



WARNING: Do not remove expansion tank filler cap when engine is hot. The cooling system is pressurised and personal scalding could result. See coolant requirements before refilling system.

1. Remove expansion tank filler cap by slowly turning it anti-clockwise. Pause to allow pressure to escape. Continue turning it in same direction and remove.
2. Remove viscous coupling. **See Repair, viscous coupling**

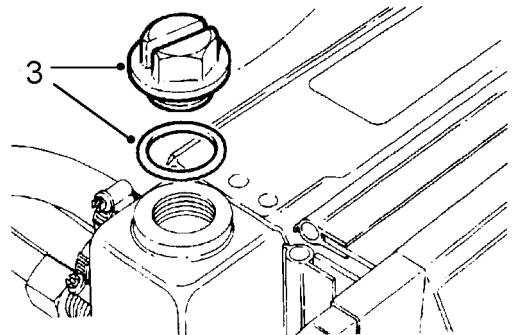

26M0486

3. Remove radiator filler plug and 'O' ring to assist drainage.
4. Position container to collect coolant spillage.

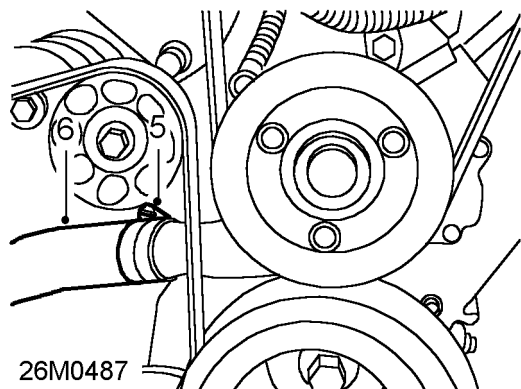

26M0487

5. Loosen clip securing hose to coolant pump.
6. Release hose from coolant pump and allow coolant to drain.



NOTE: It is not possible to drain all coolant retained in heater system.

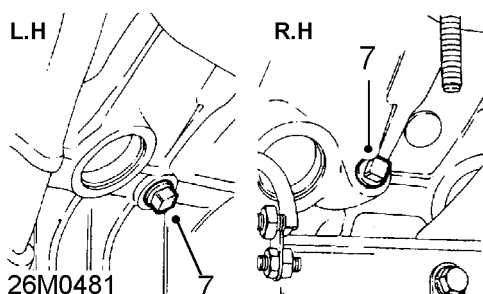

7. Remove engine drain plugs beneath exhaust manifolds and allow coolant to drain from engine.

Refill

1. Fit drain plugs to engine.
2. Connect hose to coolant pump and secure with clip.
3. Fit viscous coupling. **See Repair, viscous coupling**
4. Pour correct solution of water and anti-freeze into expansion tank until radiator is full.
5. Start engine and run until normal operating temperature is reached.
6. Top up coolant level as necessary.
7. Fit new 'O' ring to radiator filler plug.
8. Fit radiator filler plug and tighten to **6 Nm, 4 lbf ft.**
9. Fit expansion tank filler cap.
10. Allow engine to cool and check coolant level.
11. Top-up expansion tank until level reaches seam.
12. Remove container.



EXPANSION TANK

Service repair no - 26.15.01

Remove



WARNING: Do not remove expansion tank filler cap when engine is hot. The cooling system is pressurised and personal scalding could result.

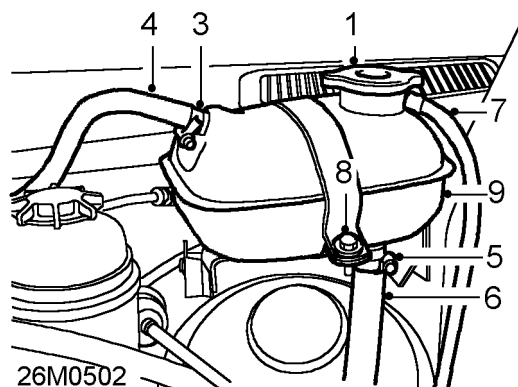

1. Remove expansion tank filler cap by slowly turning it anti-clockwise. Pause to allow pressure to escape then continue to turn in same direction and remove.
2. Position container to collect any coolant spillage.
3. Loosen clip securing radiator hose to expansion tank.
4. Release radiator hose from expansion tank.
5. Loosen clip securing coolant hose to underside of expansion tank.
6. Release coolant hose from expansion tank.
7. Remove overflow pipe from expansion tank.
8. Remove clamping bolt from expansion tank mounting bracket and collect nut and washer.
9. Lift mounting bracket clamp and remove expansion tank.

Refit

10. Fit expansion tank to mounting bracket.
11. Fit and tighten nut and bolt securing expansion tank to mounting bracket.
12. Fit overflow pipe to expansion tank.
13. Connect coolant hose to underside of expansion tank and secure with clip.
14. Connect radiator hose to expansion tank and secure with clip.
15. Remove container.
16. Top-up engine coolant.

VISCOUS COUPLING

Service repair no - 26.25.19

Remove

1. Disconnect battery negative lead.

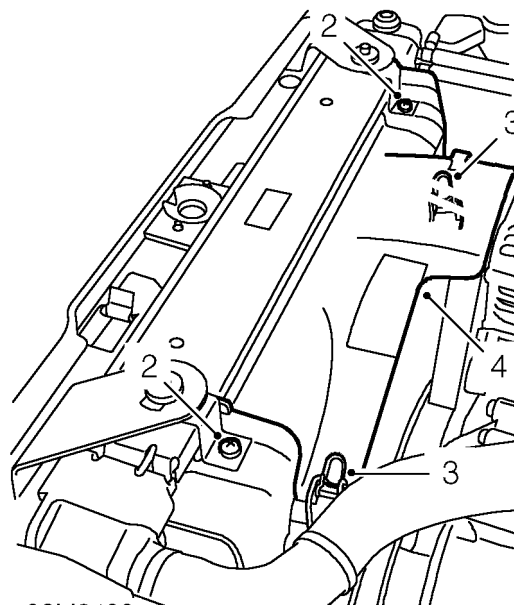

2. Remove 2 screws securing radiator top mountings to fan upper cowl.
3. Release 2 clips securing fan upper cowl to lower cowl.
4. Remove fan upper cowl.

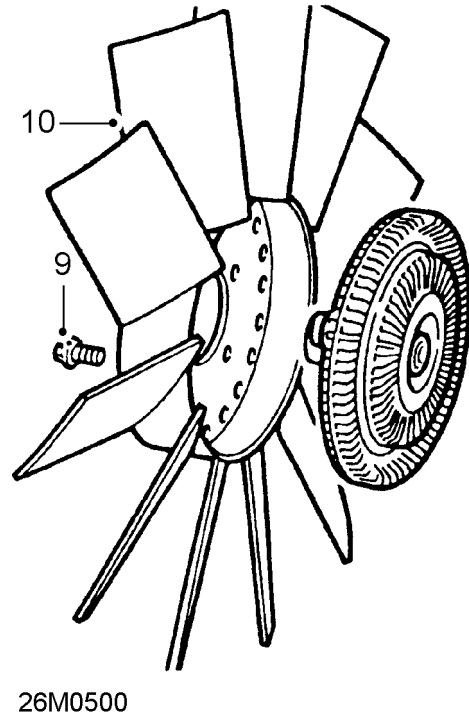
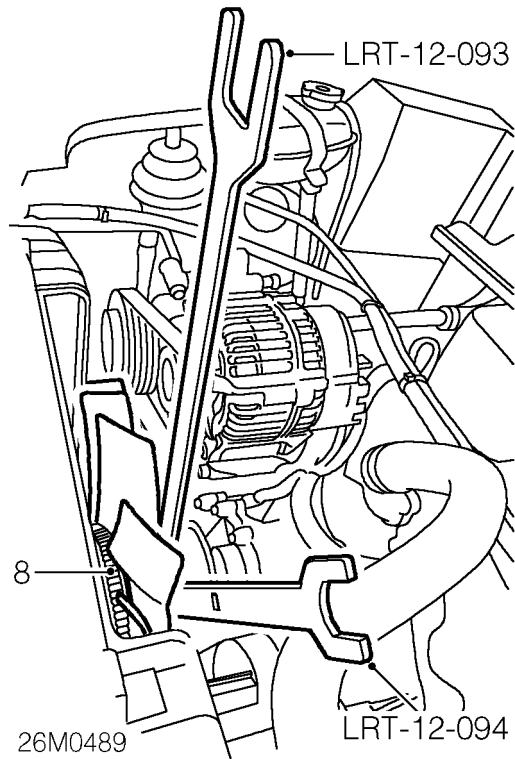

5. Position tool **LRT-12-093** to hold coolant pump pulley.
6. Loosen viscous coupling nut using tool **LRT-12-094**.
7. Remove tool **LRT-12-093**.
8. Remove viscous coupling assembly.

Do not carry out further dismantling if component is removed for access only.

9. Remove 4 Allen screws securing fan blades to coupling.
10. Remove fan blades from coupling.

Refit

11. Clean mating faces of fan blades and coupling.
12. Fit fan blades to coupling and secure with Allen screws.
13. Position coupling assembly and start tightening nut.
14. Position tool **LRT-12-093** to hold pulley.
15. Tighten viscous coupling assembly nut using tool **LRT-12-094**.
16. Remove tools.
17. Fit fan upper cowl and secure with clips.
18. Align fan cowl fixings to upper mounting brackets and secure with screws.
19. Reconnect battery negative lead.



RADIATOR

Service repair no - 26.40.01

Remove

1. Disconnect battery negative lead.
2. Drain cooling system. **See Adjustment, drain and refill**

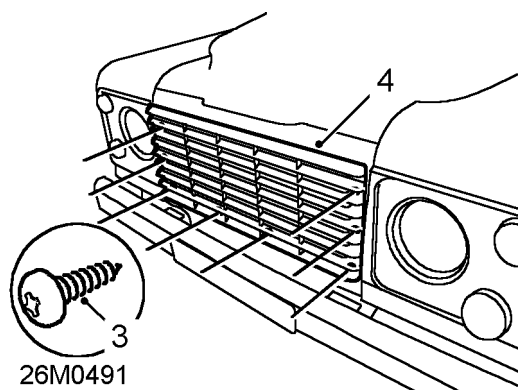

3. Remove 8 screws securing front grille to body.
4. Remove front grille.

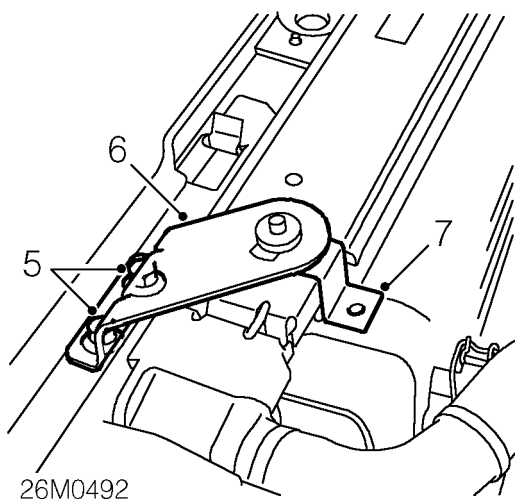

5. Remove 4 bolts securing radiator top mountings to bonnet locking panel and collect nuts.
6. Remove radiator top mountings.
7. Remove fan cowl upper mounting brackets.

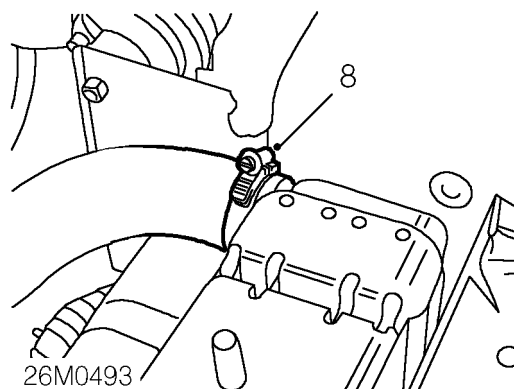

8. Loosen clip and disconnect top hose from radiator.

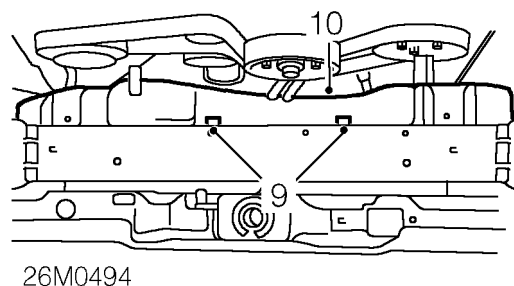

9. Remove 2 clips securing fan cowl to radiator.

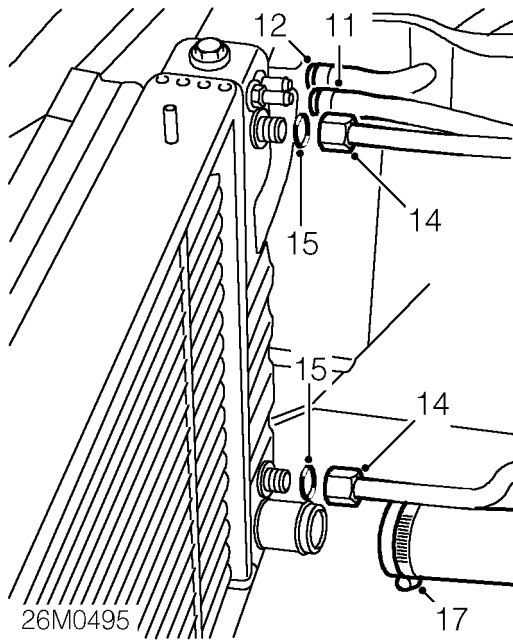

10. Remove fan cowl.
11. Loosen clip and disconnect throttle body to radiator hose.
12. Loosen clip and disconnect expansion tank to radiator hose.
13. Position container beneath engine oil cooler pipe unions.
14. Loosen engine cooler pipes and disconnect from radiator.
15. Remove and discard 'O' rings from oil cooler pipes.
16. Plug oil cooler pipe connections.
17. Loosen clip and disconnect bottom hose from radiator.
18. Release radiator from lower mounting rubbers and remove radiator.

Refit

19. Fit radiator and secure to lower mounting rubbers.



NOTE: Ensure condenser lower mounting brackets are located to radiator lower mounting brackets.

20. Connect bottom hose to radiator and secure with clip.
21. Remove plugs from engine oil cooler pipe connections.
22. Clean oil cooler pipe connections.
23. Lubricate NEW 'O' rings with clean engine oil and fit to pipes.
24. Connect oil cooler pipes to radiator and tighten unions to **30 Nm, 22 lbf ft.**
25. Remove container.
26. Connect expansion tank hose to radiator and tighten clip.
27. Connect throttle body hose to radiator and tighten clip.
28. Fit fan cowl to radiator.
29. Fit fan cowl lower retaining clips.
30. Connect top hose to radiator and tighten clip.
31. Fit fan upper cowl and secure with clips.
32. Fit fan cowl upper mounting brackets.
33. Fit radiator top mountings and secure with screws and bolts.
34. Fit front grille and secure with screws.
35. Refill cooling system. **See Adjustment, drain and refill**
36. Reconnect battery negative lead.



THERMOSTAT

Service repair no - 26.45.01

Remove

1. Disconnect battery negative lead.
2. Drain cooling system. **See Adjustment, drain and refill**

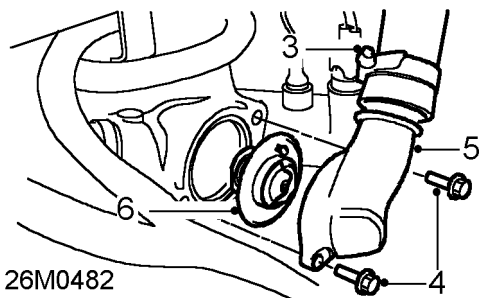

26M0482

3. Loosen clip and disconnect radiator top hose from coolant outlet elbow.
4. Remove 2 bolts securing coolant outlet elbow to engine.
5. Remove coolant outlet elbow and collect gasket.
6. Remove thermostat.

Refit

7. Fit thermostat ensuring jiggle pin/vent hole is uppermost.
8. Fit coolant outlet elbow with new gasket.
9. Fit and tighten bolts securing coolant outlet elbow to **28 Nm, 21 lbf ft.**
10. Connect radiator top hose to coolant outlet elbow tighten clip.
11. Refill cooling system. **See Adjustment, drain and refill**
12. Reconnect battery negative lead.

COOLANT PUMP

Service repair no - 26.50.01

Remove

1. Drain cooling system. **See Adjustment, drain and refill**
2. Loosen coolant pump pulley bolts.

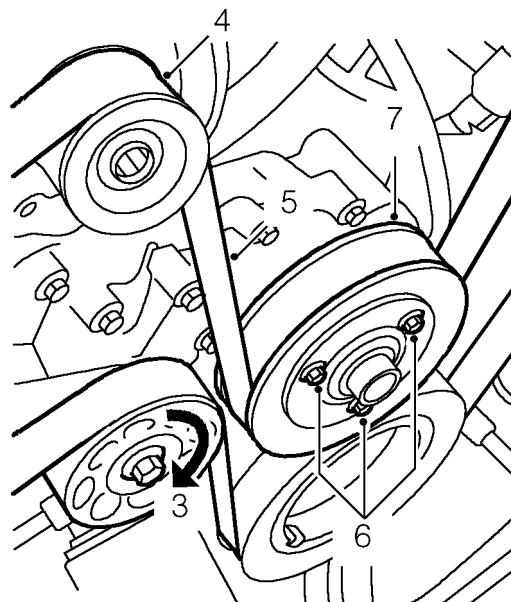

26M0483

3. Release auxillary drive belt tension by turning tensioner clockwise.
4. With tension released, remove belt from alternator pulley.
5. Remove drive belt.



NOTE: If belt is to be refitted, mark direction of rotation.

6. Remove bolts securing coolant pump pulley.
7. Remove coolant pump pulley.

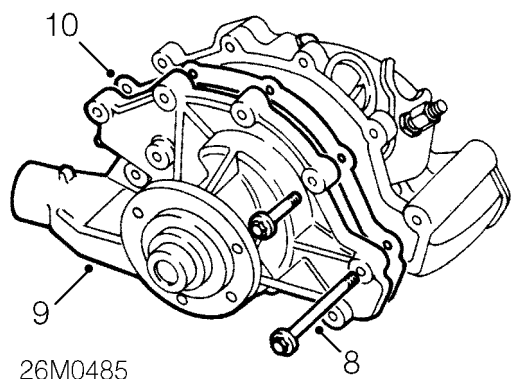

8. Noting their fitted positions, remove 9 bolts securing coolant pump.
9. Remove coolant pump.
10. Remove gasket.

Refit

11. Clean coolant pump and timing cover mating faces.
12. Lightly grease NEW gasket and position to timing cover.
13. Clean threads of all long bolts and coat with Loctite 572 thread sealant.
14. Position coolant pump, fit bolts and tighten to **28 Nm, 21 lbf ft.**
15. Fit coolant pump pulley, fit bolts but do not tighten.
16. Clean auxillary drive belt pulley grooves and inspect for damage.
17. Fit belt to pulleys.
18. Turn drive belt tensioner clockwise and engage belt on alternator pulley.
19. Release drive belt tensioner.
20. Tighten coolant pump pulley bolts.
21. Refill cooling system. **See Adjustment, drain and refill**



TORQUE VALUES

	Nm	lbf ft
Oil cooler pipes	30	22
Radiator filler plug (plastic)	6	4.5



CATALYTIC CONVERTERS - V8i

Description

Catalytic converters which form part of the engine emission control system, are designed to 'clean' the exhaust gases, by chemically converting pollutant elements in the exhaust to gases less harmful to the environment.

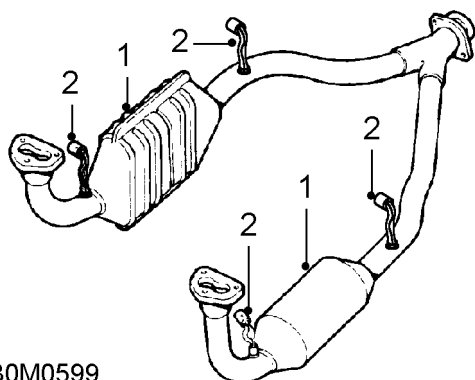

30M0599

1. Catalysts
2. Oxygen sensors

The front section of the exhaust system from each cylinder bank contain the ceramic elements of the catalytic converters. The oxygen sensors, which transmit information to the fuel ECM for control of the mixture, are located in the exhaust down pipes.

The Hydrocarbons (HC), Nitrogen oxides (NO_x) and Carbon monoxide (CO) emitted by the engine react with the catalytic element and exhaust temperature to convert the toxic gas, into Nitrogen (N_2), Carbon dioxide (CO_2) and water vapour (H_2O).

The sophisticated closed loop control system ensures that mixture is always kept at the optimum level for peak catalyst efficiency. Also, the advanced On Board Diagnostics ensure that any faults likely to cause damage to the catalyst are indicated to the driver.

However, should the engine be supplied with a rich mixture causing high CO in the exhaust gas, the ceramic element will become coated and the useful life of the catalyst reduced. If the mixture is too weak, excess oxygen in the exhaust gas will cause the catalysts to burn out. Similarly, should a cylinder misfire occur, the unburnt fuel and unburnt oxygen can cause a catalyst burn out.



CAUTION: The catalyst matrices are fragile ceramic 'honeycombs' which can become damaged if roughly treated. Do not use a hammer or mallet when working on the exhaust system.



INTERMEDIATE PIPE

Service repair no - 30.10.11

Remove

1. Raise vehicle on ramp [hoist].

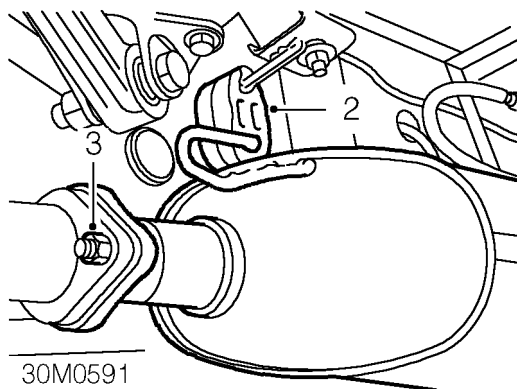

2. Release intermediate pipe from mounting rubber.
3. Remove 2 nuts securing intermediate pipe to tail pipe.

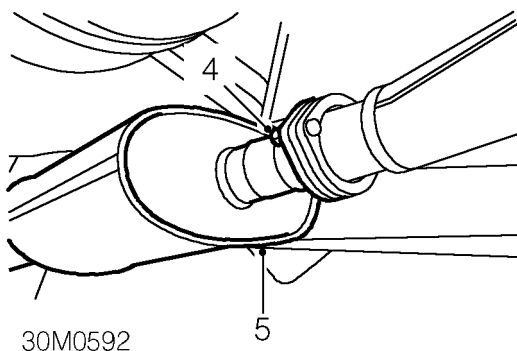

4. Remove 2 nuts securing intermediate pipe to front pipe.
5. Release intermediate pipe from front and tail pipes and remove.

Refit

6. Fit intermediate pipe to front and tail pipes.
7. Secure intermediate pipe to mounting rubber.
8. Fit and tighten nuts securing intermediate pipe to front pipe, **30 Nm, 22 lbf ft.**
9. Fit and tighten nuts securing intermediate pipe to tail pipe, **30 Nm, 22 lbf ft.**
10. Lower vehicle.

TAIL PIPE

Service repair no - 30.10.22

Remove

1. Raise vehicle on a ramp [hoist].

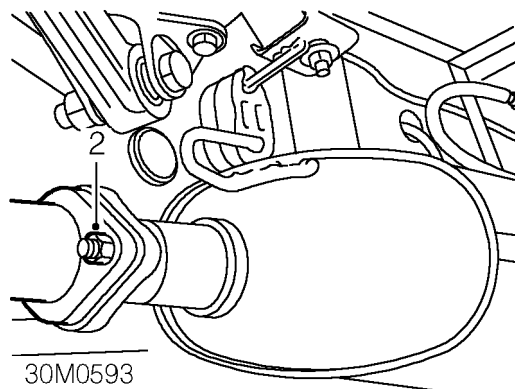

2. Remove 2 nuts securing tail pipe to intermediate pipe.

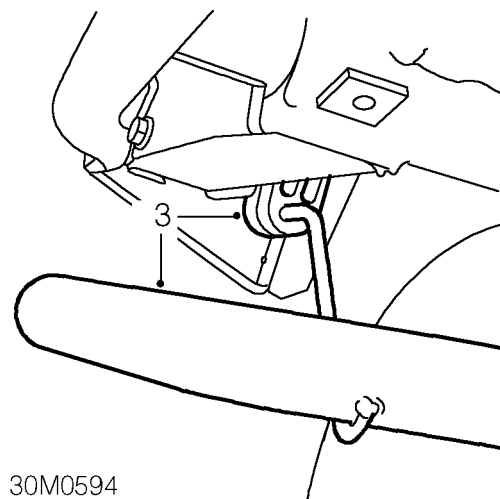

3. Release tail pipe from mounting rubber.
4. Release tail pipe from intermediate pipe and feed over rear axle.
5. Remove tail pipe.

Refit

6. Feed tail pipe over rear axle and connect to intermediate pipe.
7. Secure tail pipe to mounting rubber.
8. Fit nuts and tighten tail pipe to intermediate pipe. **30 Nm, 22 lbf ft.**
9. Lower vehicle.



TORQUE VALUES

MANIFOLDS AND EXHAUSTS - V8i

	Nm	lbf ft
Inlet manifold to cylinder head	38	28
Exhaust manifold to cylinder head	20	15
Exhaust front pipe to manifold	45	33
Exhaust front pipe to intermediate pipe	30	22
Exhaust intermediate pipe to rear pipe	30	22



LT230Q TRANSFER GEARBOX

Description

The LT230Q transfer gearbox is a permanent 4 wheel drive, two speed ratio reducing gearbox, incorporating high and low range outputs with mechanically lockable centre differential (diff-lock). High/low range and diff-lock selection are made via a single lever located forward of the main gear lever.

The transfer gearbox is mounted at the rear of the main gearbox, the mainshaft of which extends into the transfer casing. A transfer gear, supported on taper roller bearings and splined to the gearbox mainshaft, passes the drive to an intermediate gear cluster supported on a single shaft and rotating on taper roller bearings.

The intermediate gears pass the drive to high and low speed gears on the rear output shaft. The rear output shaft passes through the speed transducer drive housing, which also forms the mounting for the park brake. A worm gear fitted to the rear output shaft drives a pinion fitted in the speed transducer housing.

Integral with the output shafts is a differential assembly which compensates for speed differences between the front and rear prop shafts. To prevent all the power being transmitted to the axle offering the least resistance, a diff-lock is provided. Selection of differential lock engages, through mechanical linkage, a dog clutch with the front output shaft, this action locks the centre differential and provides a fixed drive, giving equal power to the front and rear output shafts.

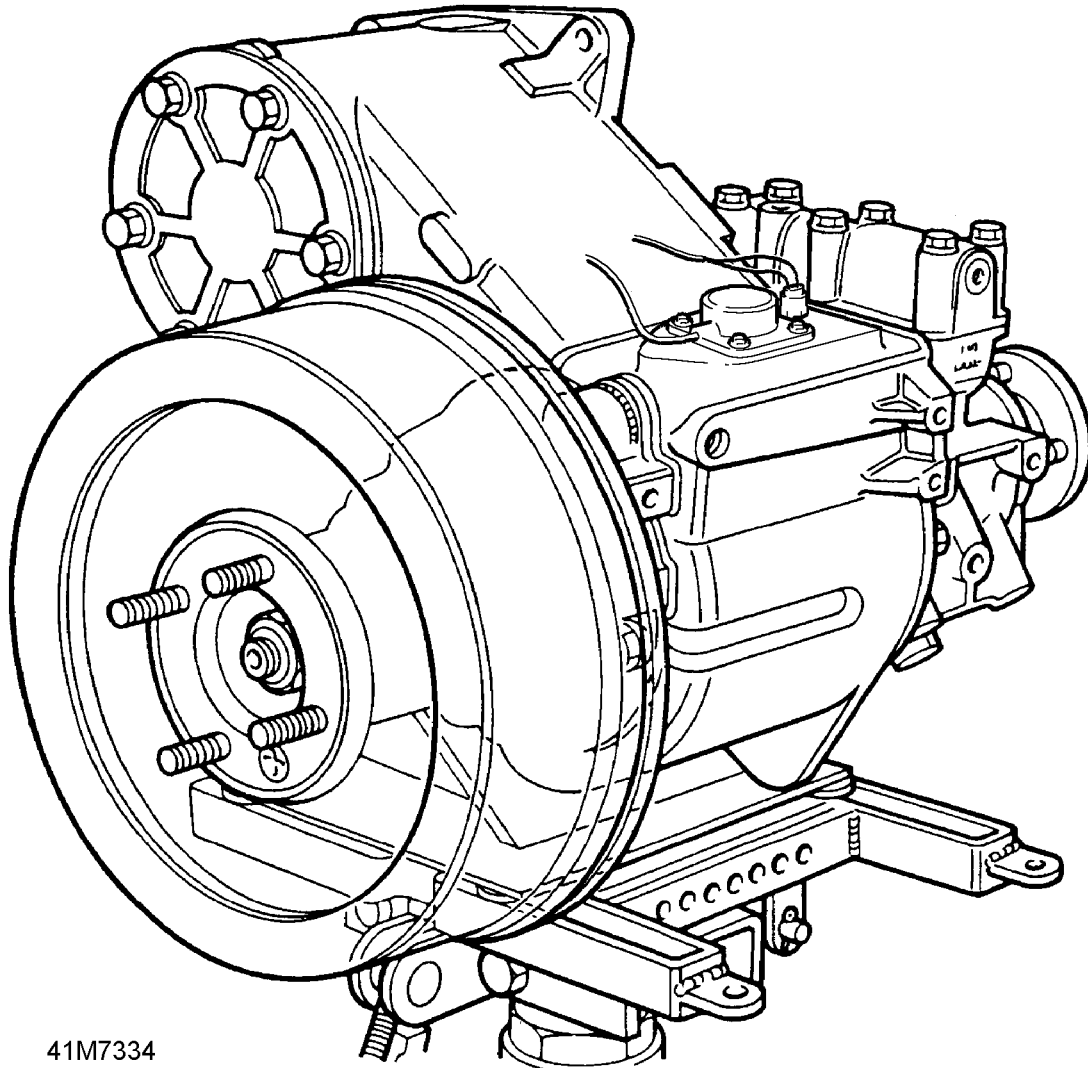

41M7334

The diff-lock should only be engaged during severe off-road conditions and should be disengaged as soon as conditions permit.

A shiftlock device, used as a park facility, is fitted and prevents accidental gear disengagement when the ignition is switched off. An audible neutral alarm is also fitted to alert the driver, when parking, to move the gear lever to the high or low position.



**LT230Q TRANSFER GEARBOX - OIL SEAL
LOCATIONS**

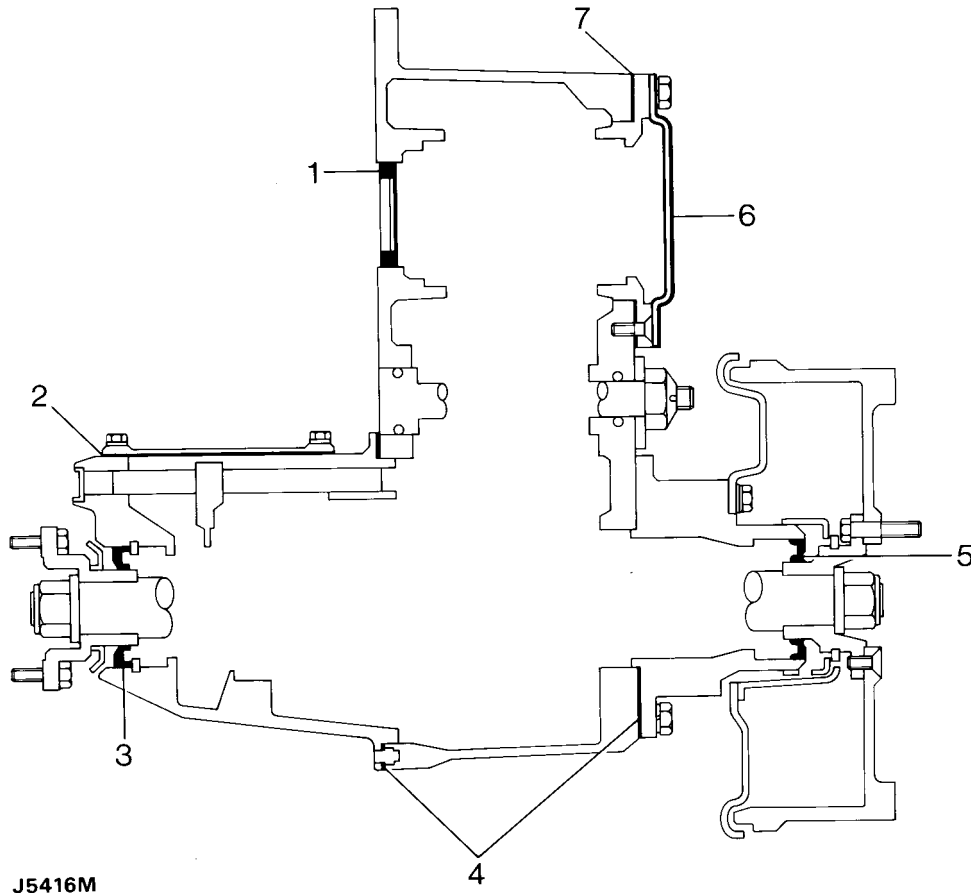

J5416M

- | | |
|--|--------------------------------------|
| 1. Input seal. | 5. Rear output seal. |
| 2. Cover plate joints. | 6. Power take off cover plate joint. |
| 3. Front output seal. | 7. Bearing plate joint. |
| 4. Front and rear housing joint faces. | |

OIL LEAKS

Verify that oil leak is from transfer box and not main gearbox before proceeding with checks.

Prior to road test

1. Check oil level in transfer box is correct.
2. Check tightness of level and drain plugs.
3. Check breather system for blockage. To validate system pipe must be removed, inspected, rectified as necessary and refitted.
4. Remove all traces of oil from exterior of transfer box.

Take vehicle for short road test.

1. Identify source of leaks and rectify as follows.

Front or rear output seal leaking:-

1. Drain oil and remove leaking output flange.
2. Inspect seal track on flange for surface damage. If damaged renew component.
3. Remove and discard oil seal.
4. Inspect seal locating bore and remove any sharp edges which may damage new oil seal.
5. Fit new seal.
6. Fit output flange and all other parts.
7. Add oil to correct level into gearbox. **See LUBRICANTS, FLUIDS AND CAPACITIES, Information, Recommended Lubricants and Fluids**

Cover plate sealant leaking.

1. Drain oil and remove leaking cover plate.
2. Remove all traces of joint sealant from both joint faces.
3. Degrease all components and apply a thin film of Hylomar sealant, to both joint faces.
4. Apply thread sealant to bolts which come into contact with gearbox oil.
5. Refit cover plate.



CAUTION: Care must be taken not to overtighten fixings.

Leak between main and transfer gearboxes.

1. Site vehicle onto a ramp [hoist].
2. Select neutral in transfer box and select 4th gear in main gearbox.
3. Run engine at 2000 rpm with clutch/drive engaged.
4. Observe joint between main and transfer boxes.
5. If oil leak is found establish if it is gear oil.
6. If so, leak is originating from transfer box.
7. Check two inner (main/transfer) bolts are oil tight, as these holes are tapped into the main transfer case.
8. Remove transfer box to inspect mainshaft collar seal track condition, and front face of transfer case for porosity. **See Repair, LT230Q Transfer Gearbox**
9. If these areas require servicing, transfer gearbox input seal must also be renewed.



CAUTION: Avoid damaging new seal lip and ensure seal is fitted flush with machined face. Also ensure new seal is not damaged when refitting transfer gearbox.

10. If red A.T.F type oil is seen leaking during workshop test, investigate main gearbox for cause of leak.

Detent plug or electrical switch leaks.

1. Detent plugs and electrical switches do not usually leak. It must be noted that they fit into open tapped holes in transfer case and therefore should be considered when looking for source of leak.



LT230Q TRANSFER GEARBOX

Service repair no - 41.20.25/99

Remove

The transfer gearbox should be removed from underneath the vehicle, using a hydraulic hoist and adaptor plate **LRT-99-010**.

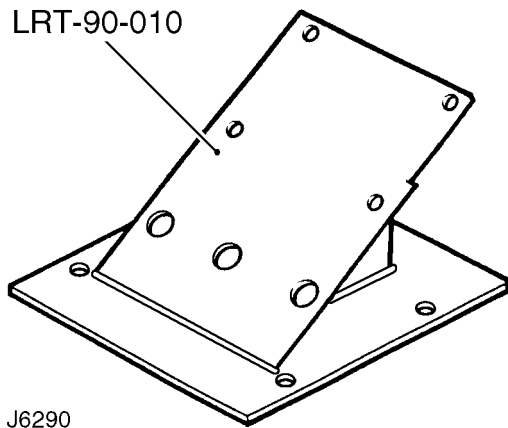

J6290

⚠ WARNING: Where use of a transmission hoist is necessary, it is absolutely essential to follow the manufacturers' instructions to ensure safe and effective use of the equipment.

1. Position vehicle on a ramp [hoist].
2. Select LOW range gear and leave vehicle in neutral.
3. Disconnect battery negative lead.
4. Remove centre console. **See CHASSIS AND BODY, Repair, centre console**

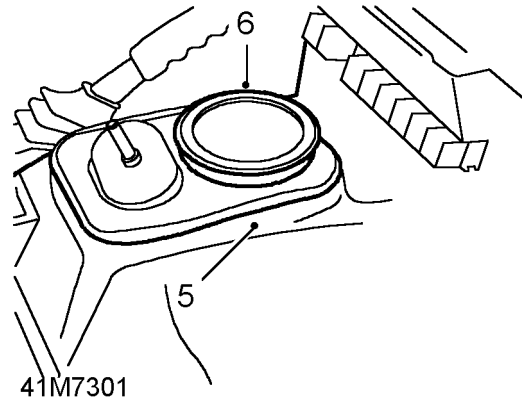

5. Remove carpet from transmission tunnel.
6. Remove high-low selector housing cover from transmission tunnel.

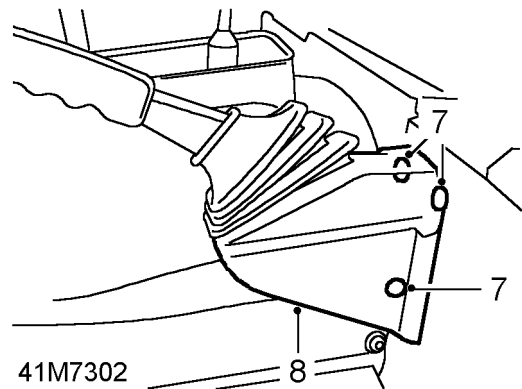

7. Remove 3 trim studs securing handbrake lever gaiter.
8. Release handbrake lever gaiter for access to handbrake cable linkage.

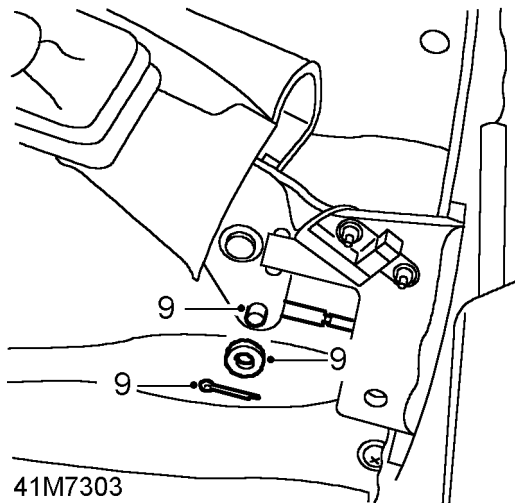

41M7303

9. Remove split [cotter] pin and clevis pin securing handbrake cable to lever.

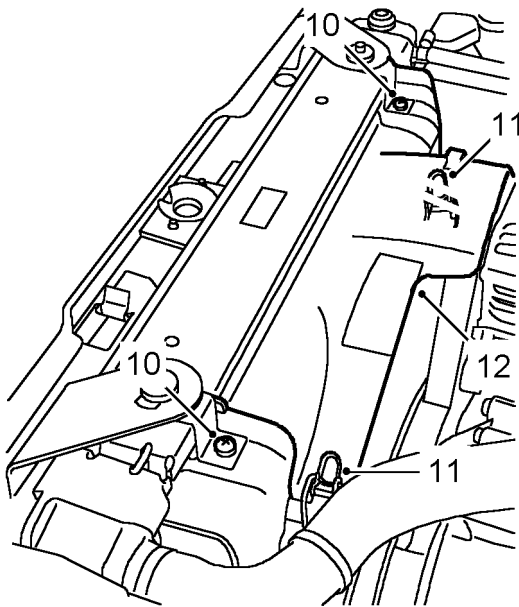

41M7304

10. Remove 2 screws securing fan cowl to upper retaining brackets.
 11. Release 2 clips securing upper fan cowl.
 12. Remove upper fan cowl.
 13. Raise ramp [hoist].
 14. Drain transfer gearbox oil. **See SECTION 10, Maintenance, under vehicle maintenance**
 15. Remove exhaust front pipe. **See EMISSION CONTROL, Repair, front pipe/catalytic converter**

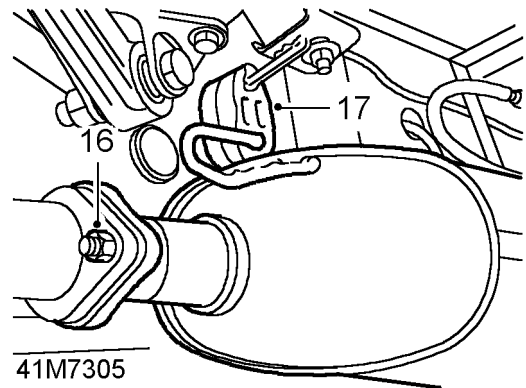

41M7305

16. Remove 2 nuts securing intermediate pipe to tail pipe.
 17. Release intermediate pipe from tail pipe and remove from mounting.

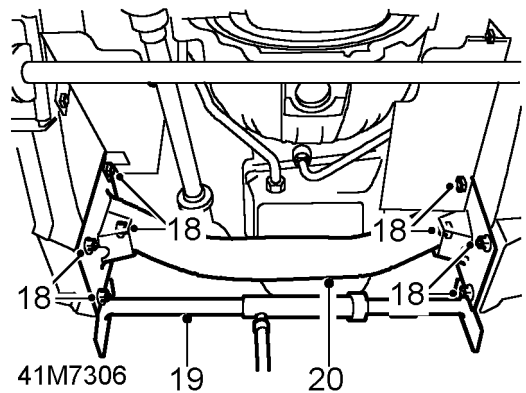

41M7306

18. Remove 8 bolts securing chassis crossmember.
 19. With assistance and using a body jack between chassis longitudinals, jack chassis sufficiently to enable removal of crossmember.
 20. Remove crossmember.
 21. Remove body jack.

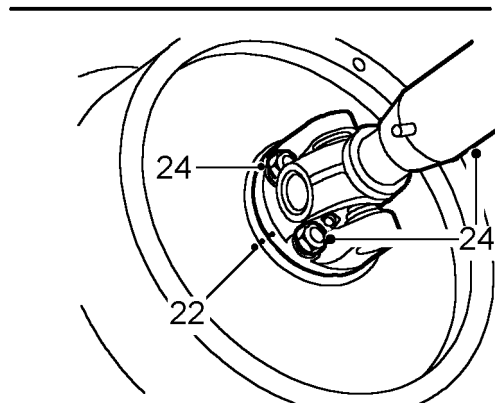
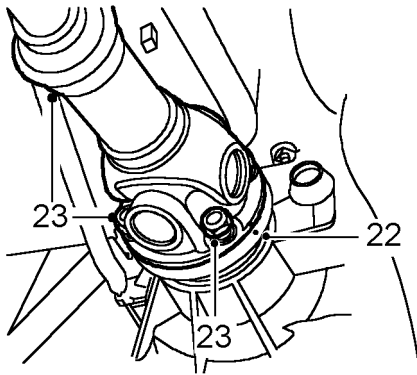

41M7307

- 22. Using a centre punch, mark relationship between front propeller shaft and transfer box drive flanges and rear propeller shaft and brake drum drive flanges.
- 23. Remove 4 nuts securing front propeller shaft to transfer box flange. Release propeller shaft from flange and tie aside.
- 24. Remove 4 nuts securing rear propeller shaft to brake drum flange. Release propeller shaft from flange and tie aside.

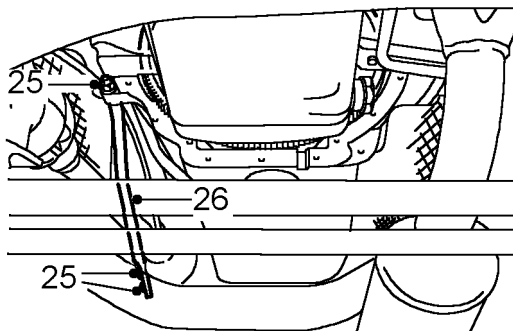

41M7308

- 25. Remove nut securing tie bar to gear box and 2 bolts securing tie bar to transfer box.
- 26. Remove tie bar.

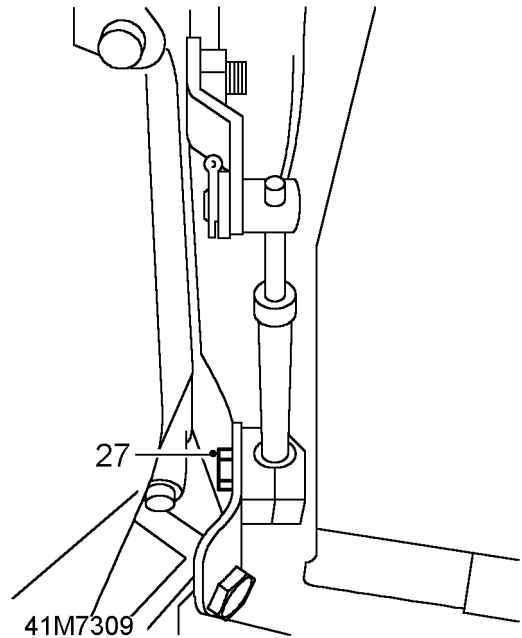

41M7309

- 27. Remove bolt securing selector outer cable clamp to transfer gearbox LH mounting.

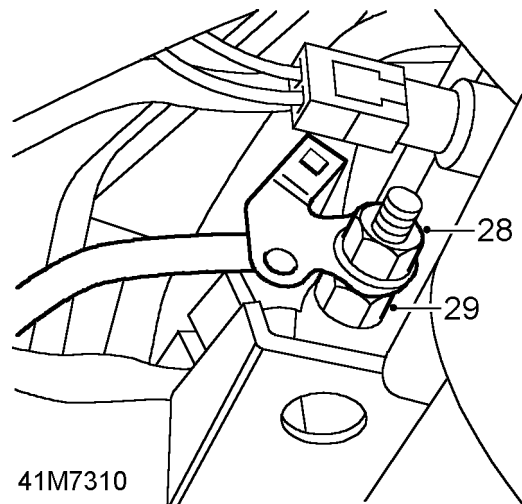

41M7310

- 28. Remove nut securing oxygen sensor multiplug bracket to transfer gearbox earth bolt and collect bracket.
- 29. Remove nut securing earth strap to transfer gearbox and release strap.

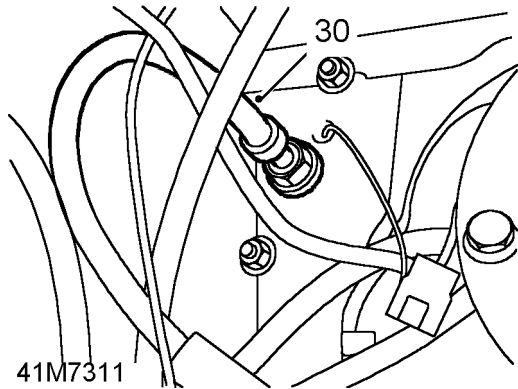

41M7311

30. Release handbrake outer cable from body.

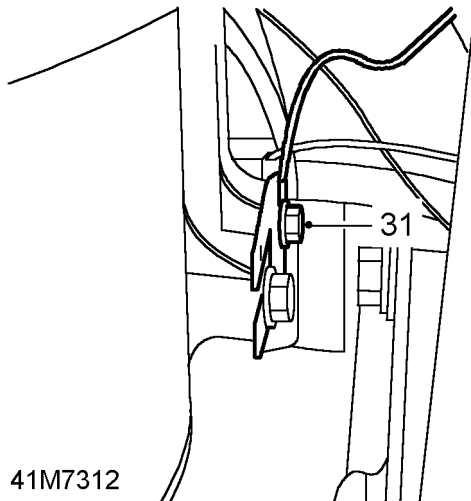

41M7312

31. Remove bolt securing ground lead to RH side of transfer gearbox.
 32. Remove bolt securing handbrake cable heat shield. Remove heat shield.
 33. Position adaptor plate, **LRT-99-010**, and secure to transmission hoist with 4 bolts.

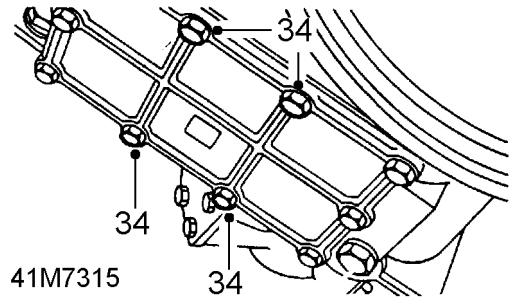

41M7315

34. Remove 4 central bolts from transfer gearbox bottom cover, move hoist into position and secure adaptor plate to transfer box.
 35. Adjust hoist to take weight of transfer gearbox.

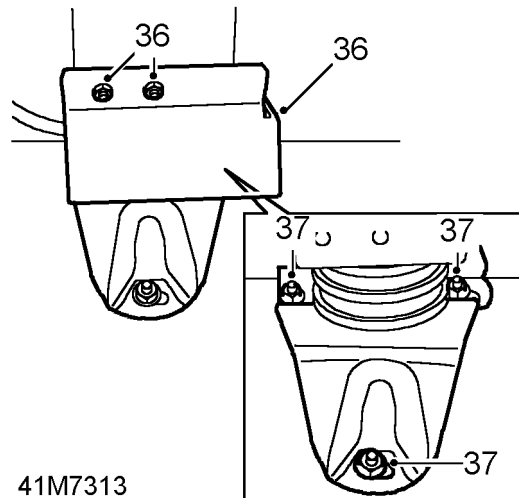

41M7313

36. Remove 2 nuts and bolts securing heat shield to transfer gearbox LH mounting bracket. Remove heat shield.
 37. Remove 3 nuts and bolts securing LH gearbox mounting bracket to chassis.

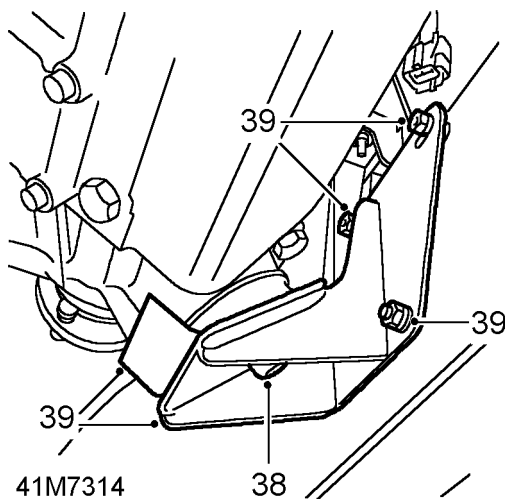

38. Remove nut securing transfer gearbox RH mounting to mounting rubber.
39. Remove 3 nuts and bolts securing transfer gearbox mounting bracket to chassis. Remove transfer box RH mounting bracket and collect rubber mounting heat shield.
40. Lower transmission sufficiently to gain access to harness connectors and transfer box breather pipe connection.

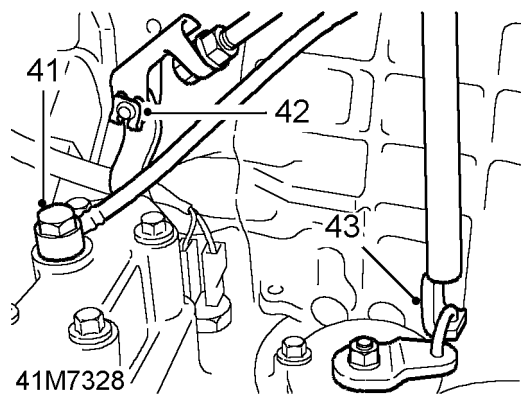

41. Remove banjo bolt from transfer box breather pipe and collect 2 sealing washers. Discard sealing washers.
42. Remove retaining clip and disconnect high/low lever from operating rod.
43. Remove 2 clips at lower end of pivot arm and disconnect differential lock lever link.
44. Disconnect the following multiplugs/connectors from transfer box:
 - Speed transducer
 - Parking solenoid
 - Neutral detection switch
 - Differential lock
 - Temperature sensor switch

45. Remove 2 clips securing harness to transfer box.
46. Position a jack to support main gearbox.



CAUTION: Use a block of wood or hard rubber pad to protect gearbox.

47. Remove nut and 4 bolts securing transfer box to main gearbox extension case.
48. Fit 3 guide studs, LRT-41-009, through transfer box bolt holes to support it during removal.
49. Lower hoist and withdraw transfer box from main gearbox.
50. Remove transfer box.

Refit

51. Ensure joint faces of transfer box and main gearbox are clean and guide studs, LRT-41-009, are fitted to extension case.
52. Lubricate oil seal in joint face of transfer box.
53. Secure transfer box to adaptor plate on lifting hoist and raise hoist until transfer box can be located over guide studs.
54. Remove guide studs, and secure transfer box to main gearbox extension case. Tighten fixings to **45 Nm, 33 lbf/ft.**
55. Connect multiplugs/connectors to transfer box.
56. Position breather pipe to transfer box, fit new sealing washers and tighten banjo bolt to **15 Nm, 11 lbf ft.**
57. Fit link to differential lock lever and pivot arm and secure with retaining clips.
58. Connect high/low lever to operating rod and secure with retaining clip.
59. Raise hoist and remove jack supporting main gearbox.
60. Position RH mounting rubber heat shield and mounting bracket and secure loosely with retaining nut.
61. Align RH mounting bracket to chassis and secure with nuts and bolts.
62. Tighten nut securing RH mounting.
63. Align LH mounting bracket to chassis and secure with nuts and bolts.



NOTE: Position ground lead to mounting bolt.

64. Remove 4 bolts securing hoist adaptor plate to transfer box bottom cover.
65. Lower hoist and move aside.
66. Clean threads of the 4 bolts, coat with Loctite 290, and fit to transfer box bottom cover. Tighten to **25 Nm, 18 lbf/ft.**
67. Position handbrake cable heat shield and tighten bolt.
68. Position ground lead to RH side of transfer box and tighten bolt.
69. Feed handbrake cable through body.
90. Position handbrake lever cover and secure with trim studs.
91. Fit high-low selector housing cover to transmission tunnel.
92. Fit carpet to transmission tunnel.
93. Fit centre console. **See CHASSIS AND BODY, Repair, centre console**
94. Reconnect battery negative lead.
95. Check park brake operation and adjust if necessary. **See SECTION 10, Maintenance, vehicle interior**



NOTE: Apply a soap solution to aid fitment of cable.

70. Position ground strap to transfer box stud and tighten nut.
71. Fit heated oxygen sensor multiplug bracket to stud and tighten nut.
72. Position selector outer cable clamp to transfer box LH mounting and tighten bolt.
73. Fit tie bar and tighten bolts and nut.
74. Clean rear propeller shaft and brake drum flange mating faces.
75. Release propeller shaft, align flange markings and connect to studs.
76. Fit nuts securing propeller shaft and tighten to **47 Nm, 33 lbf ft.**
77. Clean front propeller shaft and transfer box flange mating faces.
78. Release propeller shaft, align flange markings and connect to studs.
79. Fit nuts securing propeller shaft and tighten to **47 Nm, 33 lbf ft.**
80. With assistance and using a body jack between chassis longitudinals, jack chassis sufficiently to enable fitment of crossmember.
81. Fit crossmember and tighten bolts.
82. Clean intermediate and tail pipe flanges.
83. Fit intermediate pipe to mounting rubber, connect to tail pipe and tighten nuts.
84. Fit exhaust front pipe. **See EMISSION CONTROL, Repair, front pipe/catalytic converter**
85. Refill transfer box with recommended oil. **See SECTION 10, Maintenance, under vehicle maintenance .**
86. Lower vehicle ramp.
87. Fit upper fan cowl and secure clips.
88. Align fan cowl to upper retaining brackets and tighten screws.
89. Align handbrake cable to lever, fit clevis pin and secure with new split [cotter] pin.



SHIFTLOCK SOLENOID

Service repair no - 41.20.63

Remove

1. Remove centre console. *See CHASSIS AND BODY, Repair, Centre console*
2. Remove carpet from transmission tunnel.

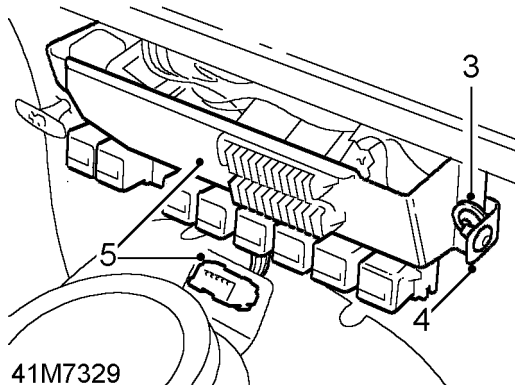

41M7329

3. Remove 2 screws securing relay panel.
4. Retain 2 centre console screw brackets and spacers.
5. Release connector J1962 from bracket on tunnel cover and move relay panel aside to gain access to tunnel cover top fixings.

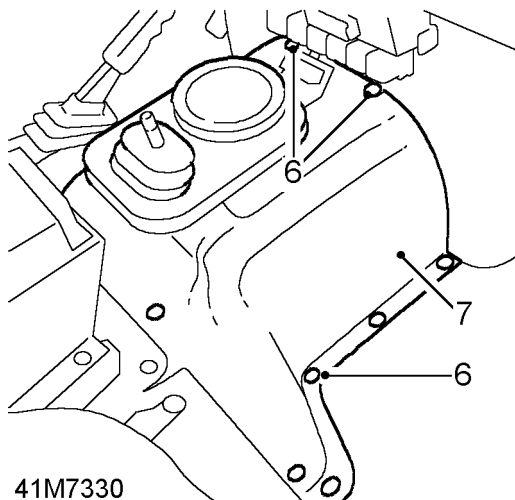

41M7330

6. Remove 15 screws securing tunnel cover.
7. Release and remove tunnel cover.

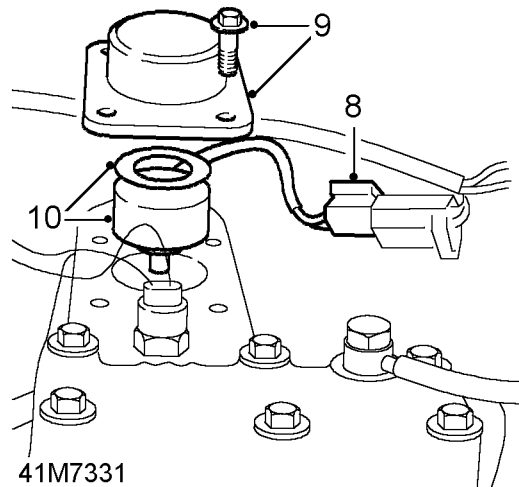

41M7331

8. Disconnect shiftlock solenoid multiplug.
9. Remove 4 bolts and release solenoid cover from transfer box.
10. Remove solenoid and washer.
11. Clean joint sealant from mating faces.

Refit

12. Apply Hylosil or equivalent sealant to mating faces.
13. Fit solenoid. Ensure solenoid multiplug lead is located in cover recess.
14. Secure solenoid cover to transfer box. Tighten bolts to **9 Nm (7 lbf/ft)**.
15. Connect solenoid multiplug.
16. Fit tunnel cover.
17. Secure connector J1962 to bracket on tunnel cover.
18. Position centre console screw bracket and spacers and fit relay panel.
19. Fit tunnel carpet.
20. Fit centre console. *See CHASSIS AND BODY, Repair, Centre console*

NEUTRAL SWITCH

Service repair no - 41.20.64

Remove

1. Remove centre console. *See CHASSIS AND BODY, Repair, Centre console*
2. Remove carpet from transmission tunnel.

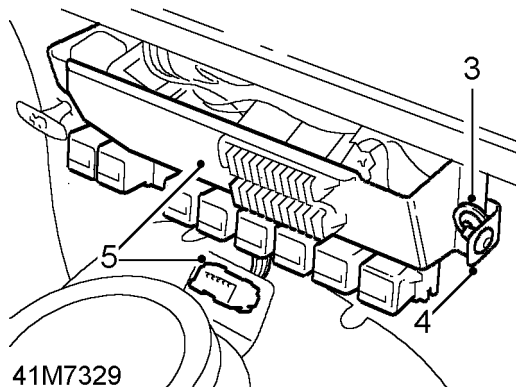

41M7329

3. Remove 2 screws securing relay panel.
4. Retain 2 centre console screw brackets and spacers.
5. Release connector (J1962) from bracket on tunnel cover and move relay panel aside to gain access to tunnel cover top fixings.

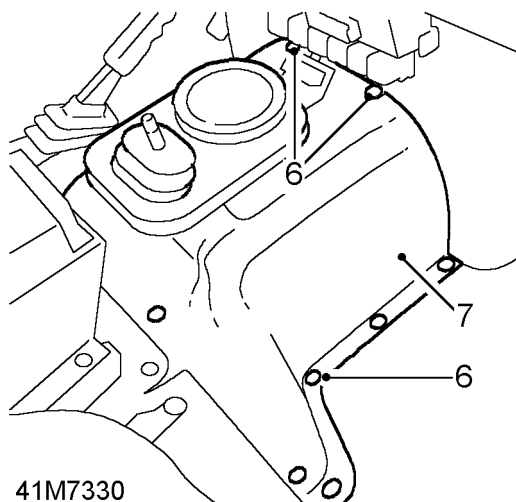

41M7330

6. Remove 15 screws securing tunnel cover.
7. Release and remove tunnel cover.

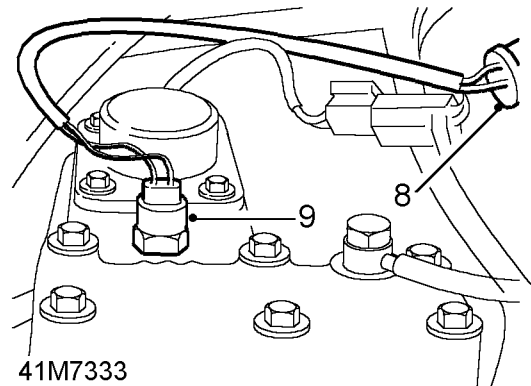

41M7333

8. Disconnect neutral switch multiplug.
9. Remove neutral switch from transfer box.
10. Clean sealant from switch.

Refit

11. Apply Hylomar PL32/L20 or equivalent sealant to neutral switch.
12. Fit switch to transfer box and tighten to **25 Nm (18 lbf/ft)**.
13. Connect switch multiplug.
14. Fit tunnel cover.
15. Secure connector (J1962) to bracket on tunnel cover.
16. Position centre console screw bracket and spacers and fit relay panel.
17. Fit tunnel carpet.
18. Fit centre console. *See CHASSIS AND BODY, Repair, Centre console*



TORQUE VALUES

LT230Q Transfer gearbox

	Nm	lbf ft
Bottom cover to transfer case	25	18
Transfer breather	15	11
Transfer box front drive flange to drive shaft	45	33
Transfer box rear drive flange to drive shaft	45	33
Transfer box to gearbox extension case	45	33



NOTE: The following torque values are for screws and bolts not specified in the previous table.

METRIC	Nm	lbf ft
M5	6	5
M6	9	7
M8	25	18
M10	45	33
M12	90	65
M14	105	75
M16	180	130

UNC / UNF

1/4	9	7
5/16	25	18
3/8	40	30
7/16	80	60
1/2	90	65
5/8	135	100



DESCRIPTION

The automatic transmission is specially tailored version of the ZF 4HP22, used by many manufacturer's of high performance vehicles.

A three element torque converter delivers the power to a four speed epicyclic transmission. First, second and third gears are reduction ratios but fourth is an overdrive gear for high speed cruising. A direct drive clutch, integral with the torque converter operates to engage fourth gear.

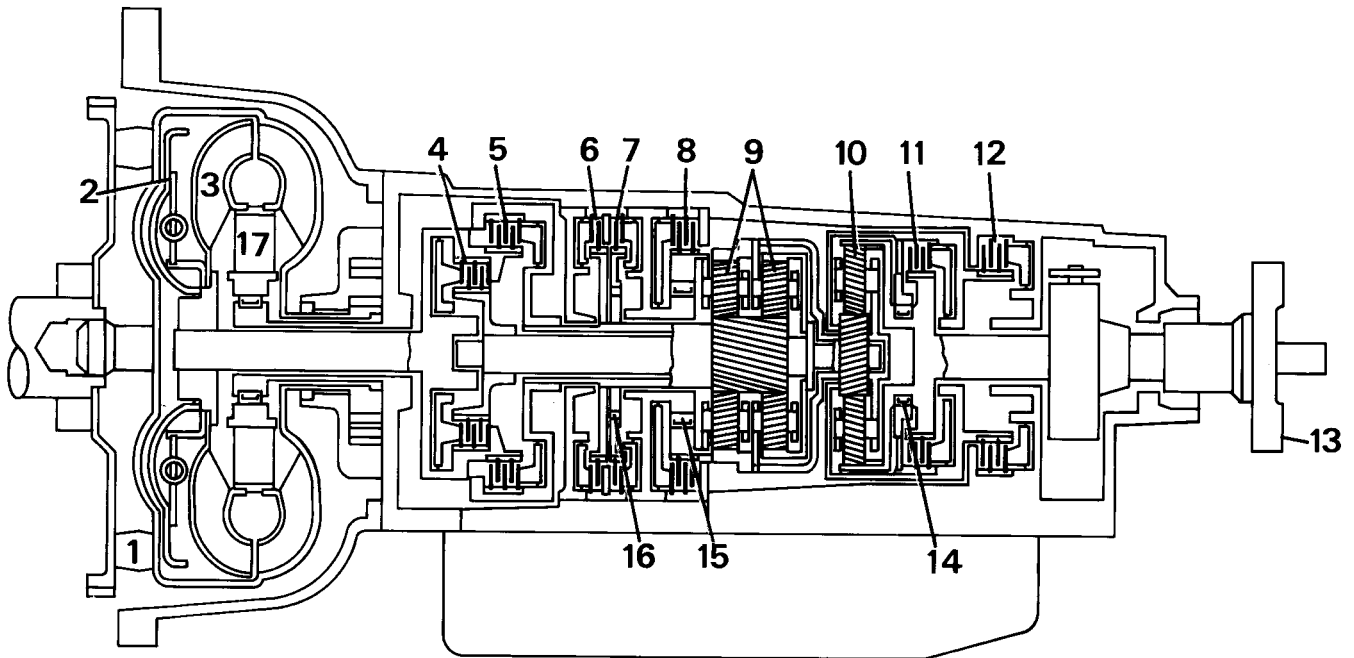

RR3560A

The gear selector has seven positions as follows:

- P = Park provides a mechanical lock on the output shaft.
- R = Reverse gear.
- N = Neutral.
- D = Provides a 1st gear start and automatic shifts 1-2-3-4-3-2-1.
- 3 = Provides a 1st gear start and automatic shifts 1-2-3-2-1.
- 2 = Provides a 1st gear start and automatic shifts 1-2-1 or 3-2-1.
- 1 = Provides a 1st gear start with no up shifts, or 3-2-1.

All automatic shifts are automatically controlled by the valve block and an hydraulic governor driven by the output shaft.

Power flow

1st gear D selected

With D selected 1st gear engaged, clutches 4 and 11 are operative. The front planet gear carrier of gear set 9 is locked against the housing through freewheel 15 when the engine is pulling but freewheels when the vehicle is coasting. Epicyclic gear set 10 rotates as a solid unit with the front planet gear carrier. In selector position 1 with 1st gear engaged, clutch 8 operates to prevent the loss of drive on the overrun through freewheel 15, to provide engine braking.

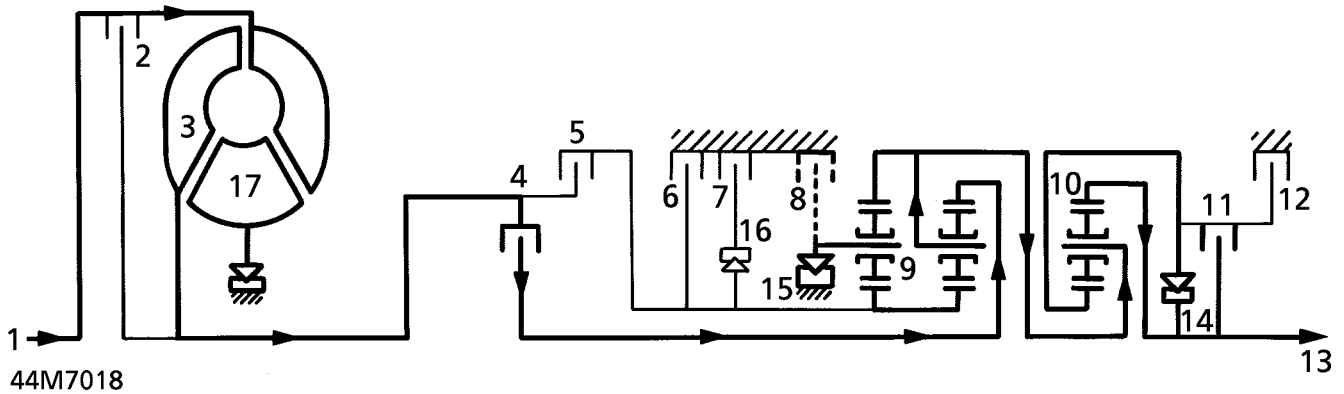

2nd gear D selected

Clutches 4, 6, 7 and 11 are engaged. Freewheel 15 overruns, the hollow shaft with the sun wheel of epicyclic gear set 9 is locked. Epicyclic gear set 10 also rotates as a solid unit.

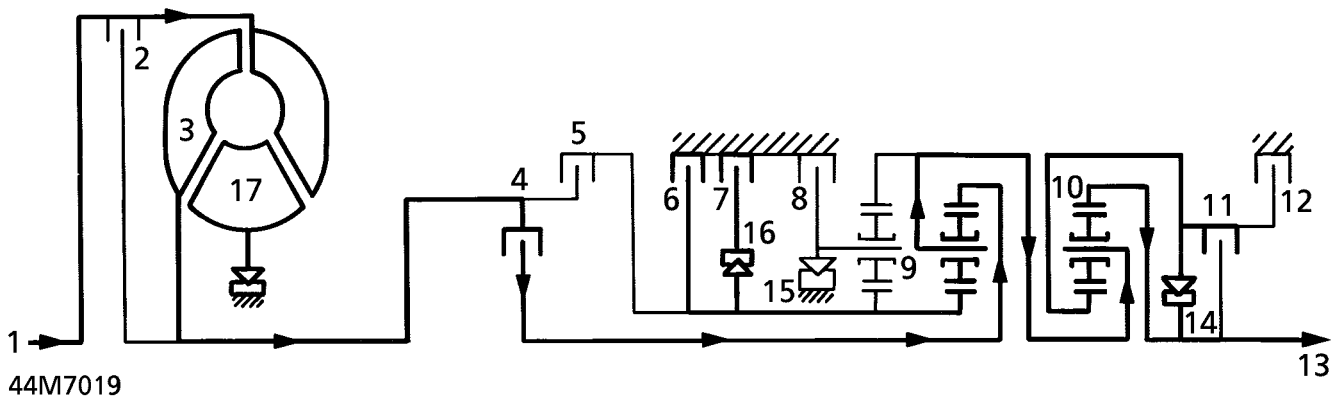



3rd gear D selected

Clutches 4, 5, 7 and 11 are engaged. Freewheel 15 and 16 are overrun. Epicyclic gear set 9 and 10 rotate as a solid unit at a ratio of 1:1.

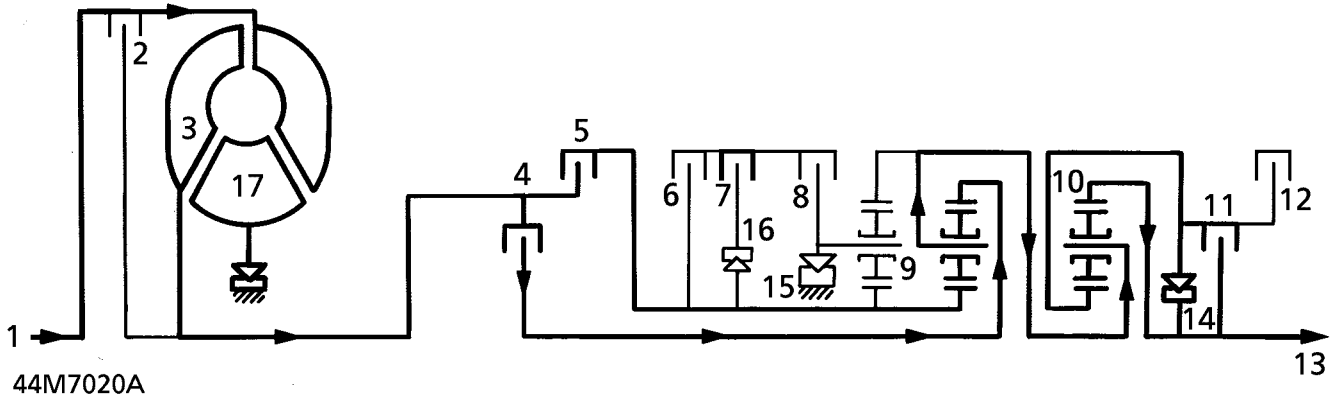

4th gear D selected

Clutches 4, 5, 7 and 12 are engaged. Freewheel 14, 15 and 16 are overrun. Epicyclic gear set 9 rotates as a solid unit. The hollow shaft with the sun wheel of epicyclic gear set 10 is locked.

Above a predetermined road speed, clutch 2 locks the gearbox power input direct to the engine, by-passing the torque converter.

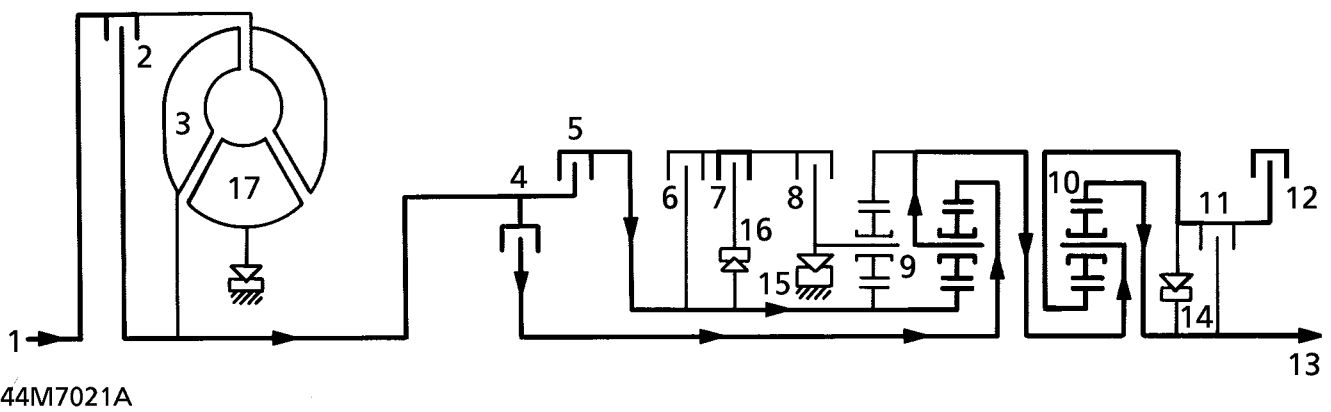

Reverse gear

Clutches 5, 8 and 11 are engaged. Since the front planet gear carrier of epicyclic gear set 9 is locked, the direction of output-shaft rotation is reversed. Epicyclic gear set 10 also rotates as a solid block.

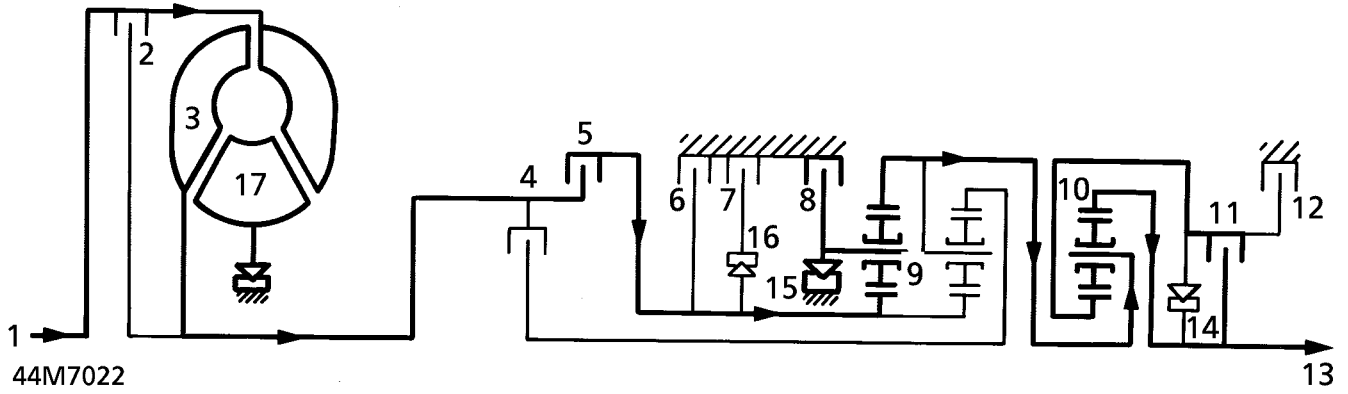



ZF AUTOMATIC GEARBOX

Before referring to fault symptoms, carry out initial static checks first:

INITIAL STATIC CHECKS

Check start positions	'P' & 'N' only
Reverse lights	'R' only
Gear engagements	N-D,N-3,N-2,N-1,N-R
Full throttle	Engine switched off, check full travel at engine and at pedal.
Oil level	'N' selected, engine running at normal running temperature.

Pressure test

2000 rev/min	10 ± 0.3 bar	150 ± 5 lbf/in ²
Idle pressure at 665 to 735 rev/min.	6.9 ± 0.3 bar	100 ± 5 lbf/in ²

To fit pressure gauge

Service tools: See *Service tools, Automatic Gearbox*

Pressure gauge 0 to 20 bar, 0 to 300 lbf/in².
Flexible hose adaptor.

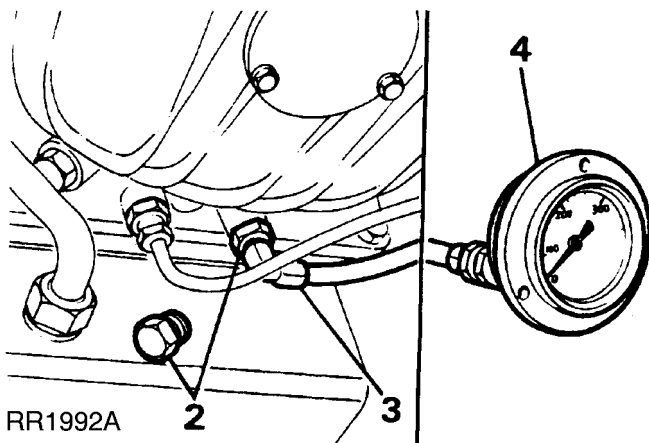

1. Site vehicle on a ramp [hoist].
2. From under gearbox, remove socket head plug (located 10cm, 4 in from oil pipe). Fit hose adaptor **LST502-1**.
3. Fit hose to adaptor.
4. Fit gauge **18G502A** to hose and route into vehicle, ensuring hose is clear of rotating parts and exhaust pipes.
5. Carry out road test. See *Road Test Procedure*
6. Remove pressure gauge

ROAD TEST PROCEDURE

Follow the procedure given commencing each test, from a standing start, on a level road, in good weather conditions.

ROADTEST 1 = CHECKS 1-2-3-4-5-6-7-8**D SELECTED KICKDOWN START FROM REST****CHECK 1**

Check for clutch squeal and slip. Check pressure is 150lbf/in²

CHECK 2

Check 1st to 2nd upshift speed and quality. Pressure should fall to 120 lbf/in².

CHECK 3

Check 2nd to 3rd upshift speed and quality. Pressure should fall to 100 lbf/in²

CHECK 4

Release throttle to allow simultaneous engagement 4th + DDC. Check shift quality and engine rpm drop of approximately 500 rpm.

CHECK 5

To proceed to Check 5, release throttle and check drop out speed of direct drive clutch to 4th.

CHECK 6

Check down shift speed and quality 4th to 3rd.



NOTE: This shift is usually very smooth and difficult to detect.

CHECK 7

Check downshift speed and quality 3rd to 2nd.

CHECK 8

Check downshift speed and quality 2nd to 1st. Also difficult to detect.

ROADTEST 2 = CHECKS 9-10-11**D SELECTED FROM REST****FULL THROTTLE START****CHECK 9**

Check 1st to 2nd upshift speed and quality.

CHECK 10

Check 2nd to 3rd upshift speed and quality.

CHECK 11

Check 3rd, 4th and direct drive clutch upshift speed and quality.



NOTE: 4th and the direct drive clutch engage simultaneously.

**ROADTEST 3 = CHECKS**

12-13-14-15-16-17-18-19-20-21-22-23

D SELECTED FROM REST**LIGHT THROTTLE START****CHECK 12**

Check 1st to 2nd upshift speed and quality.

CHECK 13

Check 2nd to 3rd upshift speed and quality.

CHECK 14

Check 3rd to 4th upshift speed and quality.



NOTE: This shift is usually very difficult to detect but can be confirmed by a 200 rpm drop in engine speed.

CHECK 15

Check speed and quality of shift into direct drive clutch, confirmed by 300 rpm drop in engine speed.



NOTE: An intermediate throttle position engagement of 4th and the direct drive clutch, which is indicated by a fall of 500 rpm in engine speed.

CHECK 16

At approximately 88 kph, 55 mph depress throttle to kickdown - gearbox should change down to 2nd - release throttle to re-engage 4th direct drive clutch continue to accelerate gently.

CHECK 17

At approximately 128 kph, 80 mph depress throttle to kickdown - gearbox should change down to 3rd - release throttle to re-engage 4th direct drive clutch and continue to accelerate gently.

CHECK 18

At approximately 138 kph, 85 mph select 3rd, gearbox should change immediately down to 3rd. Release throttle.

CHECK 19

De-accelerate to approximately 47 kph, 30 mph depress throttle to kickdown - gearbox should downshift to 1st gear, continue accelerating at full throttle until 3rd gear is attained. To do this you will have repeated check 2 of Test 1.

CHECK 20

At 128 kph, 80 mph select 2nd no downshift should occur. Release throttle.

CHECK 21

At 104 kph, 65 mph an automatic downshift into 2nd gear should occur. Continue to de-accelerate.

CHECK 22

At 88 kph, 55 mph select 1st. No downshift should occur. Continue to de-accelerate.

CHECK 23

With 1 selected 2nd gear engaged, continue to de-accelerate and at 45 kph, 28 mph the box should automatically downshift to 1st gear after which no upshifts will occur in this selector position.

END OF ROADTEST

AUTOMATIC GEARBOX ASSEMBLY

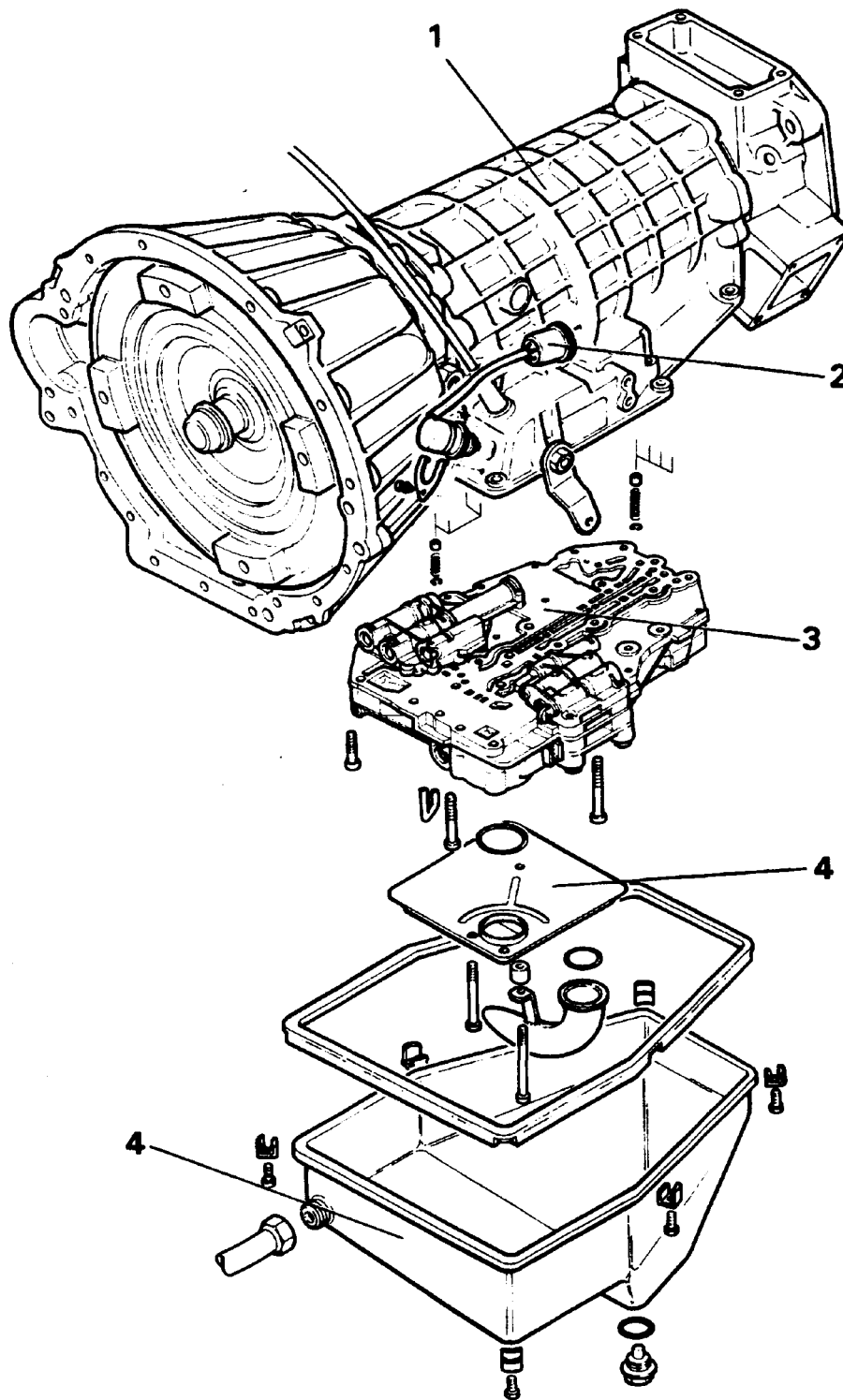

RR0524A

1. Gearbox assembly
2. Inhibitor switch assembly
3. Control unit assembly
4. Filter and sump assembly



1. Torque converter housing assembly
2. Gearbox pump and casing assembly
3. Governor and adaptor housing assembly

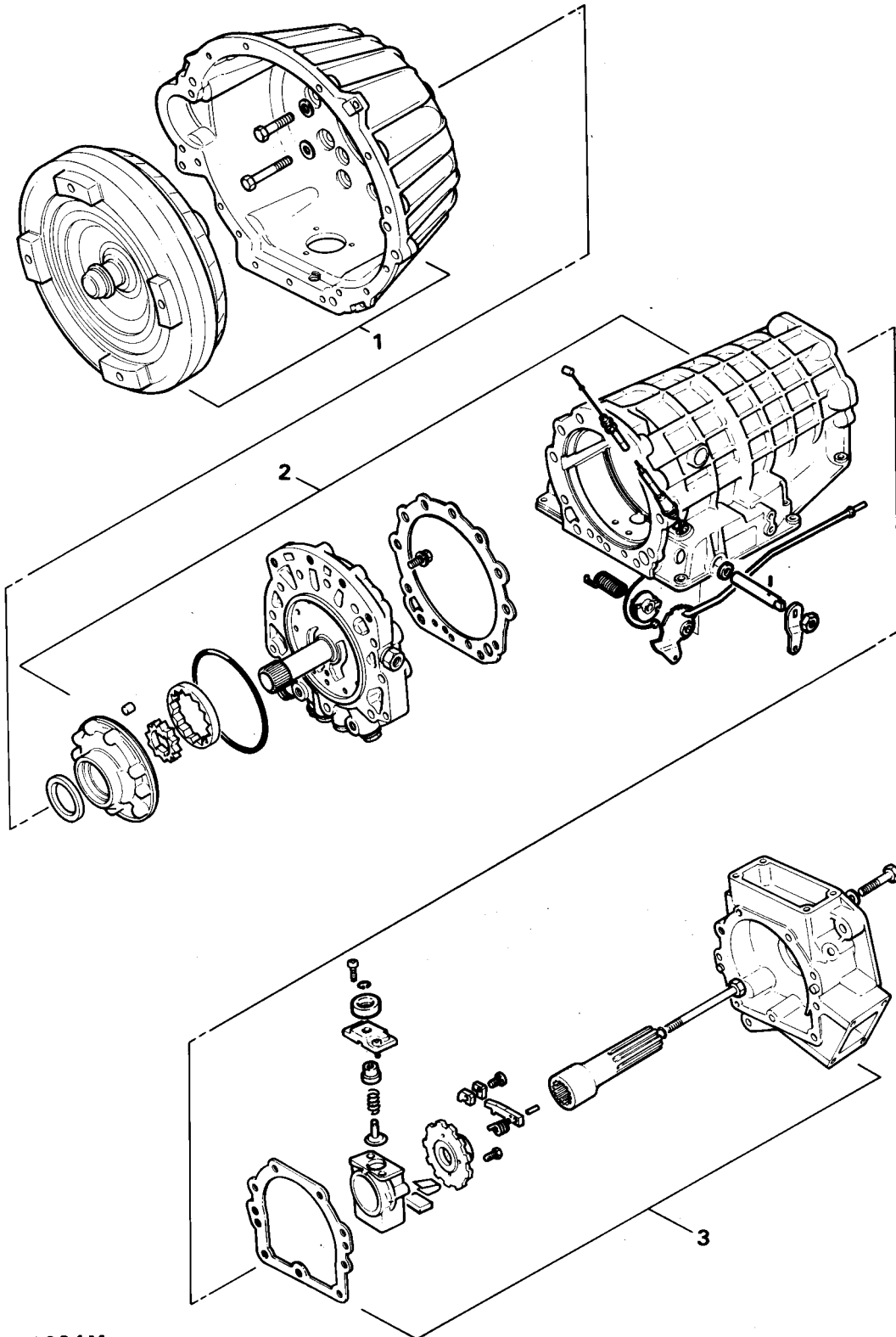

RR 3894M

- 1. A Clutch assembly
- 2. B Clutch assembly

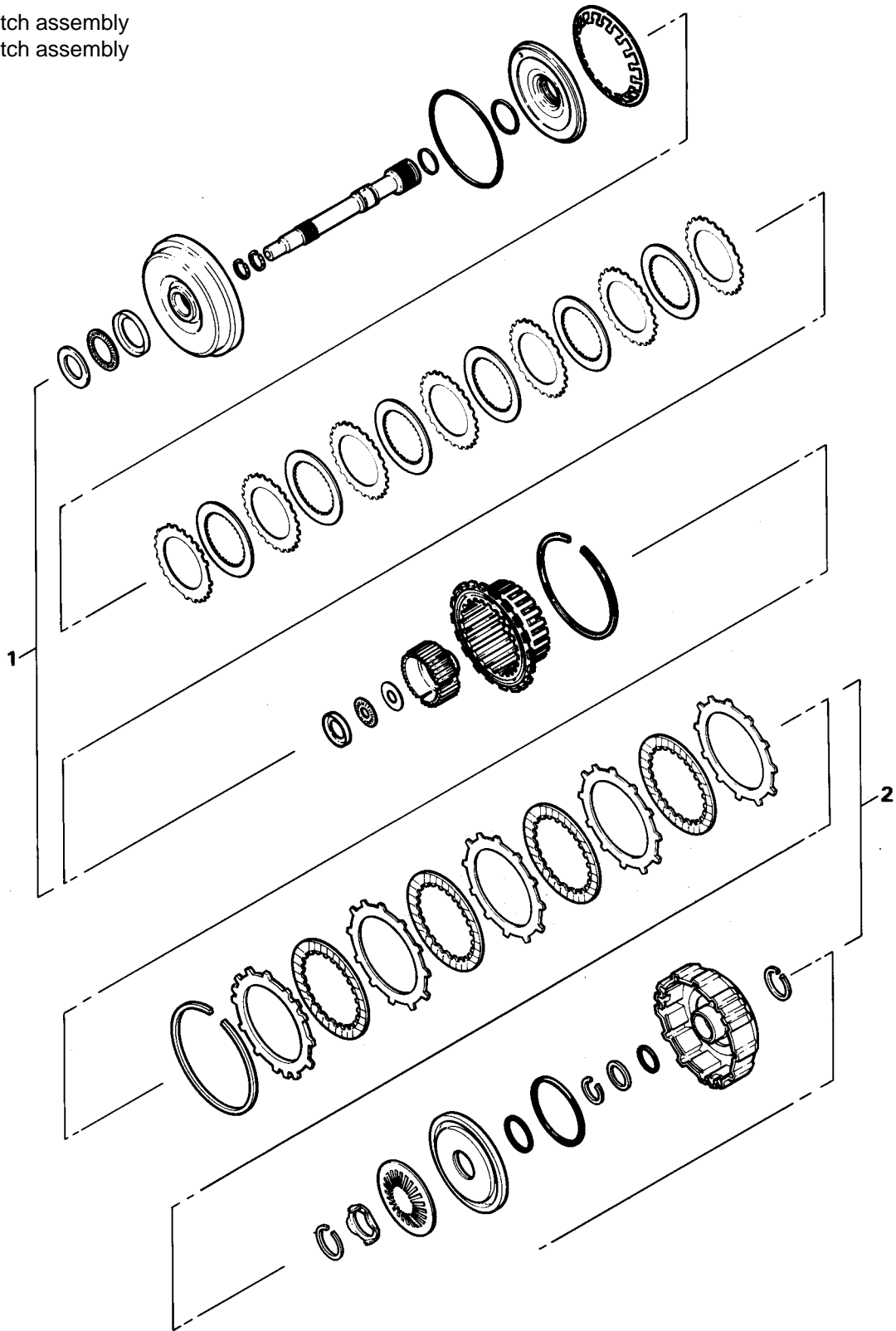

RR3895M



1. C,C' and D Clutch assembly

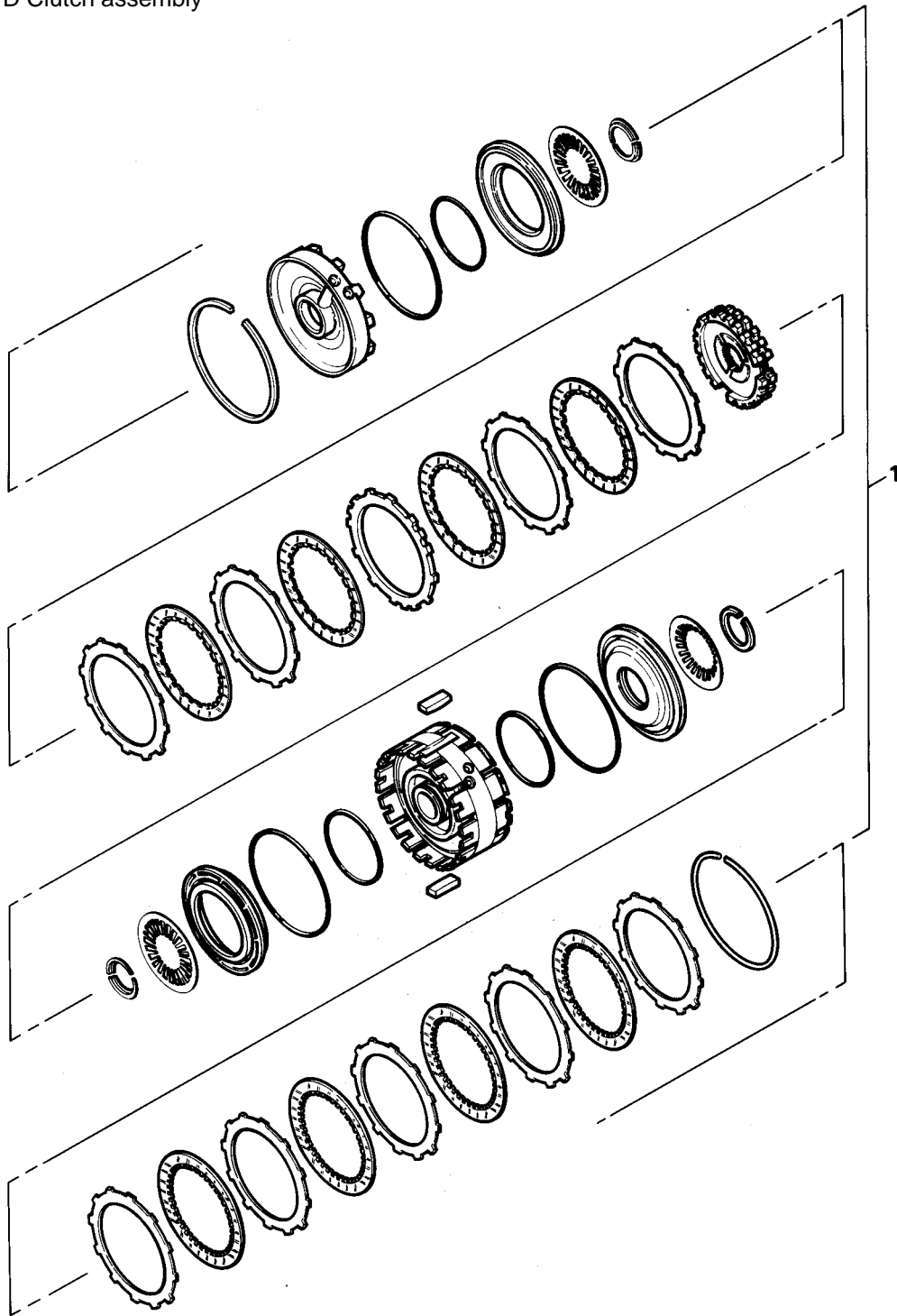

RR3896M

1. Freewheel and fourth gear assembly

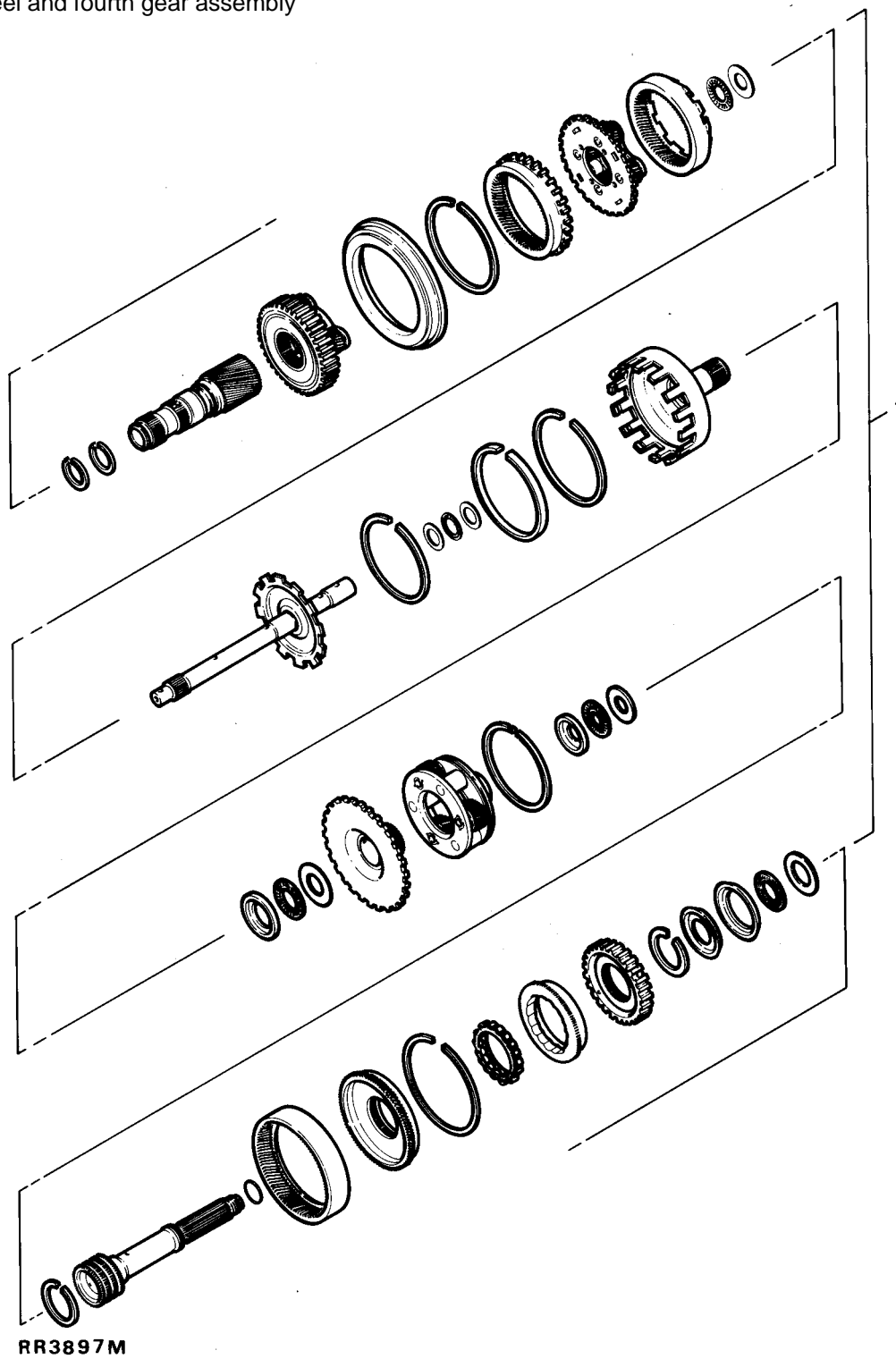



1. E and F Clutch assembly

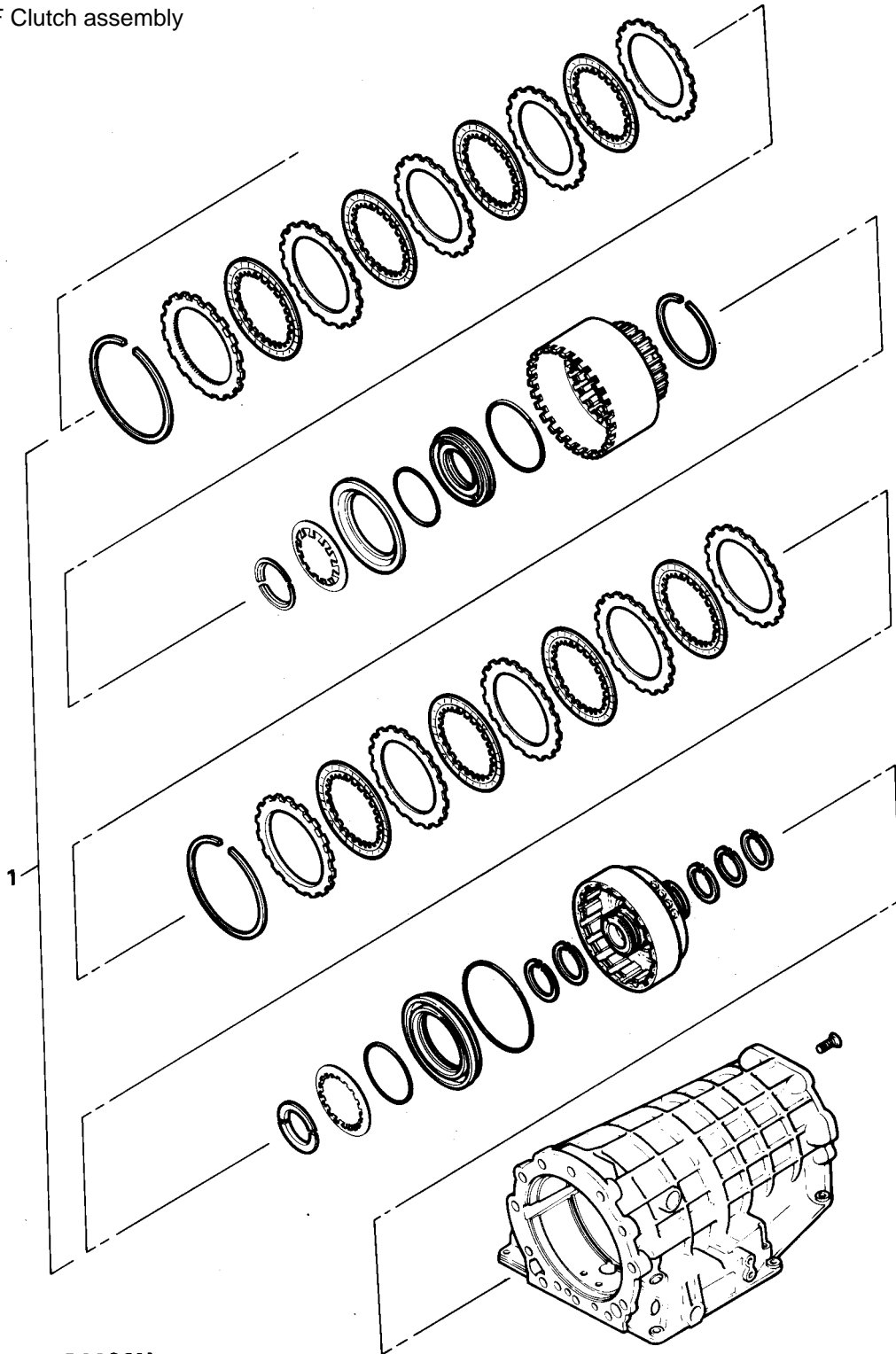

RR3898M

FAULT SYMPTOMS**SYMPTOM 1 - Intermittent drive and high pitched noise**

FAULT - Low fluid level or restricted filter

SYMPTOM 2 - No drive in reverse

Select 'D'

- No drive
FAULT - Continue with Symptom 3
- Drives forward
FAULT - Reverse gear interlock valve seized

Select '1'

- No engine braking
FAULT - Clutch brake 3

SYMPTOM 3 - No drive from rest with 'D' selected

Select '1'

- Vehicle drives
FAULT - No 2 freewheel
- No drive

Carry out main line pressure check

- Normal pressure
FAULT - Clutch A
- No pressure
FAULT - Blocked filter or pump failure
- Low pressure
FAULT - Restricted filter or sticking primary regulator

SYMPTOM 4 - Slip in all forward gears

Carry out main line pressure check

- No pressure
FAULT - Blocked filter or pump failure
- Low pressure
FAULT - Restricted filter or sticking primary regulator
- Normal pressure
FAULT - Clutch 'A'

SYMPTOM 5 - Harsh engagement 'N' to 'D'

Check engine idle speed

Carry out main line pressure check

- High pressure
FAULT - Primary regulator stuck
- Normal pressure
FAULT - Clutch 'A' or damper for clutch 'A'

SYMPTOM 6 - Fierce shift or flare 1st to 2nd shift

Check engine idle speed

Carry out mainline pressure check

- High pressure
FAULT - Continue with symptom 5
- Normal pressure
FAULT - Modulator valve or dampers for clutch brake CB1 and/or clutch brake CB2
FAULT - Clutch brake CB1 and/or clutch brake CB2

SYMPTOM 7 - Fierce shift or flare 2nd to 3rd

Carry out mainline pressure check

- High pressure
FAULT - Continue with symptom 5
- Normal pressure
FAULT - Modulator valve or clutch 'B' damper
FAULT - Clutch 'B'

SYMPTOM 8 - No 3rd gear

FAULT - 2-3 shift valve
FAULT - Clutch 'B'

SYMPTOM 9 - No 4th gear 'D' selected

FAULT - 4th to 3rd downshift valve stuck or 3rd to 4th upshift valve stuck
FAULT - Clutch brake 4



SYMPTOM 10 - None or harsh engagement of direct drive clutch



NOTE: The direct drive clutch will only engage if 4th gear is engaged at 40 to 45 mph.

Carry out road test pressure check with gauge connected to torque converter.

- Normal pressure
 FAULT - Failed direct drive clutch
- Pressures correct but remains high
 FAULTS POSSIBLE -
 Direct drive clutch and torque converter control valve stuck
 Hysteresis valve stuck
 Direct drive clutch control valve stuck

SYMPTOM 11 - Direct drive clutch shift point incorrect or at low speed



NOTE: Direct drive clutch engagement at low speed will cause vibration in the torque converter

Carry out mainline and torque converter pressure check

- Normal pressure
 FAULT - Governor valve sticking
- Low or incorrect pressure
 FAULTS POSSIBLE -
 Direct drive clutch and torque converter control valve sticking.
 Hysteresis valve stuck.
 Direct drive clutch control valve stuck.

SYMPTOM 12 - Drives in 'D' but immediately upshifts to 3rd

FAULT - 2nd to 3rd shift valve stuck.

SYMPTOM 13 - With 'D' selected vehicle starts in 2nd

FAULTS POSSIBLE -
1st and 2nd shift valve stuck.
Governor sleeve sticking.

SYMPTOM 14 - With 'D' selected vehicle starts in 3rd

FAULTS POSSIBLE -
1st to 2nd and 2nd to 3rd shift valves stuck.
Governor sleeve sticking.

SYMPTOM 15 - No kickdown 4th to 3rd

FAULT - 4th to 3rd kickdown valve stuck.

SYMPTOM 16 - Upshifts/downshifts and kickdown shifts at incorrect road speeds

Check throttle kickdown cable adjustment
Carry out main line pressure check

- Normal pressure
 FAULT - Governor valve sticking
- Incorrect pressure
 FAULTS POSSIBLE -
 Incorrect throttle valve adjustment
 Primary regulator sticking

SYMPTOM 17 - No upshifts at light throttle

FAULTS POSSIBLE
Governor valve sticking
Shift valves sticking

SYMPTOM 18 - No engine braking '3' selected 3rd gear

FAULT - Clutch 'C'

SYMPTOM 19 - Delayed or no downshift occurs when making a manual selection from '3' to '2'

FAULTS POSSIBLE -
2nd and 3rd upshift valve sticking.
Governor valve sticking.
'2' Position interlock valve sticking.

SYMPTOM 20 - At speeds below 28 mph when making a manual selection from '2' to '1', downshift is delayed or does not occur

FAULTS POSSIBLE -
Governor sticking.
1st to 2nd shift valve sticking.
'1' Position interlock valve sticking.

SYMPTOM 21 - '1' Selected 1st gear no engine braking

FAULT - Clutch brake 3

SYMPTOM 22 - '2' Selected 2nd gear no engine braking

FAULT - Clutch brake 1

SYMPTOM 23 - Vehicle drives forward in 'N'

FAULT - Clutch 'A' stuck



KICKDOWN CABLE ADJUSTMENT

Service repair no - 44.30.02

1. Release and remove kick-down cable clevis pin.
2. Loosen locknut and release kickdown cable from abutment bracket.
3. Release outer cable sleeve from clip on rear of LH cylinder head.
4. Holding cable as straight as possible, extend inner cable to first detent.

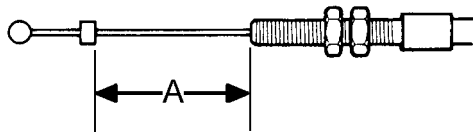

44M1025

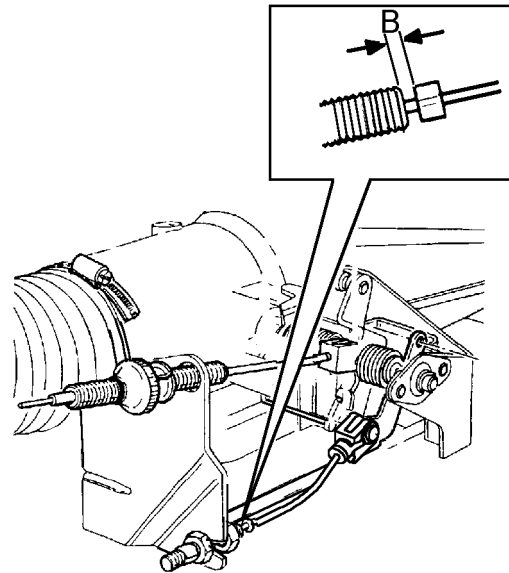

44M1026

5. With inner cable extended, check dimension **A** between end of threads and crimped sleeve.
Dimension **A** = 42 mm \pm 3 mm, 1.65 \pm 0.10 in.
6. Connect cable to abutment bracket and fit locknut.
7. Secure outer cable sleeve to clip on rear of LH cylinder head.
8. Connect kick-down cable to throttle lever and secure with clevis pin.
9. Adjust outer cable until crimped sleeve is dimension **B** from end of outer cable.
Dimension **B** = 1 mm, 0.04 in.
10. Tighten locknut.



KICKDOWN CABLE

Service repair no - 44.15.01

Remove

1. Site vehicle on a four post ramp [hoist].
2. Select neutral 'N'.
3. Disconnect battery negative lead.

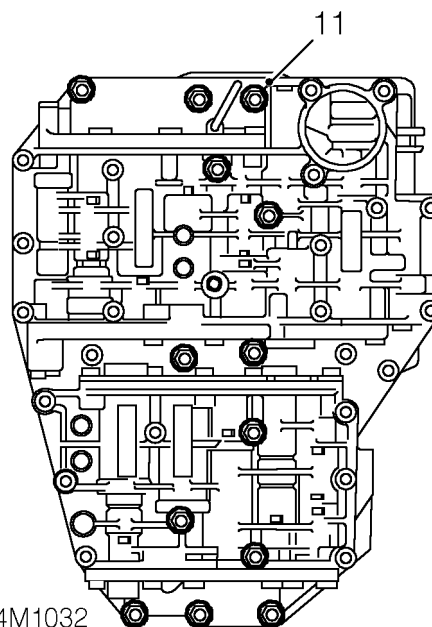
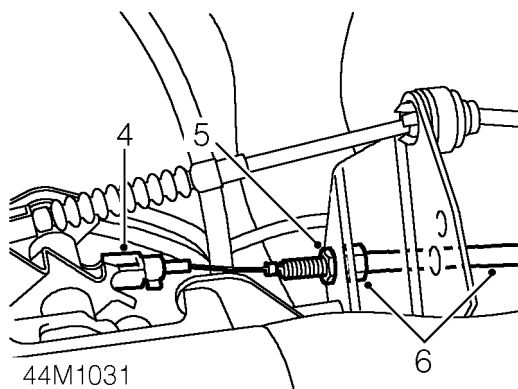

4. Remove clevis pin and release kickdown cable at throttle linkage.
5. Release outer cable locknut.
6. Disconnect cable from abutment bracket.
7. Release cable from retaining clip at bracket attached to cylinder head.
8. Feed cable through to underside of vehicle.
9. Raise vehicle on ramp [hoist].
10. Remove gearbox fluid pan **See Fluid pan gasket and screen.**
11. Remove 13 bolts securing control unit assembly to gearbox.
12. Rotate accelerator cam and release nipple of kickdown inner cable from cam.
13. Using special tool **LRT-44-004**, compress cable tangs and remove cable from gearbox.
14. If cable is to be refitted, remove 'O' ring seal and clean cable assembly.

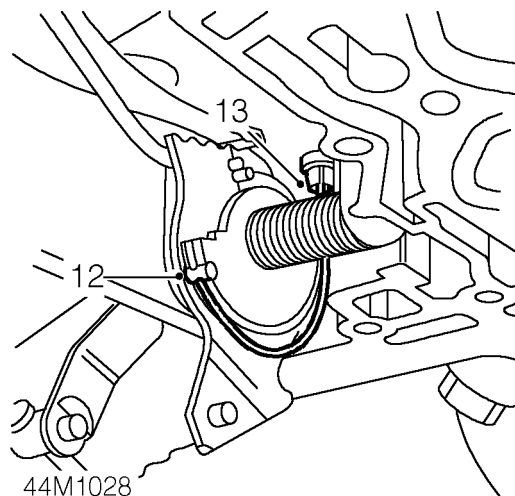

Refit

15. Fit NEW 'O' ring seal to cable and lubricate seal.
16. Fit cable to gearbox casing ensuring it is correctly seated.
17. Spring load cam by turning once and fit inner cable nipple into cam seat.

18. Ensuring cable nipple remains engaged, feed free end of cable assembly into engine compartment.
19. Locate control unit assembly to gearbox and loosely fit 13 bolts. Ensure selector shaft locates into gear shift fork.



NOTE: When a new cable is fitted, to help locate nipple to cam, introduce a curve into the cable. DO NOT bend or kink cable.

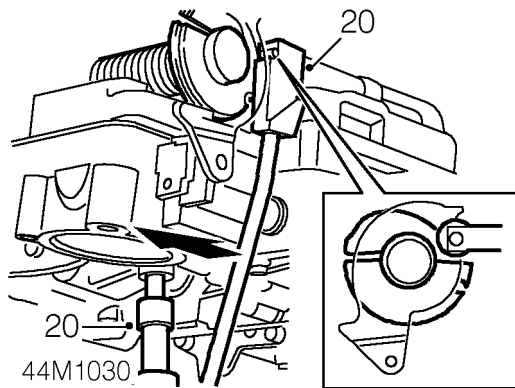

20. Locate selector linkage setting gauge **LRT-44-002** in position and gently press control unit forwards as shown. Tighten bolts to **8 Nm, 6 lbf ft.**
21. Remove setting gauge.
22. Refit gearbox fluid pan *See Fluid pan gasket and screen.*
23. Lower vehicle on ramp [hoist].
24. Adjust kickdown cable *See Adjustment, Kickdown cable adjustment.*
25. Reconnect battery negative lead.
26. Refill gearbox oil using correct grade of oil *See LUBRICANTS, FLUIDS AND CAPACITIES, Information, Recommended Lubricants and Fluids.*

INHIBITOR SWITCH

Service repair no - 44.15.19

Remove

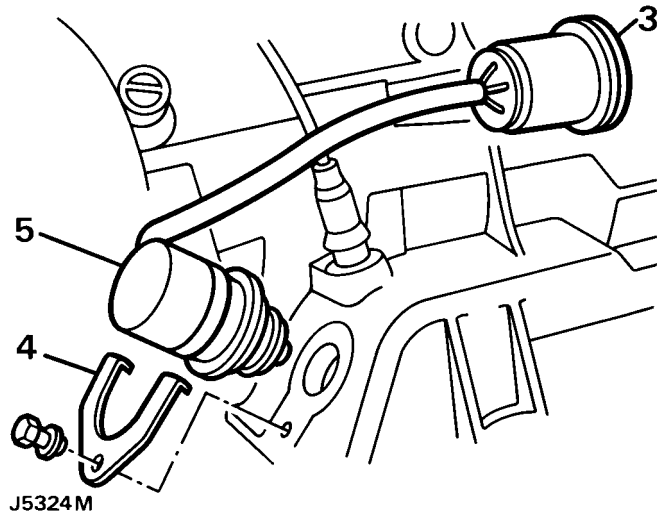

1. Site vehicle on a four post ramp [hoist].
2. Disconnect battery negative lead. Raise vehicle.
3. Disconnect inhibitor switch multiplug.
4. Remove inhibitor switch retaining plate.
5. Remove inhibitor switch.
6. Remove 'O' ring seal.
7. Clean inhibitor switch.

Refit

8. Clean mating face on casing.
9. Fit and lubricate NEW 'O' ring seal to switch.
10. Fit switch to casing.
11. Secure with retaining plate and bolt.
12. Connect multiplug to harness.
13. Reconnect battery and remove vehicle from ramp [hoist].



FLUID PAN GASKET AND SCREEN

Service repair no - 44.24.05 - Fluid pan gasket

Service repair no - 44.24.07 - Fluid screen

Remove

1. Site vehicle on a four post ramp [hoist].
2. Disconnect battery negative lead.
3. Raise vehicle.
4. Drain fluid and refit plug with new seal. Tighten to **43 Nm, 32 lbf ft.**
5. Remove catalytic converter assembly *See EMISSION CONTROL, Repair, Front pipe/catalytic converter.*

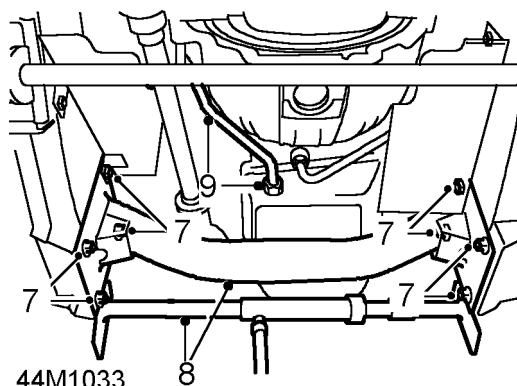

6. Release fuel pipes from retaining clip secured by top RH chassis crossmember bolt.
7. Remove 8 bolts securing chassis crossmember.
8. With assistance and using a body jack between chassis longitudinals, jack chassis sufficiently to enable removal of crossmember.
9. Disconnect dipstick tube from fluid pan. Loosen securing bolt at bell housing and move tube aside.
10. Remove clamps securing fluid pan. Note their locations for refit and withdraw pan.
11. Remove gasket and clean gasket mating faces.
12. Remove securing screws and detach oil screen and suction pipe, taking care to retain suction pipe spacer, discard 'O' ring seal.
13. Detach suction pipe from fluid screen, discard 'O' ring seal.

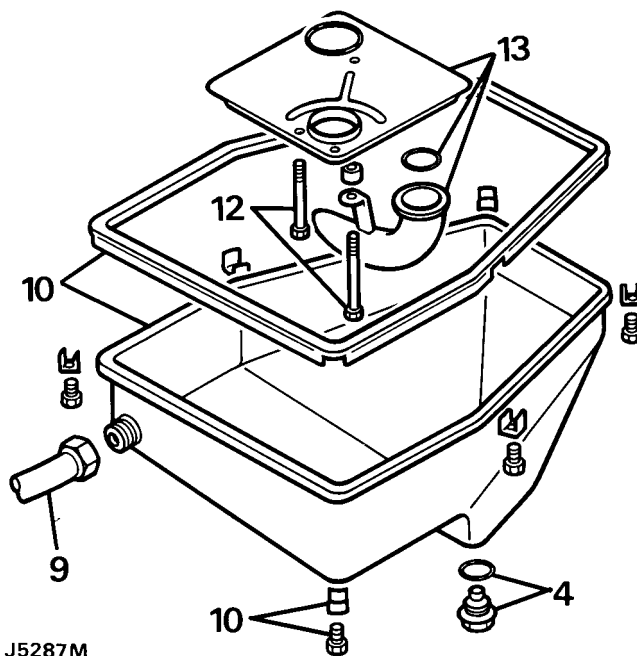

Refit

14. Clean fluid screen and blow out with airline.
15. Clean suction pipe.
16. Fit new 'O' ring seals to fluid screen using light grease to aid assembly.
17. Fit fluid screen and suction pipe with spacer and secure with bolts. Tighten to **8 Nm, 6 lbf ft.**
18. Refit fluid pan using a NEW gasket. Tighten to **8 Nm, 6 lbf ft.**
19. Connect dipstick tube to fluid pan, tighten bolt at bell housing. Filler tube union nut Tighten to **70 Nm, 52 lbf ft.**
20. Position both exhaust heat shields and refit chassis cross-member. Secure fuel pipes to retaining clip.
21. Refit catalytic converter assembly *See EMISSION CONTROL, Repair, Front pipe/catalytic converter.*
22. Connect battery.
23. Refill transmission using correct grade of fluid *See LUBRICANTS, FLUIDS AND CAPACITIES, Information, Recommended Lubricants and Fluids.*
24. Apply parking brake and with selector at 'P', run engine at idle.
25. Apply footbrake, from 'P', move selector to position '1' and back to 'N'. Check fluid level, this must be between the level marks. Top-up as necessary.

TORQUE CONVERTER

Service repair no - 44.17.04

Remove

1. Remove gearbox and transfer box assembly, *See Gearbox and transfer box assembly*

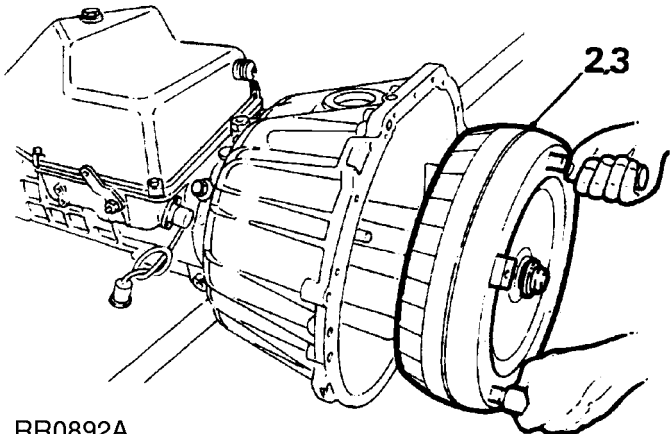

RR0892A

2. Place gearbox on bench. Remove torque converter using torque converter handle **LRT-44-010**, taking care not to damage torque converter/oil pump housing oil seal.

Refit

3. Fit NEW torque converter using torque converter handles **LRT-44-010**. Check dimension from converter fixing boss to converter housing face is 50 mm, 1.968 in. This shows converter is correctly seated in housing.
4. Refit gearbox and transfer box assembly. *See Gearbox and transfer box assembly*

PUMP AND MAIN HOUSING

Service repair no - 44.20.11 - Intermediate plate gasket

Service repair no - 44.32.01 - Pump assembly

Service repair no - 44.32.07 - Pump oil seal

Remove

1. Remove gearbox and transfer box assembly, *See Gearbox and transfer box assembly*
2. Place gearbox on bench. Remove torque converter using torque converter handles **LRT-44-010**, taking care not to damage torque converter/oil pump housing oil seal.

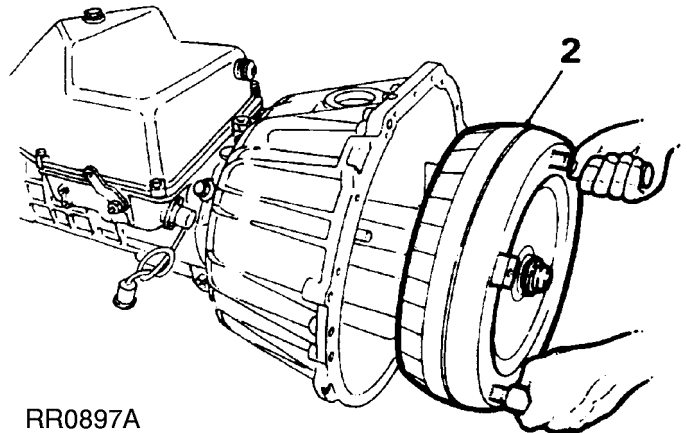

RR0897A

3. Remove 12 bolts (inner ring of bolts).

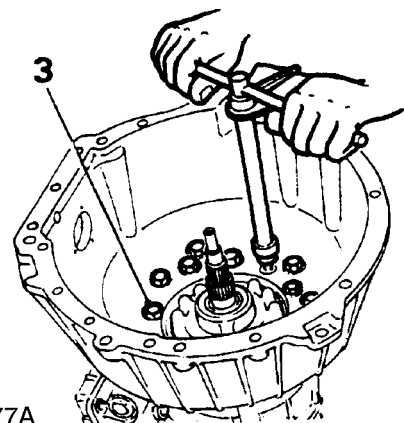

RR0577A

4. Remove bell housing and pump assembly, discard gasket.
5. Remove 8 bolts from rear of pump.



6. Screw in 2 bolts, diagonally opposite each other. Tap lightly using a soft headed mallet to remove pump assembly from intermediate plate.

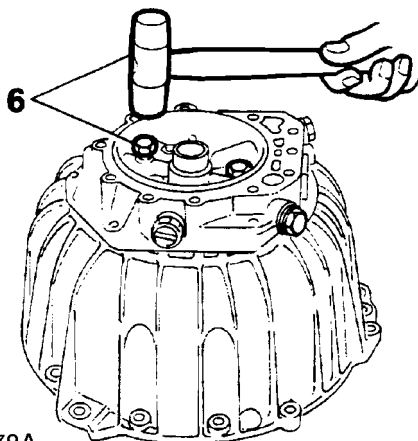

RR0578A

17. Refit torque converter into housing using torque converter handles **LRT-44-010**. Check that dimension from converter fixing bolt boss to converter housing face is 50 mm, 1.968 in to confirm that converter is properly seated in housing.
18. Refit gearbox/transfer box assembly. **See Gearbox and transfer box assembly**

7. Remove shaft sealing ring and 'O' ring from pump housing and discard.

Refit

8. Using oil seal replacer **LRT-44-001** fit shaft seal ring into pump housing.
9. Fit 'O' ring onto circumference of pump housing.
10. Align dowel with hole in intermediate plate and press pump housing home.
11. Fit pump housing to intermediate plate, tighten bolts to **10 Nm, 7 lbf ft.**
12. Place bell housing and intermediate plate assembly on bench, front face up. Using oil pump rotation sleeve **LRT-44-003**(LST111), check that pump gears rotate freely.
13. Before fitting intermediate plate and bell housing assembly, check that thrust washer and axial cage are seated on clutch housing.
14. Place NEW gasket and selective disc washer onto bell housing and intermediate plate assembly using Petroleum Jelly.
15. Fit bell housing and intermediate plate assembly to gearcase. Tighten bolts to **46 Nm, 34 lbf ft.**
16. Place end float gauge **LRT-44-003** onto pump housing and check that axial play is between 0.2 - 0.4 mm, 0.008 - 0.016 in. Replace existing washer, situated at rear of intermediate plate, with a washer selected to give required end float.

GEARBOX AND TRANSFER BOX ASSEMBLY

Service repair no - 44.20.04/99

Remove

1. Position vehicle on '4-post' ramp.
2. Select LOW range gear and leave vehicle in neutral.
3. Disconnect battery negative lead.
4. Drain gearbox oil. **See SECTION 10, Maintenance, under vehicle maintenance**
5. Drain transfer gearbox oil. **See SECTION 10, Maintenance, under vehicle maintenance**
6. Remove centre console. **See CHASSIS AND BODY, Repair, centre console**

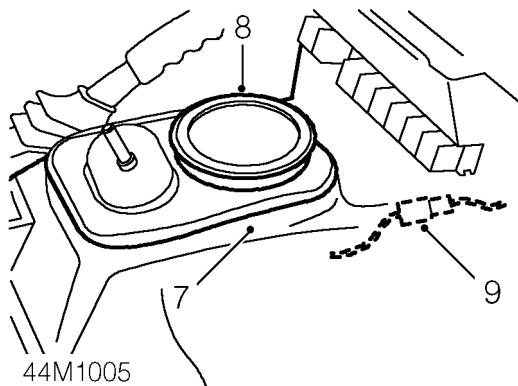

7. Remove carpet from transmission tunnel.
8. Remove hi-low selector housing cover from tunnel.
9. Working through hi-low gear lever aperture, disconnect inhibitor/reverse light switch multiplug.
10. Remove 2 cable ties securing gearbox and transfer box breather pipes to harness.

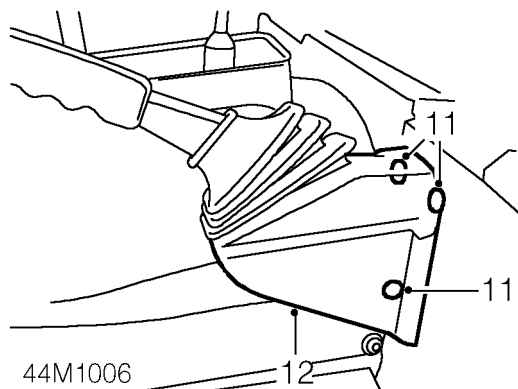

11. Remove 3 trim studs securing hand brake gaiter.
12. Release hand brake gaiter to access cable linkage.

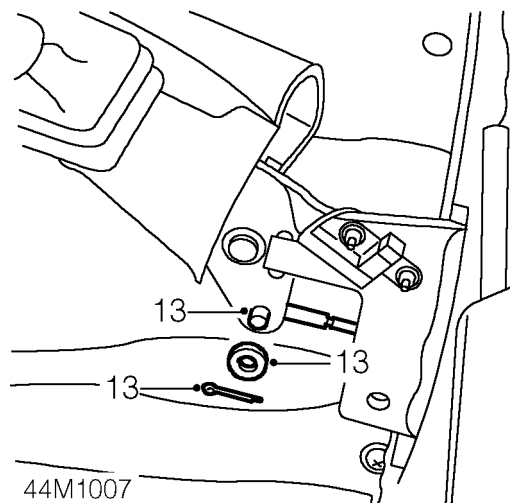

13. Remove split pin and clevis pin securing hand brake cable to lever.

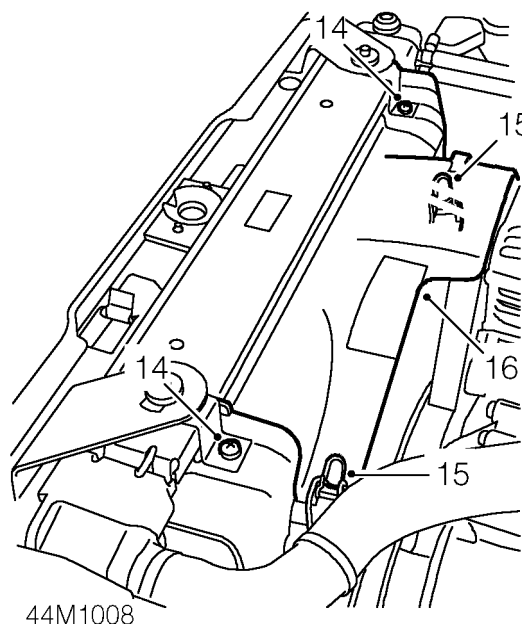

14. Remove 2 screws securing fan cowl to upper retaining brackets.
15. Release 2 clips securing upper fan cowl.
16. Remove upper fan cowl.

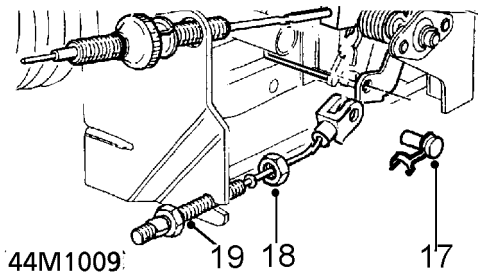

44M1009: 19 18 17

- 17. Remove kick-down cable clevis pin.
- 18. Release kick-down outer cable lock nut.
- 19. Release kick-down outer cable from abutment bracket.
- 20. Release kick-down outer cable from clip on rear of LH cylinder head.

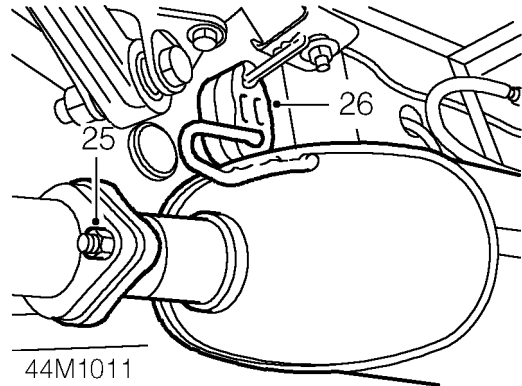

44M1011

- 25. Remove 2 nuts securing intermediate pipe to tail pipe.
- 26. Release intermediate pipe from tail pipe and remove from mounting.

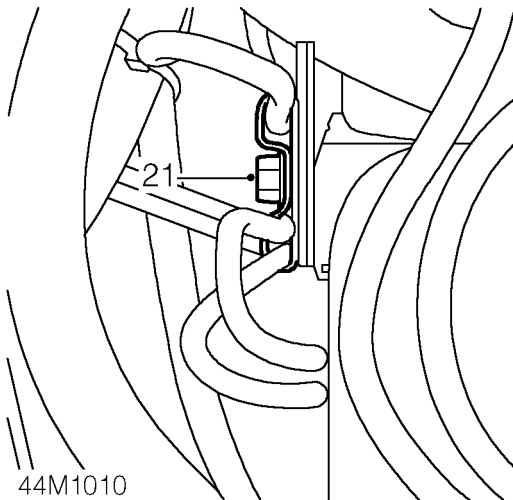

44M1010

- 21. Remove bolt securing 2 breather pipe 'P' clips to rear of RH cylinder head.
- 22. Remove 6 bell housing to engine bolts.
- 23. Raise vehicle.
- 24. Remove exhaust front pipe. **See EMISSION CONTROL, Repair, front pipe/catalytic converter**

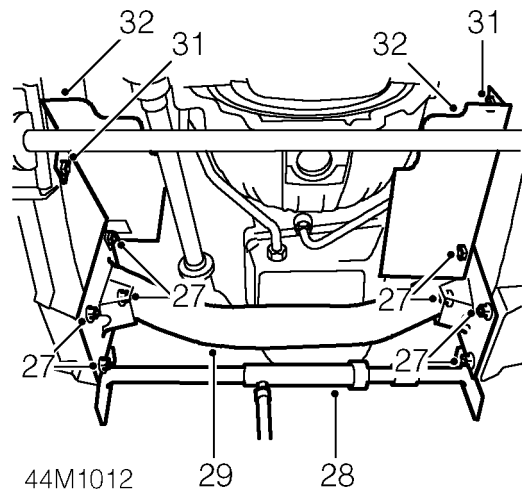

44M1012

- 27. Remove 8 bolts securing chassis crossmember.
- 28. With assistance, and using a body jack between chassis longitudinals, jack chassis sufficiently to enable removal of crossmember.
- 29. Remove crossmember.
- 30. Remove body jack.
- 31. Remove bolt securing LH and RH catalyst heat shields to chassis.
- 32. Remove catalyst heat shields.

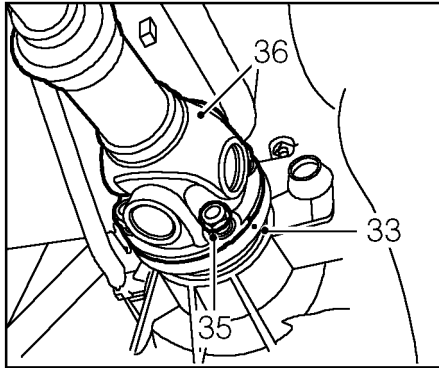

44M1013

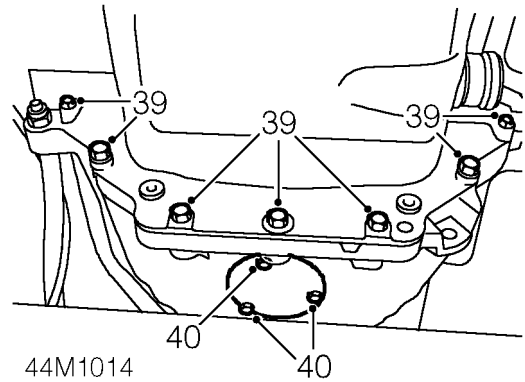
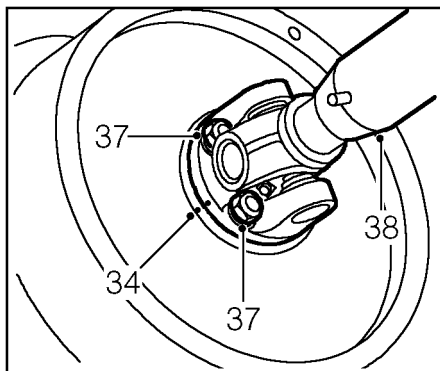

44M1014

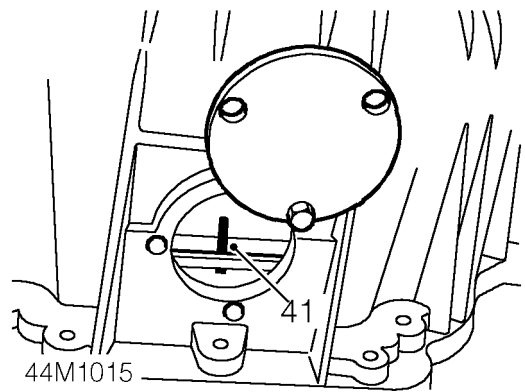

44M1015

- 33. Using a centre punch, mark relationship between front propeller shaft to transfer box flanges.
- 34. Using a centre punch, mark relationship between rear propeller shaft to brake drum flanges.
- 35. Remove 4 nuts securing front propeller shaft to transfer box flange.



NOTE: Rotate propeller shaft to gain access to all fixing.

- 36. Release propeller shaft from transfer box flange bolts and tie aside.
- 37. Remove 4 nuts securing rear propeller shaft to brake drum flange.



NOTE: Rotate propeller shaft to gain access to all fixing.

- 38. Release propeller shaft from brake drum bolts and tie aside.
- 39. Remove 7 bolts securing bell housing closing plate and remove plate.
- 40. Remove 3 bolts securing bell housing access plate and remove plate.

- 41. Mark relationship between converter and drive plate.
- 42. Rotate crankshaft to access drive plate to converter fixing.

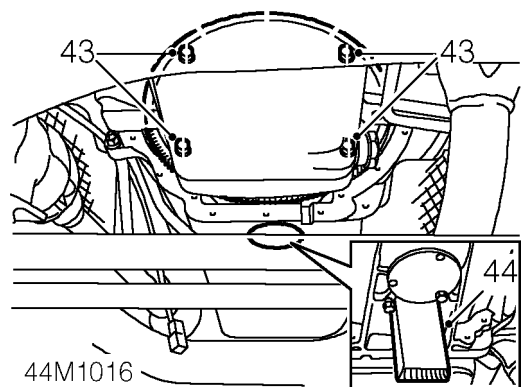

44M1016

- 43. Remove 4 bolts securing drive plate to converter.
- 44. Fit suitable piece of wood through bell housing access hole to retain converter.

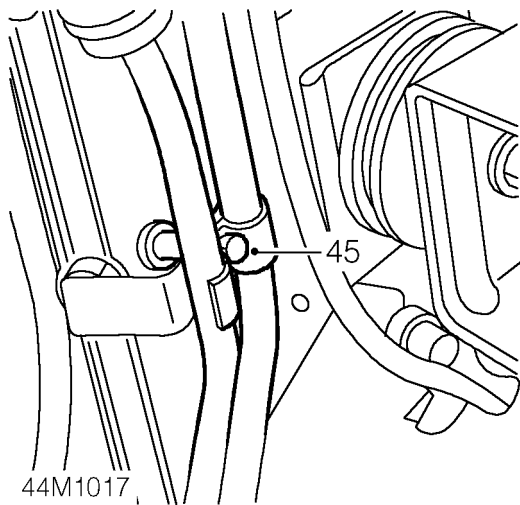

- 45. Remove clamp bolt securing gearbox cooler pipes to engine sump bracket.

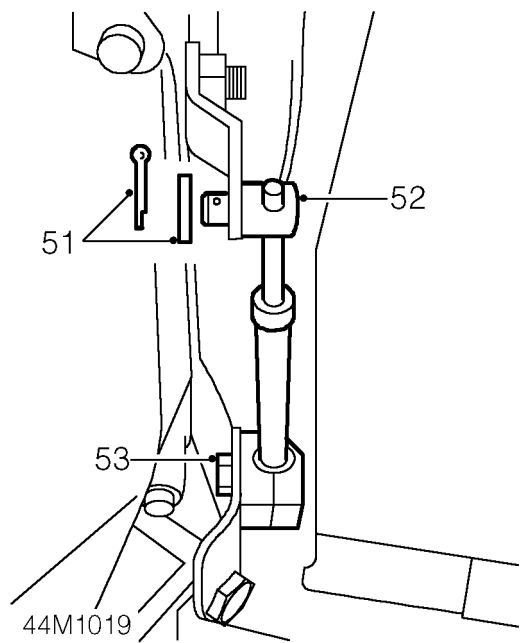

- 51. Remove split pin from selector cable yoke and collect washer.
- 52. Release yoke from lever.
- 53. Remove bolt securing selector outer cable clamp to transfer box LH mounting.

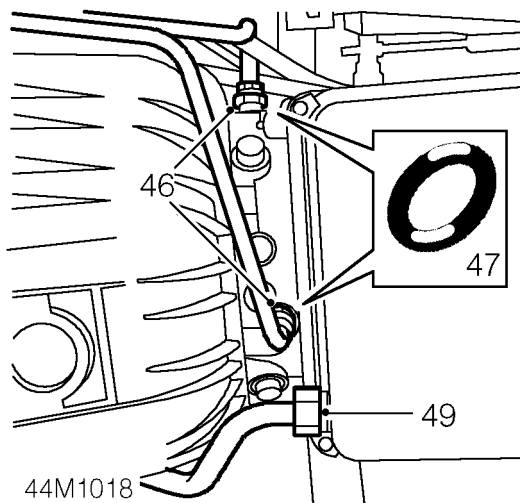

- 46. Loosen gearbox cooler pipe unions and disconnect from gearbox.
- 47. Remove and discard 'O' rings from pipes.

CAUTION: Plug the connections.



- 48. Tie cooler pipes aside.
- 49. Loosen gearbox filler tube union and remove from fluid pan.
- 50. Remove and discard 'O' ring from union.

CAUTION: Plug the connections.

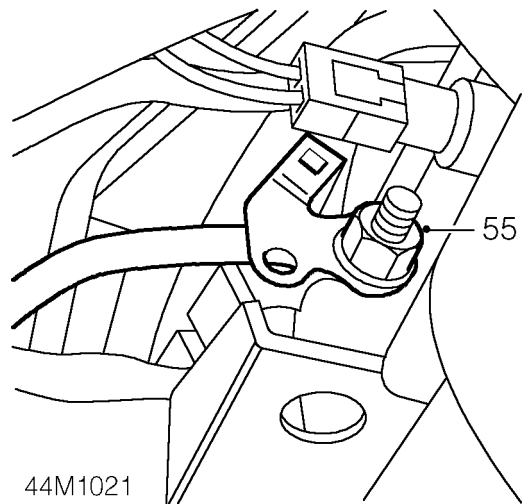

- 54. Remove nut securing oxygen sensor multiplug bracket from transfer box earth bolt and collect bracket.
- 55. Remove nut securing earth strap to transfer box and release strap.

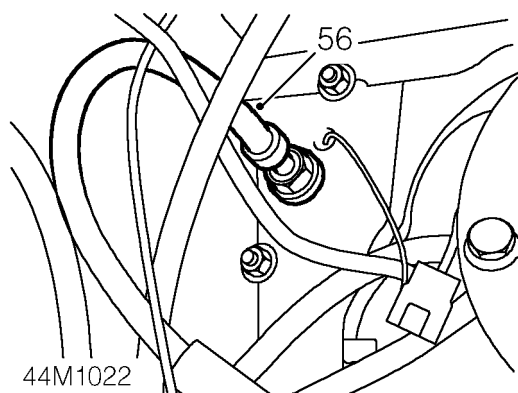

56. Release hand brake outer cable from body.

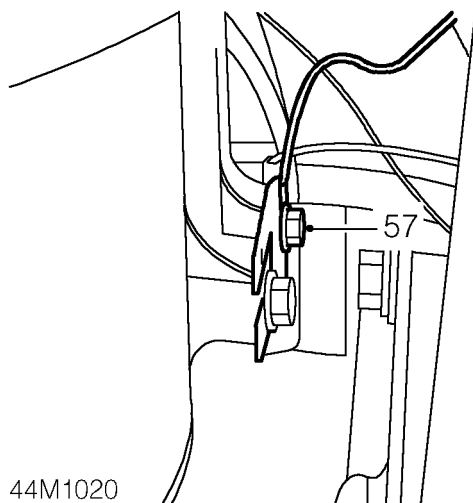

57. Remove bolt securing earth lead to RH side of transfer box.
 58. Fit transmission cradle **LRT-99-008A** to transmission jack.
 59. Fit and tighten bolts securing cradle to jack.
 60. Remove 2 lower bolts securing transfer box rear cover.
 61. Collect hand brake cable heat shield.
 62. Raise jack and align cradle to transmission.
 63. Refit previously removed transfer box rear cover bolts to secure cradle.

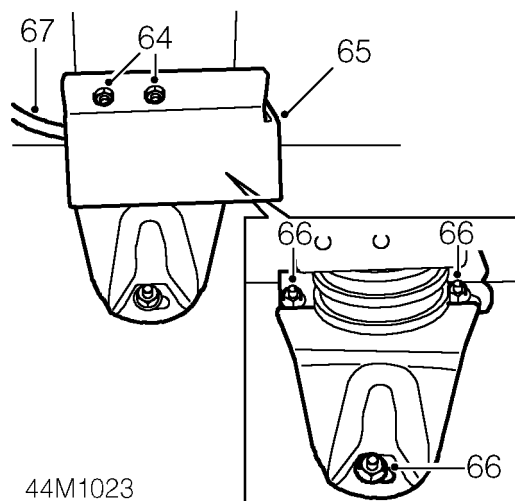

64. Remove 2 nuts and bolts securing heat shield to transfer box LH mounting bracket.
 65. Remove heat shield.
 66. Remove 3 nuts and bolts securing transfer box LH mounting bracket to chassis.
 67. Release earth lead from fixing.

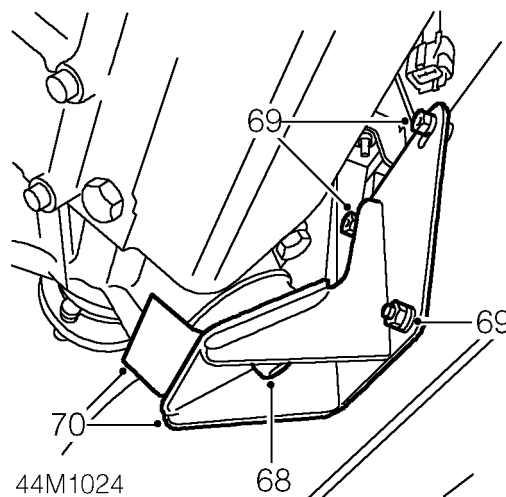

68. Remove nut securing transfer box RH mounting.
 69. Remove 3 nuts and bolts securing transfer box RH mounting bracket to chassis.
 70. Remove transfer box RH mounting bracket and collect flexible mount heat shield.
 71. Lower transmission on jack to access harness connectors.



72. Disconnect the following multiplugs/connectors from transfer box:
Speed transducer
Parking solenoid
Neutral detection switch
Differential lock
Temperature sensor switch
73. Remove 2 cable ties securing harness to transfer box.
74. Position jack to support engine sump.



CAUTION: Use a block of wood or hard rubber pad to protect sump.

75. Remove 2 remaining bell housing to engine bolts.
76. With assistance, lower transmission and engine jacks until hi-low selector lever is clear of transmission tunnel aperture.
77. Separate transmission from engine and lower on jack.
78. Remove transmission assembly from beneath ramp.
79. Position lifting eyes to transmission and secure with bolts.
80. Fit lifting chains to eyes and connect.
81. Position lifting hoist and connect lifting chains.
82. Raise hoist until chains are taught.
83. Remove bolts securing cradle to transfer box.
84. Raise transmission from cradle.
85. Refit transfer box rear cover plate bolts.
86. Lower transmission assembly onto work bench.
87. Disconnect lifting chains from eyes.
88. Remove bolts securing eyes to transmission and remove eyes.

Refit

89. Position lifting eyes to transmission and secure with bolts.
90. Connect lifting chains to eyes.
91. Raise transmission assembly from bench and position above transmission cradle.
92. Remove 2 transfer box rear cover plate bolts.
93. Lower transmission onto cradle, align to transfer box rear cover plate and secure with previously removed bolts.
94. Lower hoist and disconnect lifting chains from eyes.
95. Remove chains from hoist.
96. Remove bolts securing lifting eyes to transmission and remove eyes.



NOTE: Do not fully raise transmission at this stage as access is required for connection of connectors to transfer box.

97. Position transmission assembly beneath vehicle.
98. Clean engine to gearbox mating faces.
99. Clean engine to gearbox dowels and dowel holes.
100. With assistance, raise transmission on jack and position to engine dowels.
101. Fit 2 lower bell housing to engine bolts and tighten to **45 Nm, 33 lbf ft.**
102. With assistance, raise engine and transmission jacks to position transmission assembly.



NOTE: Position earth lead to mounting fixing.

103. Remove engine jack from beneath vehicle.
104. Secure harness to transfer box with cable ties.
105. Connect multiplugs/connectors to transfer box.
106. Raise transmission and align to mounting locations.
107. Fit transfer box RH flexible mounting heat shield and mounting bracket.
108. Align RH mounting to chassis and secure with nuts and bolts.
109. Fit and tighten nut securing RH mounting.
110. Align LH mounting to chassis and secure with nuts and bolts.



NOTE: Position heat shield to cover plate fixing.

111. Position heat shield to LH mounting bracket and secure with fixings.
112. Remove bolts securing transmission cradle to transfer box.
113. Lower transmission jack and remove from beneath ramp.
114. Fit and tighten transfer box rear cover bolts.



NOTE: Apply a soap solution to aid fitment of cable to body.

115. Position earth lead to RH side of transfer box and secure with bolt.
116. Feed hand brake outer cable through body.
117. Position earth strap to transfer box stud and secure with nut.
118. Fit oxygen sensor multiplug bracket to transfer box earth bolt and secure with nut.

- 119. Position selector outer cable clamp to transfer box LH mounting and secure with bolt.
- 120. Position selector cable yoke to lever, fit washer and secure with split pin.
- 121. Remove plug from transmission filler tube union.
- 122. Lubricate new 'O' ring with gearbox oil and fit to filler tube.
- 123. Fit filler tube to gearbox and tighten union.
- 124. Release cooler pipes and remove plugs from connections.
- 125. Lubricate new 'O' rings with gearbox oil and fit to pipes.
- 126. Position cooler pipes to gearbox and tighten unions.
- 127. Position cooler pipes to engine sump bracket, fit clamp and secure with bolt.
- 128. Remove piece of wood from bell housing access hole.
- 129. Align converter to drive plate.
- 130. Fit bolts securing converter to drive plate and tighten to **45 Nm, 33 lbf ft.**



NOTE: Rotate crankshaft during the above procedure.

- 131. Fit bell housing access plate and secure with bolts tightened to **9 Nm, 7 lbf ft.**
- 132. Clean bell housing cover plate and mating face.
- 133. Fit plate and secure with bolts tightened to **9 Nm, 7 lbf ft.**
- 134. Clean rear propeller shaft to brake drum mating faces.
- 135. Release rear propeller shaft, align flange markings and connect to studs.
- 136. Fit nuts securing rear propeller shaft to brake drum and tighten to **47 Nm, 35 lbf ft.**



NOTE: Rotate propeller shaft to gain access to all fixings.

- 137. Clean front propeller shaft to transfer box mating faces.
- 138. Release front propeller shaft, align flange markings and connect to studs.
- 139. Fit nuts securing front propeller shaft to transfer box and tighten to **47 Nm, 35 lbf ft.**



NOTE: Rotate propeller shaft to gain access to all fixings.

- 140. With assistance and using a body jack between chassis longitudinals, jack chassis sufficiently to enable fitment of crossmember.

- 141. Fit crossmember and align fixings.
- 142. Remove body jack.
- 143. Fit nuts and bolts securing chassis crossmember, but do not tighten.
- 144. Fit LH and RH catalyst heat shields to chassis, fit bolts but do not tighten.
- 145. Align LH and RH catalyst heat shields to chassis crossmember fixings and tighten all fixings.
- 146. Clean intermediate to tail pipe flange.
- 147. Fit intermediate pipe to mounting rubber, connect to tail pipe and secure with nuts.
- 148. Fit exhaust front pipe. **See EMISSION CONTROL, Repair, front pipe/catalytic converter; Refit**
- 149. Lower vehicle.
- 150. Fit bolts securing bell housing to engine and tighten to **46 Nm**.



NOTE: Align harness brackets to 2 uppermost bell housing retaining bolts.

- 151. Align breather pipe 'P' clips to rear of RH cylinder head and secure with bolt.
- 152. Secure kick-down outer cable to clip on rear of LH cylinder head.
- 153. Secure kick-down outer cable to abutment bracket.
- 154. Secure kick-down outer cable lock nut.
- 155. Align kick-down cable to linkage and secure clevis pin.
- 156. Adjust kick-down cable. **See Adjustment, kickdown cable adjustment**
- 157. Fit upper fan cowl and secure with clips.
- 158. Align fan cowl to upper retaining brackets and secure with screws.
- 159. Align hand brake cable to lever, fit clevis pin and secure with split pin.
- 160. Position hand brake gaiter and secure with trim studs.
- 161. Secure gearbox and transfer box breather pipes to harness with cable ties.
- 162. Connect inhibitor/reverse light switch multiplug.
- 163. Fit hi-low selector housing cover to tunnel.
- 164. Fit carpet to transmission tunnel.
- 165. Fit centre console. **See CHASSIS AND BODY, Repair, centre console**
- 166. Refill transfer gearbox oil. **See SECTION 10, Maintenance, under vehicle maintenance**
- 167. Refill gearbox oil. **See SECTION 10, Maintenance, under vehicle maintenance**
- 168. Reconnect battery negative lead.
- 169. Select Hi range gear and park.
- 170. Remove vehicle from ramp.



TORQUE VALUES

	Nm	lbf ft
Coupling shaft to mainshaft	42*	30*
Filler tube to sump	68	50
Gear change lever to gearbox	25	18
Cooler pipe adaptor to gearbox	42	30
Securing screws - clutch F	10	7
Securing screw - parking pawl	10	7
Securing screws - pump	10	7
Intermediate plate plugs (M20)	50	35
Intermediate plate plugs (M14)	40	30
Bell housing mounting bolts	46	34
Governor mounting screws	10	7
Extension housing bolts	23	17
Control unit mounting bolts	8	6
Draib plug - fluid pan	10	7
Mounting screws for sump	8	6
Drive plate to converter	39*	29*
Gearbox to engine	42	31
Strut (threaded end)	42	31
Bottom cover to converter housing	9	7
Cover - converter housing	9	7
Drive plates to crankshaft adaptor	40*	30*
Adaptor to crankshaft	84	62

NOTE: * These bolts MUST have threads coated with Loctite 270 prior to assembly.



Torque values below are for all screws and bolts used except for those that are specified otherwise.

METRIC	Nm	lbf ft
M5	6	5
M6	9	7
M8	25	18
M10	45	33
M12	90	65
M14	105	75
M16	180	130

UNC / UNF	Nm	lbf ft
1/4	9	7
5/16	24	18
3/8	39	28
7/16	78	58
1/2	90	65
5/8	136	100

ZF GEARBOX DATA

Axial end float.....	0.2 - 0.4 mm.	0.008 - 0.016 in
From torque converter boss to torque converter housing face	50 mm	1.968 in
Freewheel cage assembly to ring gear; minimum clearance	0.1 mm	0.004 in
Output shaft dimension above cylinder F assembly	10.00 mm	0.394 in
A cylinder maximum protrusion above gearbox front face	8.5 mm	0.335 in



PROPELLER SHAFT ALIGNMENT

Description

The front and rear propeller shafts have non-constant velocity 'Hooks' type universal joints, with needle roller bearings. The bearing cups are pre-packed with lubricant on assembly and a grease nipple is fitted for servicing as specified, in maintenance section.

Both shafts have Rilsan coated sliding splines to accommodate the variation in distance between the axles and transmission. The splines are pre-packed with lubricant and sealed.

The front shaft is a solid bar, which is shorter than the rear, with the joints 'Phased' at each end, A and B mis-aligned. The phasing is necessary on the front shaft only to allow for greater variation in angular changes.

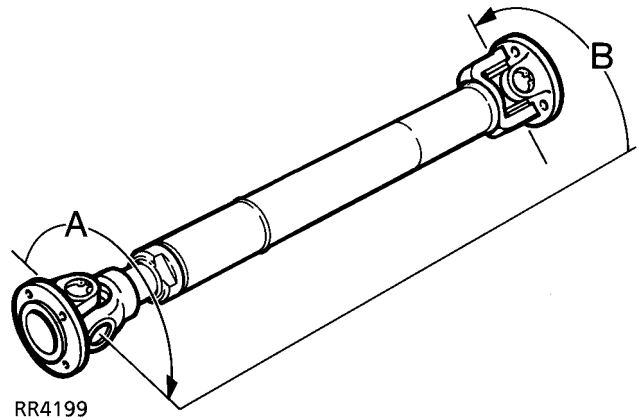

RR4199

The rear shaft is a tube fitted with a conventional joint at gearbox end and the sliding joint sealed with a rubber gaiter.

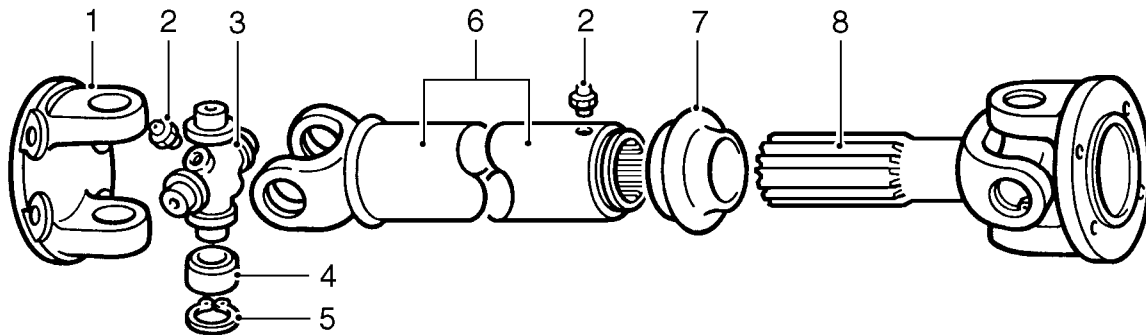

J6284

Propeller shaft

- 1. Flanged yoke
- 2. Grease nipple
- 3. Journal spider
- 4. Needle roller bearing
- 5. Circlip
- 6. Splined shaft
- 7. Rubber gaiter (dust cap)
- 8. Splined shaft



VIBRATION HARSHNESS

1. Check that the propeller shaft universal joints and sliding splines are not siezed or worn and that the shafts are correctly aligned.



NOTE: In the event that both shafts are satisfactory, but the vibration/harshness is still present, the transfer box operation and balance of the road wheels should be checked.

For transfer gearbox operation. **See TRANSFER GEARBOX, Description and operation, LT230Q Transfer Gearbox**

For balance of road wheels. **See WHEELS AND TYRES, Repair, Wheel Balancing**



PROPELLER SHAFTS

Service repair no - 47.15.02 - Front

Service repair no - 47.15.03 - Rear

Remove

1. Place vehicle over pit or on a ramp [hoist].
2. Remove nuts from each end of propeller shaft. Remove shaft.
3. Scribe alignment marks on flanges at both ends of propeller shaft to ensure correct refitting.

Overhaul

Service repair no - 47.15.11 - Front

Service repair no - 47.15.12 - Rear

4. Thoroughly examine universal joint for signs of damage or wear. Replace if necessary.

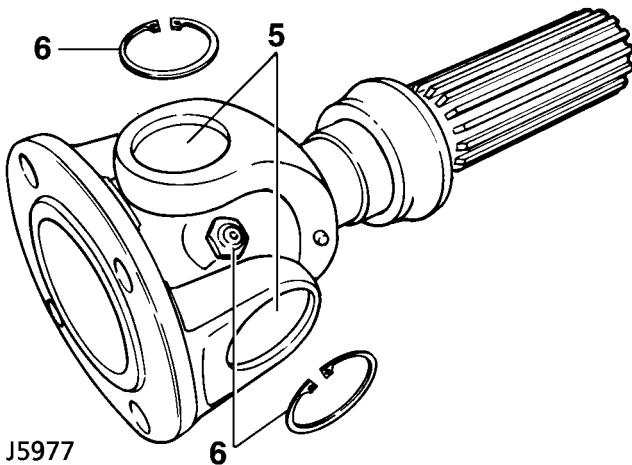

J5977

5. Clean universal joint bearing cups and circlips.



CAUTION: To ensure correct assembly and reduce possibility of imbalance.

Before removing propeller shaft joint. Mark position of spider pin lubricator relative to journal yoke ears.

6. Remove circlips, and grease nipple.
7. Tap yokes to eject bearing cups.
8. Remove bearing cups and spider.
9. Repeat instructions 4 to 7 for opposite end of propeller shaft if necessary.
10. Clean yokes and bearing cup locations.

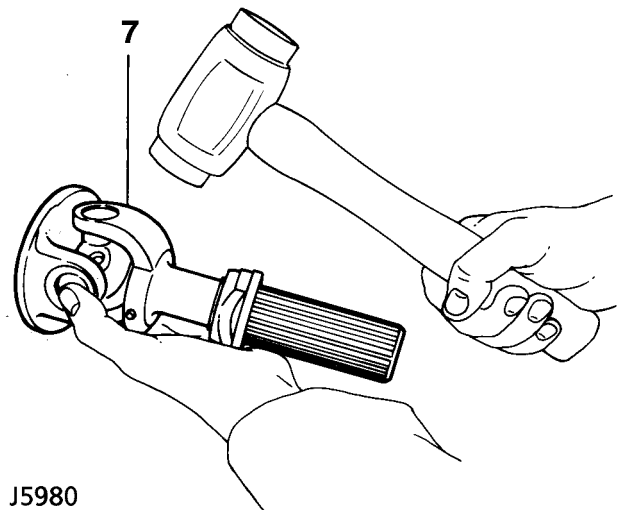

J5980

Assemble

11. Remove bearing cups from new spider.
12. Check all needle rollers are present and positioned in bearing cups.
13. Ensure bearing cups are one-third full of lubricant. **See LUBRICANTS, FLUIDS AND CAPACITIES, Information, Recommended Lubricants and Fluids**
14. Enter new spider with seals into yokes of sliding member flange.
15. Partially insert one bearing cup into flange yoke and enter spider trunnion into bearing cup.
16. Insert opposite bearing cup into flange yoke.
17. Press both cups into place.

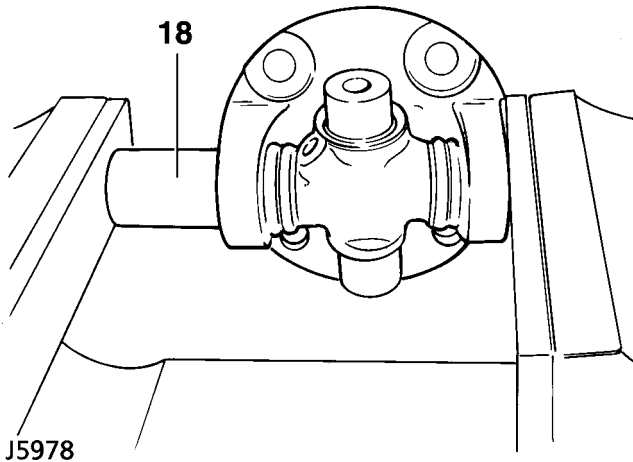

18. Press each cup into its respective yoke up to lower land of circlip grooves. Damage may be caused to cups and seals if cups pass this point.
19. Fit circlips and check no end float exists.

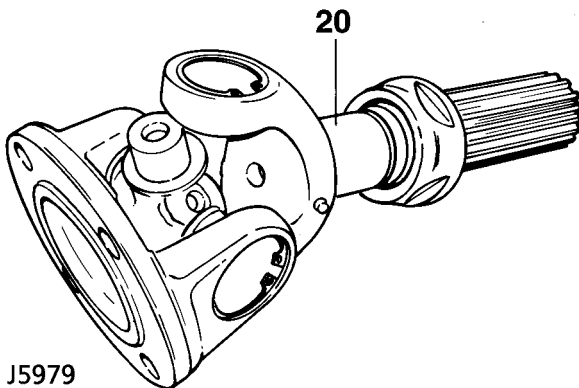

20. Engage spider in yokes of sliding member. Fit bearing cups and circlips as described in instructions 14 to 19.
21. Fit grease nipples to spider and sliding member.
22. Apply instructions 14 to 19 to opposite end of propeller shaft.
23. Fit grease nipple and lubricate.

Refit

24. Fit propeller shafts to vehicle and tighten nuts to **47Nm, 35 lbf ft**
Refit propeller shaft so sliding joint end of shaft is fitted to transfer gearbox.



TORQUE VALUES

	Nm	lbf ft
Propeller shaft flange nuts	47	35



DESCRIPTION

The welded steel rear axle casing houses a separate spiral bevel type differential unit, which is off set to the right of the vehicle centre line. The differential unit drives the rear wheels via the axle shafts and fully floating hubs which are mounted on tapered roller bearings.

Lubrication

The differential is lubricated with oil and the hub bearings with grease. The hub bearings are fitted with inner and outer seals. The outer seals prevent the differential oil mixing with the hub grease and the inner seals prevent dirt ingress into the hub.

Ventilation

Ventilation of the hub bearings is through the outer oil seals and the differential ventilation pipe, which terminates at a high level.

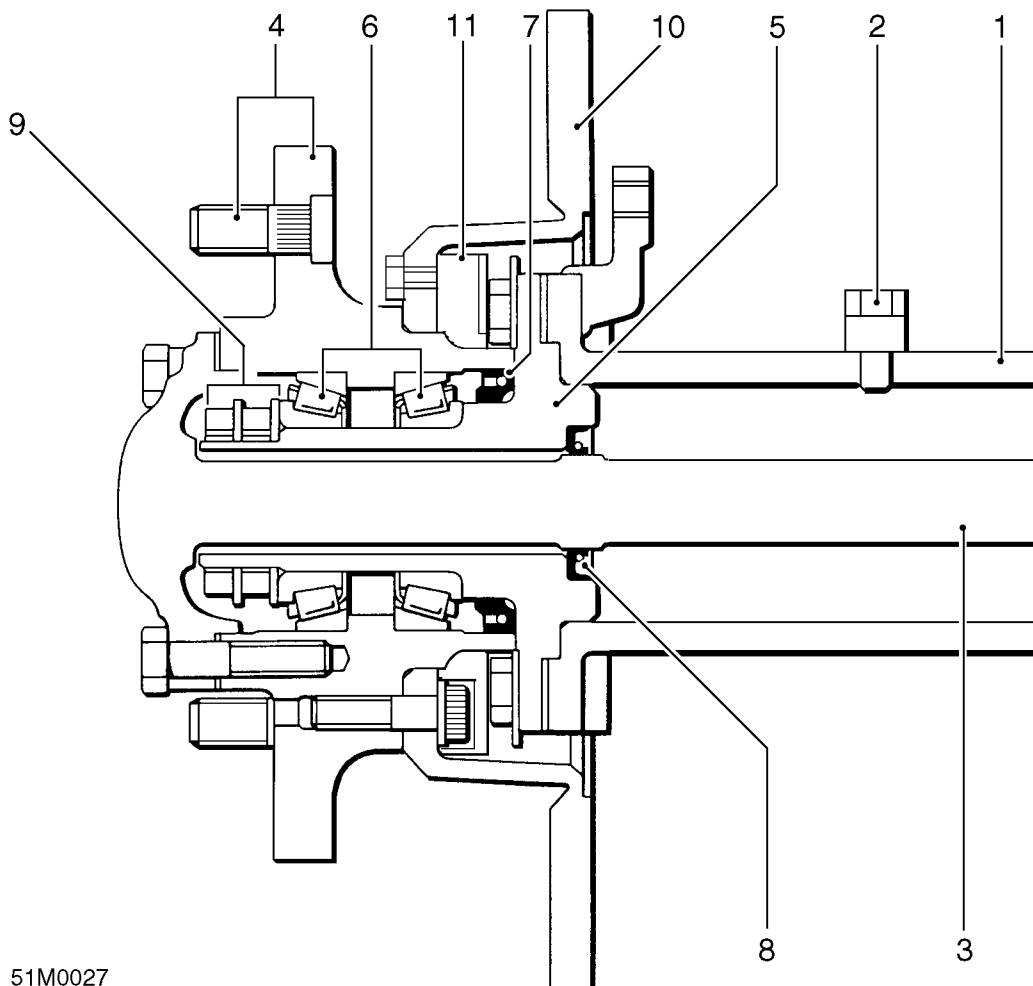

51M0027

Rear axle hub

- | | |
|----------------------------|---|
| 1. Axle casing | 7. Inner hub seal |
| 2. Ventilation pipe | 8. Outer hub/axle shaft seal |
| 3. Axle shaft | 9. Hub lock plate, thrust washer and nuts (2) |
| 4. Wheel studs and hub | 10. Brake disc |
| 5. Wheel bearing stub axle | 11. Sensing ring - road speed |
| 6. Wheel bearings (2) | |



FAULT DIAGNOSIS

Complaint - Oil leaks

An external leak of lubricant from the hub seals can be caused by a faulty internal seal. For example, if the seals which separate the differential from the hubs are faulty and the vehicle is operating or parked on an embankment, oil from the differential may flood one hub resulting in a lack of lubrication in the differential.

When a seal is found to be leaking check the axle ventilation system, as a blockage can cause internal pressure to force oil past the seals.

See '**Description and Operation**' for an illustration of oil seal locations.

When investigating hub seal leaks, check the grease for dilution with oil. Also check the differential oil level, for signs of metal particles in the oil and the condition of internal seals.

If the vehicle is driven in deep water with defective oil seals, water may contaminate the lubricants and raise the differential oil level, giving a false impression that the housing has been overfilled. **Do not assume that a high oil level in the differential is due to over filling or, that a low level is because of an external leak.**



REAR AXLE

Service repair no - 51.25.01

Remove



WARNING: Remove and refit of axle requires a further 2 persons to steady the axle when lowering or repositioning.

1. Drain brake system.
2. Support rear of chassis.
3. Remove rear road wheels.
4. Support axle weight with hydraulic jack.
5. Disconnect shock absorbers.
6. Disconnect flexible brake hose at RH chassis crossmember and ventilation pipe at banjo connection on axle casing.
7. Disconnect lower links at axle.

8. Mark differential and propeller shaft flanges with alignment marks for assembly.
9. Remove 4 nuts and bolts, lower propeller shaft and tie to one side.
10. Disconnect pivot bracket ball joint at axle bracket. Disconnect wheel speed sensor lead plugs at LH side of chassis. Release sensor lead retaining clips from chassis and 'A' frame.
11. Release bolts and remove coil spring retaining plates.
12. Lower axle and remove road springs.
13. Remove anti-roll bar links at axle **See REAR SUSPENSION, Repair, anti-roll [sway] bar ball joint links**
14. Remove axle assembly.

Do not carry out further dismantling if component is removed for access only.

15. Transfer components to new axle.

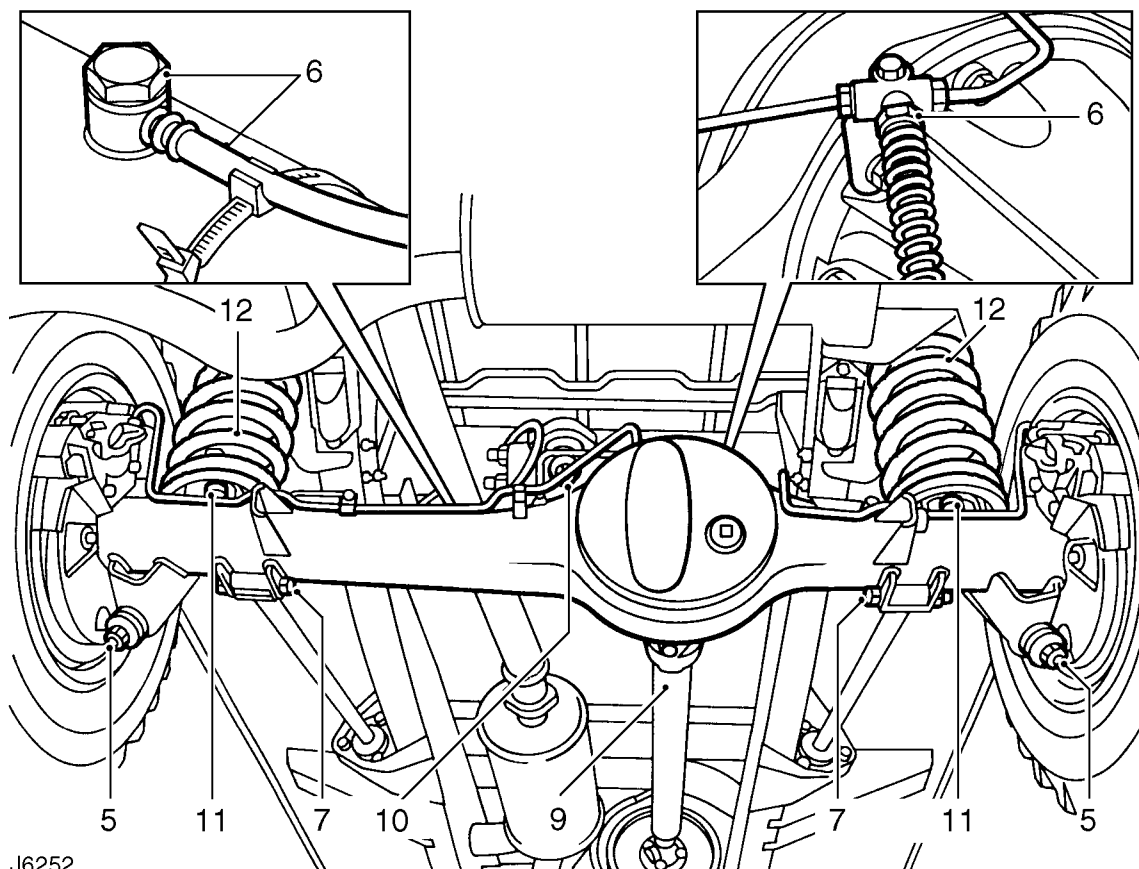

J6252

Refit

16. Position axle and fit lower links. Tighten fixings to **175 Nm, 130 lbf/ft.**
17. If applicable, fit anti-roll bar links to axle **See REAR SUSPENSION, Repair, anti-roll bar joint links .**
18. Raise axle and locate road springs.
19. Fit coil spring retaining plates and secure with fixing bolts.
20. Secure pivot bracket ball joint to axle bracket. Tighten fixing to **175 Nm, 130 lbf/ft.**
21. Reconnect road speed sensor lead plugs and secure leads to chassis and 'A' frame.
22. Align propeller shaft to differential drive flange and tighten fixings to **48 Nm, 35 lbf/ft.**
23. Reconnect flexible brake hose and axle ventilation pipe.
24. Refit shock absorbers.
25. Fit road wheels.
26. Remove rear chassis support.
27. Bleed brake system. **See BRAKES, Repair, brake system bleed**

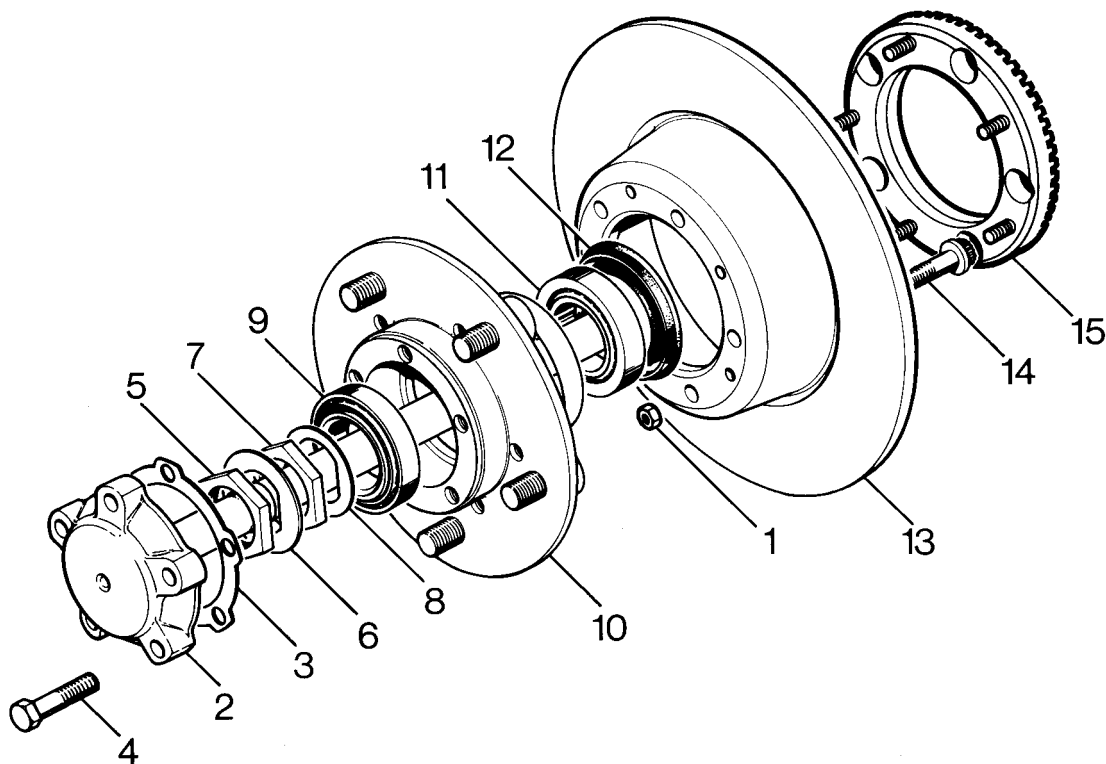

J5352M

Rear hub components

- | | |
|--|---|
| <ul style="list-style-type: none"> 1. Nut - sensor ring 2. Axle shaft. 3. Axle shaft joint washer. 4. Axle shaft retaining bolt - 5 off. 5. Lock nut. 6. Lock washer. 7. Hub adjusting nut. 8. Spacing washer. | <ul style="list-style-type: none"> 9. Outer bearing. 10. Hub. 11. Inner bearing. 12. Grease seal. 13. Brake disc. 14. Disc retaining bolt - 5 off. 15. Sensor ring - engine management |
|--|---|

REAR HUB ASSEMBLY

Service repair no - 64.15.01

Remove

- 1. Raise rear of vehicle and support rear axle onto axle stands. Remove appropriate road wheel.
- 2. Release brake hose clips and remove brake caliper bolts. Secure caliper to one side.

- 3. Remove 5 bolts and withdraw axle shaft.
- 4. Remove and discard joint washer.
- 5. Bend back lock washer tabs.
- 6. Remove locknut and lock washer. Discard lock washer.
- 7. Remove hub adjusting nut.
- 8. Remove spacing washer.
- 9. Remove hub and brake disc assembly complete with bearings.



WARNING: Take care not to kink brake hose.

Refit

10. Clean stub axle.
11. Fit hub assembly to stub axle.

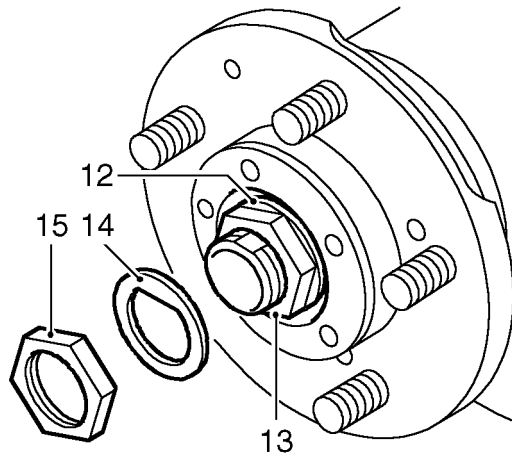

J6255

12. Fit spacing washer.
13. Fit hub adjusting nut. Tighten to **50 Nm, 37 lbf/ft** ensure hub is free to rotate with no bearing play. Back off adjusting nut 90° and tighten to **10 Nm, 7 lbf/ft**.
14. Fit a NEW lock washer.
15. Fit locknut. Tighten to **61 Nm, 45 lbf/ft**.
16. Tab over lock washer to secure adjusting nut and locknut.
17. Using a NEW joint washer, fit axle shaft to hub. Tighten bolts to **65 Nm, 48 lbf/ft**.
18. Fit brake caliper. Tighten bolts to **82 Nm, 60 lbf/ft**. Secure brake pipes to axle casing.
19. Fit road wheel, remove axle stands and tighten road wheel nuts to **130 Nm, 95 lbf/ft**.
20. Operate footbrake to locate brake pads before driving vehicle.

DIFFERENTIAL ASSEMBLY

Service repair no - 51.15.01

Remove

1. Raise and support rear axle on axle stands. Position drain tray and drain axle oil. Refit drain plug.
2. Mark differential and propeller shaft flanges to facilitate reassembly.

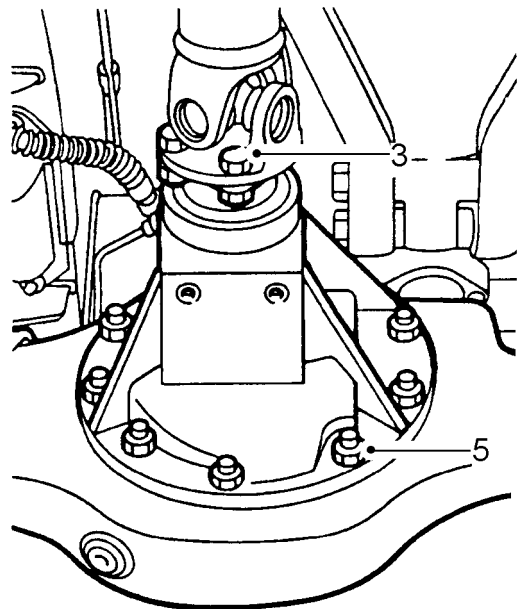

51M0028

3. Remove 4 bolts and disconnect propeller shaft from differential. Tie aside.
4. Remove hub drive member fixings and withdraw axle half shafts sufficiently to disengage from differential unit. **See rear hub assembly**
5. Remove 10 locknuts securing differential to axle case.
6. Withdraw differential unit.



NOTE: The differential unit can only be serviced as a complete assembly with matching drive pinion.

**Refit**

7. Ensure mating faces are clean and apply a bead of RTV sealant to axle case flange.
8. Support differential unit and position on axle casing.
9. Secure with lock nuts and tighten to **40 Nm, 30lbf/ft.**
10. Align marks on flanges and secure propeller shaft to differential. Tighten bolts to **48 Nm, 35 lbf/ft.**
11. Refit half shafts. **See Rear hub assembly**
12. Refill axle oil with approved lubricant. **See LUBRICANTS, FLUIDS AND CAPACITIES, Information, recommended lubricants and fluids**



REAR HUB ASSEMBLY

Service repair no - 64.15.14.

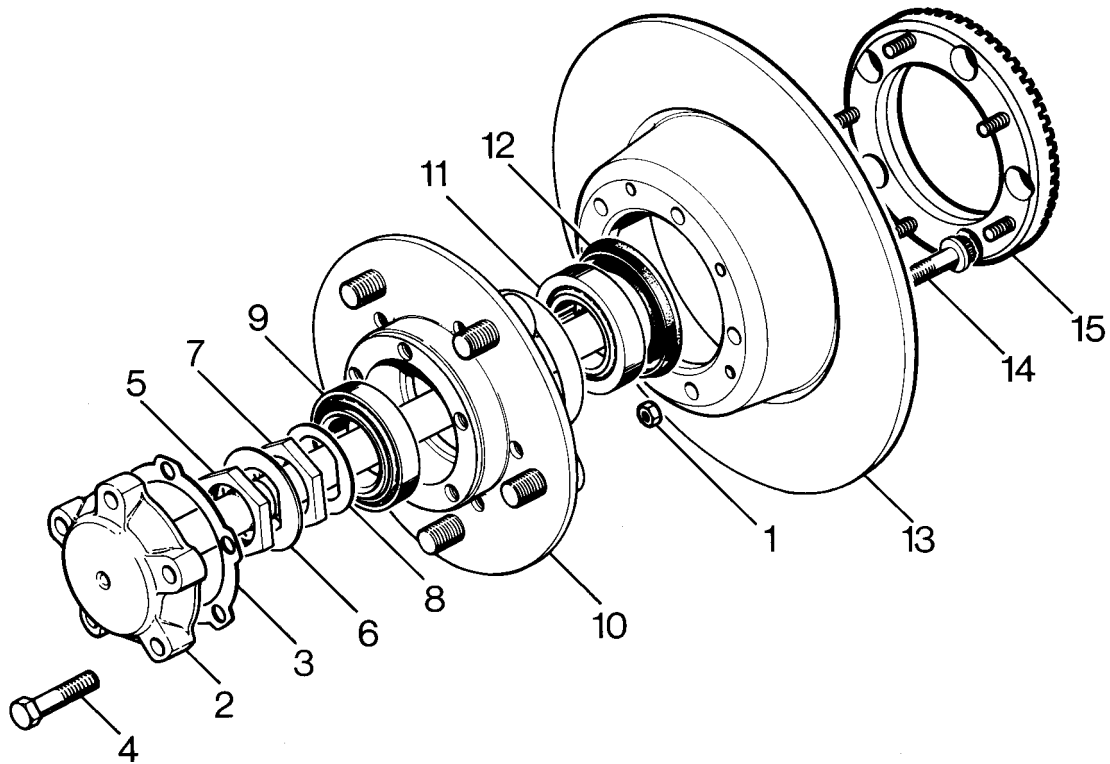

J5352M

REAR HUB COMPONENTS

- | | |
|---------------------------------------|-------------------------------------|
| 1. Nut - sensor ring | 9. Outer bearing. |
| 2. Axle shaft. | 10. Hub. |
| 3. Axle shaft joint washer. | 11. Inner bearing. |
| 4. Axle shaft retaining bolt - 5 off. | 12. Grease seal. |
| 5. Lock nut. | 13. Brake disc. |
| 6. Lock washer. | 14. Disc retaining bolt - 5 off. |
| 7. Hub adjusting nut. | 15. Sensor ring - engine management |
| 8. Spacing washer. | |

Remove

1. Remove rear hub. *See Repair, rear hub assembly*
2. Remove outer bearing.
3. Mark, for reassembly, position of hub to brake disc.
4. Remove 5 bolts and separate hub from brake disc.



WARNING: A maximum of two road wheel retaining studs can be renewed. Should more studs be unserviceable fit new hub with studs.

with studs.

5. Remove grease seal and inner bearing from hub.
6. Remove inner and outer bearing tracks.

Refit

7. Clean hub and fit inner and outer bearing tracks.

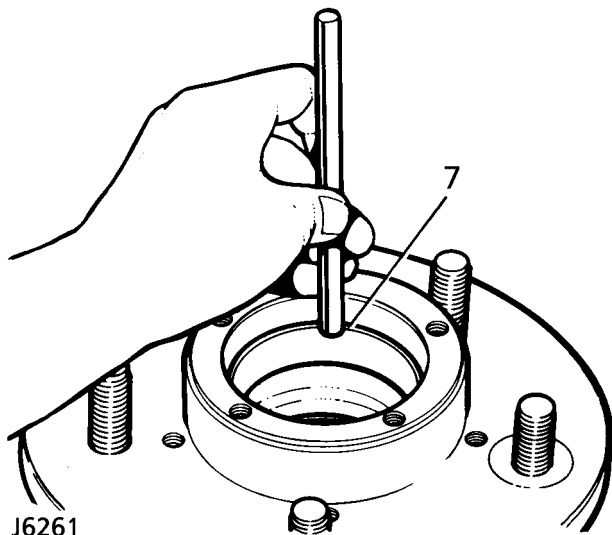

J6261

8. Pack hub inner bearing with grease and fit to hub.
9. With lip side leading fit a new seal flush with rear face of hub. Using service tool **LRT-54-003** seal replacer and drift. Apply grease between seal lips.

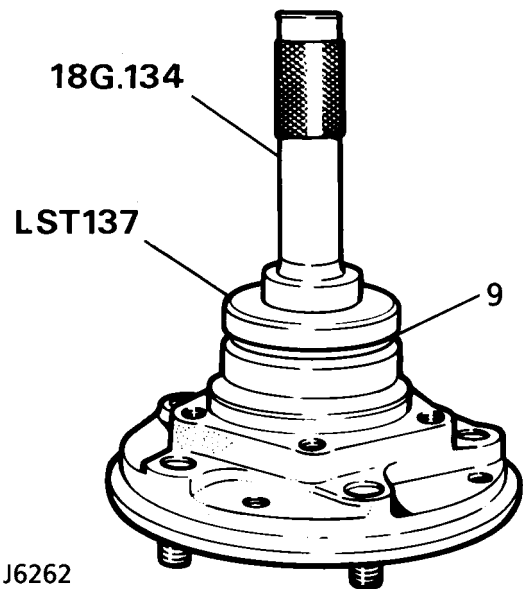

J6262

10. Assemble brake disc to the hub, line up reassembly marks. Applying Loctite 270, fit and tighten retaining bolts to **73 Nm, 55 lbf/ft.**
11. Pack hub outer bearing with grease and fit to hub.
12. Fit rear hub assembly. *See Repair, Rear Hub Assembly*



REAR STUB AXLE

Service repair no - 64.15.22.

STUB AXLE COMPONENTS

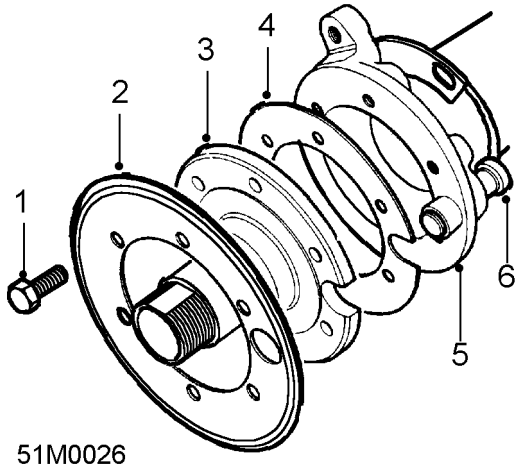

51M0026

1. Stub axle to axle casing bolt
2. Mudshield
3. Stub axle
4. Stub axle joint washer
5. Axle casing
6. Wheel speed sensor

Overhaul

1. Remove hub assembly. **See Repair, Rear Hub Assembly**
2. Remove 6 bolts securing stub axle to axle casing.
3. Remove mudshield.
4. Remove stub axle and joint washer.

Renew rear stub axle oil seal

5. Remove and discard oil seal. Lubricate seal and lip with EP90 oil. Using special tool **LRT-51-004**(LST.138) fit new oil seal lipside trailing so that seal is flush with rear face of stub axle.

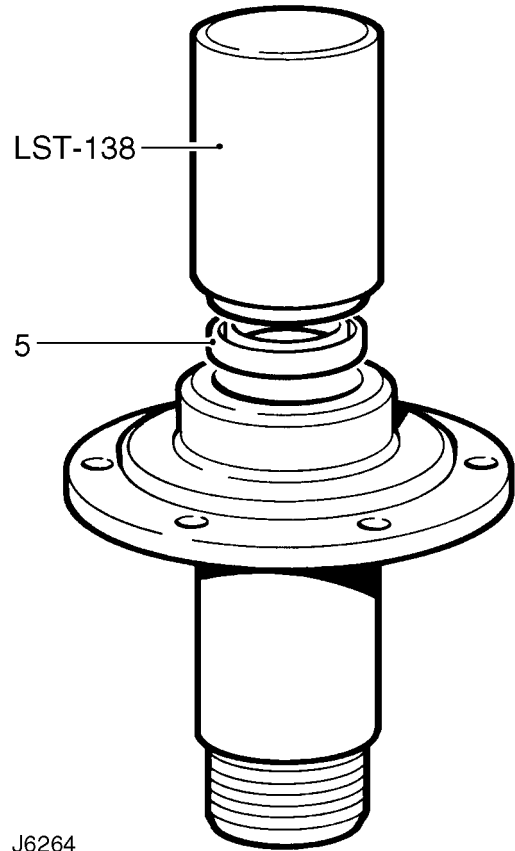

J6264

Refit

6. Fit new joint washer, stub axle and mudshield bolts. Tighten bolts to **65 Nm, 50 lbf/ft**.
7. Refit hub assembly **See Repair, Rear Hub Assembly**



TORQUE VALUES

REAR AXLE	Nm	lbf ft
Drive shaft flange bolts	48	35
Lower link to axle	176	130
Pivot bracket ball joint to axle	176	130
Stub axle bolts	65	50



DESCRIPTION

The welded steel front axle casing houses a separate spiral bevel type differential unit, which is off set to the right of the vehicle centre line. The differential unit drives the front wheels via the axle shafts and constant velocity joints which are totally enclosed in the spherical and swivel housings.

The front wheels are pivoted on a taper roller bearing at the bottom and a 'Rialco' bush at the top of the swivel housing. The top swivel also houses the wheel sensor used by engine management. The wheel hubs are supported by 2 taper bearings and driven by drive flanges which are splined to the one piece stub shaft/constant velocity joint.

Lubrication

The differential, swivel pin housing and wheel hubs are individually lubricated and separated by oil seals to prevent oil transfer across the axle when the vehicle is traversing steep inclines. The wheel bearings are lubricated with grease and the differential with oil. The swivel housings are lubricated with grease unless the housing is fitted with filler and level plugs then oil is used.

Ventilation

Ventilation of the differential is through a plastic pipe which terminates at a high level in the vehicle. The swivel housings ventilate through the axle shaft oil seals into the differential and the hub bearings vent via the oil seals into the swivel housing.

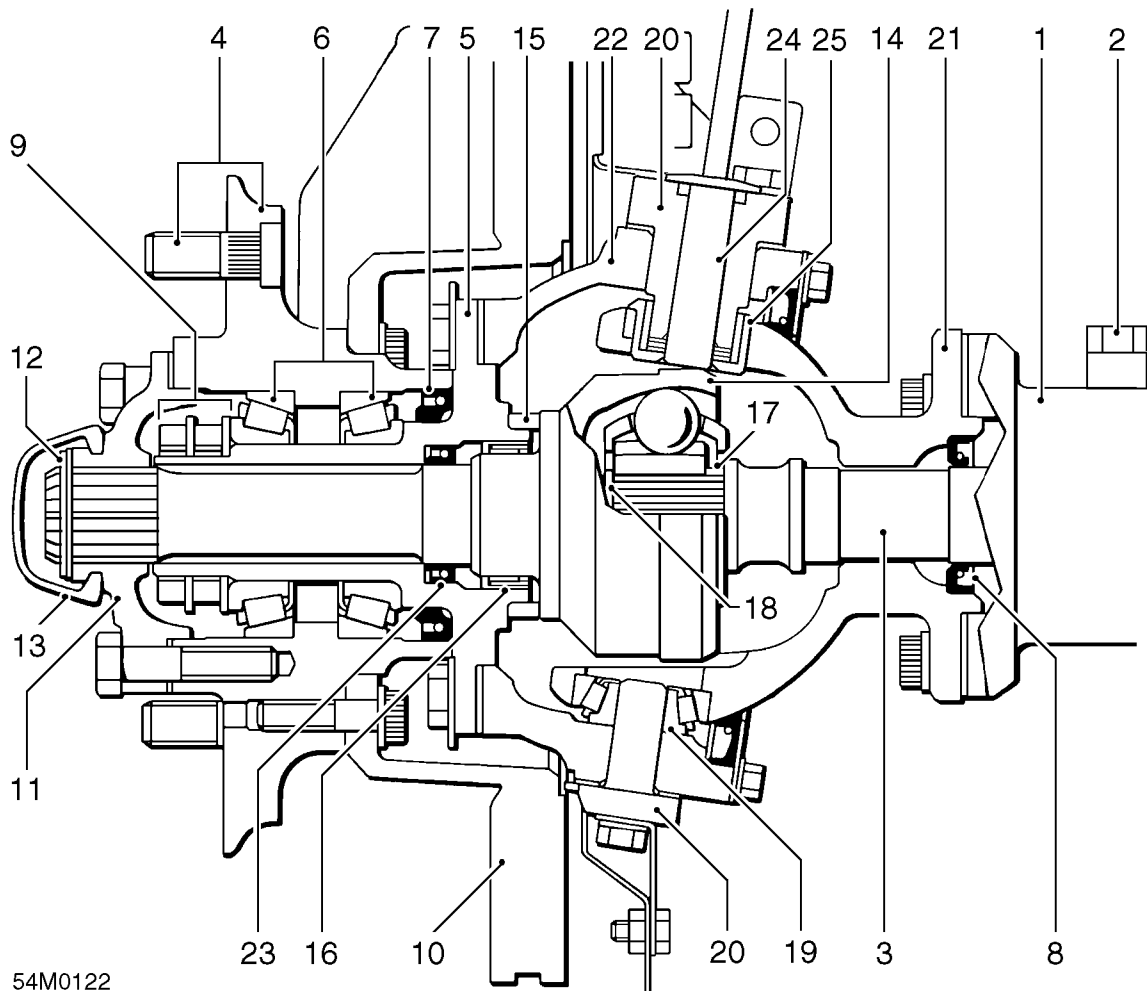

Front axle

- | | |
|---|--|
| 1. Axle casing | 14. Constant velocity joint/shaft |
| 2. Ventilation pipe | 15. Thrust collar for CV joint |
| 3. Axle shaft | 16. Roller bearing |
| 4. Wheel studs and hub | 17. Spacer |
| 5. Stub axle | 18. Circlip |
| 6. Wheel bearings - 2 | 19. Top and bottom swivel taper bearings |
| 7. Inner and outer hub seals | 20. Top and bottom swivel pins |
| 8. Axle shaft seal | 21. Spherical housing, seal and retainer |
| 9. Hub lock plate, thrust washer and nuts - 2 | 22. Swivel housing |
| 10. Brake disc | 23. Constant velocity shaft seal |
| 11. Drive flange | 24. Speed sensor - engine management |
| 12. Shim washer and circlip | 25. 'Rialco' bush - sensor |
| 13. Dust cap | |



FAULT DIAGNOSIS

Complaint - Oil leaks

An external leak of lubrication can be caused by a faulty internal seal. For example, if the seals which separate the differential from the swivel housings are faulty and the vehicle is operating or parked on an embankment, oil may leak across the axle leaving one swivel with a high level and the opposite swivel and differential lacking lubrication.

See '**Description and Operation**' for illustration showing oil seal locations.

When investigating leaks or checking oil levels, it is essential that all the lubrication is drained from any housing with a high level and that the other levels are checked.

Swivel housing oil (where used) should be checked for signs of grease leaking from the hub bearings and oil contamination of the hub grease.

Check that the axle ventilation system is clear, as a blockage can cause internal pressure to force oil past the seals.

If the vehicle is driven in deep water with defective oil seals, water may contaminate the lubricants and when checked, give a false impression that the housing has been overfilled with oil.

Do not assume that a high oil level is due to over filling or, that a low level is because of an external leak.



FRONT AXLE ASSEMBLY

Service repair no - 54.15.01

Remove



WARNING: Remove and refit of axle requires a further 2 persons to steady axle when lowering or repositioning.

1. Raise and support chassis front.
2. Remove front road wheels.
3. Support axle weight with hydraulic jack.

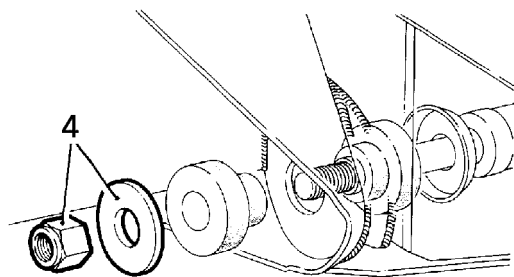

RR983

4. Remove both radius arm to chassis frame lock nuts.
5. Disconnect steering damper from track rod. Using an extractor remove track rod links from swivel pin arms.
6. Remove 4 nuts and bolts securing radius arms to axle bracket.
7. Disconnect radius arms from axle.
8. Remove bolts securing brake hose brackets. Refit bolts to prevent oil leakage.
9. Remove both wheel sensor lead plugs and release lead retaining clips.
10. Remove bolts from brake calipers and tie calipers to one side. **DO NOT strain hoses.**
11. Remove nuts and washers securing shock absorbers to axle.
12. Disconnect drag link from swivel pin housing arm.
13. Remove 2 nuts and bolts securing panhard rod to axle bracket. Lift rod clear of axle.
14. Mark drive shaft flanges for reassembly. Remove 4 nuts and bolts, tie propeller shaft to one side.
15. Release axle ventilation pipe banjo and lower axle assembly. Remove road springs.

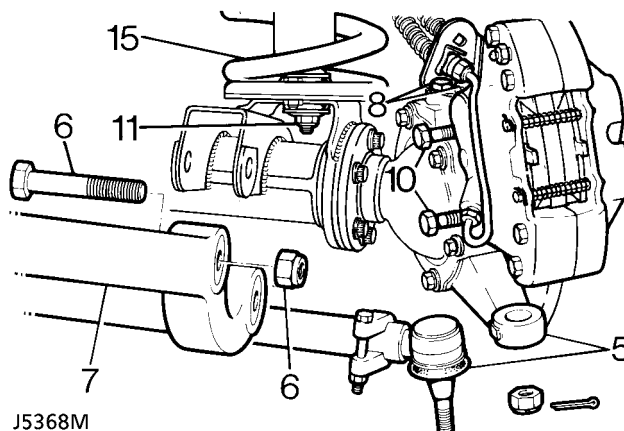

J5368M

16. Disconnect anti-roll bar link *See FRONT SUSPENSION, Repair, Anti-roll bar ball joint links*.
17. Remove axle assembly.

Do not carry out further dismantling if component is removed for access only.

18. Transfer components to new axle.

Refit

19. Position axle under vehicle, supporting left side of axle.
20. Fit road springs, axle ventilation pipe banjo and raise axle assembly.
21. Align reference marks and fit propeller shaft. Tighten bolts to **47 Nm, 35 lbf/ft.**
22. Fit panhard rod to axle bracket. Tighten bolts to **88 Nm, 65 lbf/ft.**
23. Fit drag link to swivel pin arm. Tighten fixings to **40 Nm, 30 lbf/ft.**
24. Fit shock absorbers to axle.
25. Fit brake calipers. Tighten bolts to **82 Nm, 60 lbf/ft.**
26. Tighten upper swivel pin bolts to **65 Nm, 50 lbf/ft.**
27. Reconnect both wheel sensor lead plugs and fit lead retaining clips.
28. Fit radius arms to axle brackets. Tighten bolts to **197 Nm, 145 lbf/ft.**
29. Fit steering damper to track rod.
30. Fit radius arms to chassis side member. Tighten fixings to **197 Nm, 145 lbf/ft.**
31. Tighten track rod end to **40 Nm, 30 lbf ft** align to hole and fit NEW split [cotter] pin.
32. Fit road wheels, tighten to **130 Nm, 95 lbf ft.**
33. Remove chassis supports.

FRONT HUB ASSEMBLY

Service repair no - 60.25.01.

Remove

1. Loosen road wheel nuts, raise front of vehicle and lower onto axle stands. Remove road wheel.
2. Release brake hose clips and remove brake caliper and brake disc shield bolts. Secure caliper to one side.
3. Lever off dust cap.
4. Remove circlip and driveshaft shim from driveshaft.
5. Remove 5 bolts and withdraw drive member and joint washer. Discard joint washer.
6. Bend back lock washer tabs.
7. Remove locknut and lock washer.
8. Remove hub adjusting nut.
9. Remove spacing washer.
10. Remove hub and brake disc assembly complete with bearings.

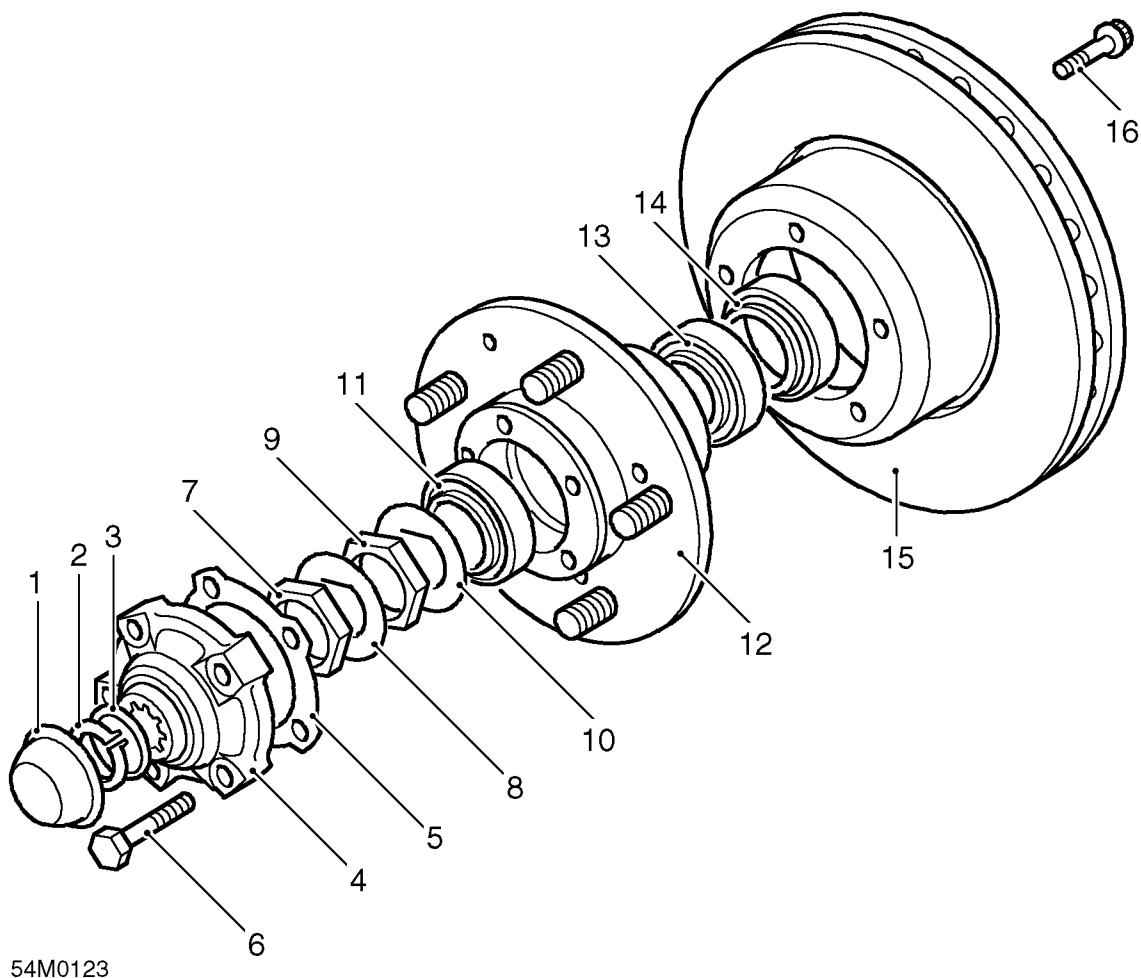
**HUB COMPONENTS**

- | | |
|--|---|
| <ol style="list-style-type: none"> 1. Dust cap. 2. Drive shaft circlip. 3. Drive shaft shim. 4. Drive member. 5. Drive member joint washer. 6. Drive member retaining bolt. 7. Lock nut. 8. Lock washer. | <ol style="list-style-type: none"> 9. Hub adjusting nut. 10. Spacing washer. 11. Outer bearing. 12. Hub. 13. Inner bearing. 14. Grease seal. 15. Brake disc. 16. Disc retaining bolt. |
|--|---|



Refit

1. Clean stub axle and drive shaft and fit hub assembly to axle.

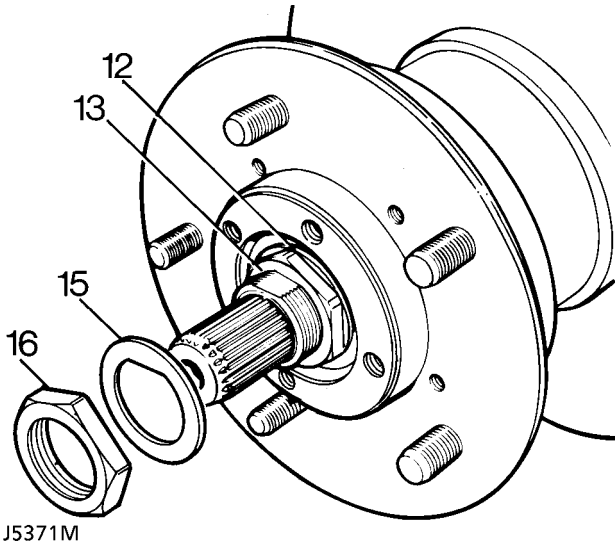

J5371M

2. Fit spacing washer.
3. Fit hub adjusting nut. Tighten to **50 Nm, 37 lbf ft.** Ensure hub is free to rotate with no bearing play.
4. Back off adjusting nut 90° and tighten to **10 Nm, 7 lbf ft.** This will give the required hub end float of 0,010mm, 0.0004 in.
5. Fit a new lock washer.
6. Fit locknut. Tighten to **50 Nm, 37 lbf ft.**
7. Tab over lock washer to secure adjusting nut and locknut.
8. Fit a new joint washer to driving member and fit member to hub. Tighten bolts to **65 Nm, 48 lbf ft.**
9. Fit original drive shaft shim and secure with a circlip.

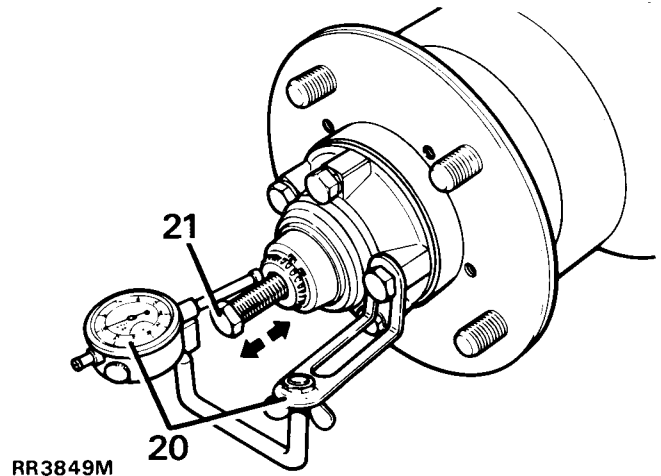

RR3849M

10. To check drive shaft end play, mount a dial gauge using bracket **LRT-99-503** and rest pin in a loaded condition on end of drive shaft.
11. Fit a suitable bolt to threaded end of drive shaft. Move drive shaft in and out noting dial gauge reading. End play should be between 0,08 to 0,25 mm, 0.003 to 0.010 in.
12. If end play requires adjustment, remove circlip, measure shim thickness and fit an appropriate shim to give required end-play.
13. Remove bolt from drive shaft, fit circlip and dust cap.
14. Fit brake disc shield and brake caliper. Tighten fixings to **82 Nm, 60 lbf ft.**
15. Bleed brake system. **See BRAKES, Repair, Brake system bleed**
16. Fit road wheel, remove axle stands and tighten road wheel nuts to **130 Nm, 95 lbf ft.**
17. Operate footbrake to locate brake pads.



FRONT DIFFERENTIAL

Service repair no - 54.10.07.

Overhaul



NOTE: The front axle differential is the same as that fitted to the rear axle and can only be serviced as a complete assembly
See *REAR AXLE AND FINAL DRIVE, Repair, Rear differential* .

FRONT HUB

Service repair no - 60.26.14.

Overhaul

1. Remove hub assembly *See Repair, Front hub assembly*
2. Remove outer bearing.
3. Mark, for reassembly, relationship between hub and brake disc, if original hub is to be refitted.
4. Remove 5 bolts and separate hub from brake disc.
5. Drift out grease seal and inner bearing from hub and discard seal.

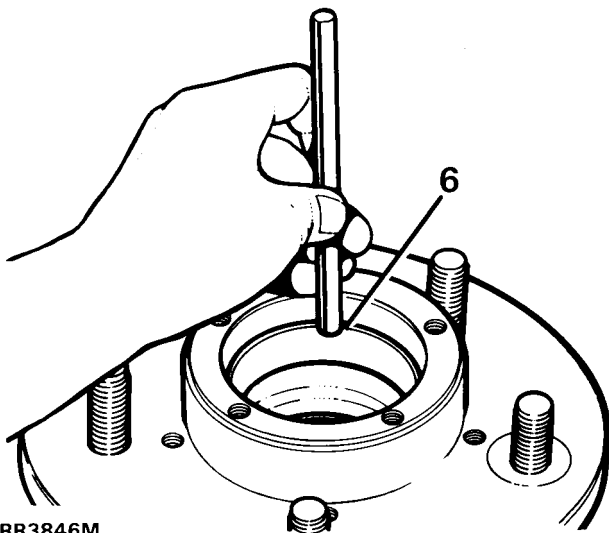

RR3846M

6. Drift out inner and outer bearing tracks.
7. Clean hub and drift in inner and outer bearing tracks.
8. Pack hub inner bearing with recommended grease and fit to hub.

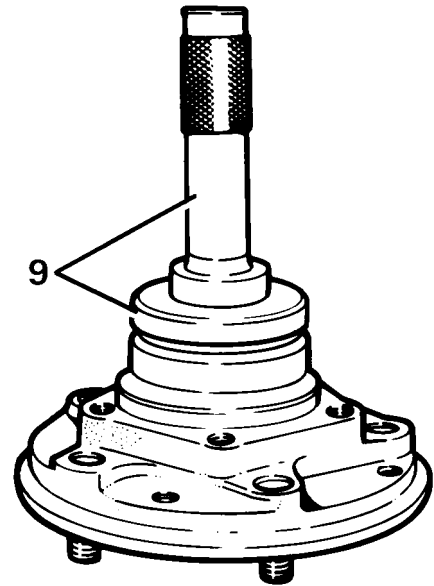

RR3845M

9. With lip side leading fit new seal to hub using special tool **LST 137** seal replacer and drift **18G 134**. Drive in seal flush with rear face of hub. Apply grease between seal lips.
10. Fit brake disc to hub, lining up to marks made during dismantling. Apply Loctite 270, fit retaining bolts. Tighten to **73 Nm, 55 lbf/ft.**
11. Grease and fit outer bearing to hub.
12. Fit hub assembly. *See Repair, Front hub assembly*

FRONT STUB AXLE, CONSTANT VELOCITY JOINT AND SWIVEL PIN HOUSING

Service repair no - 60.15.43.

Remove stub axle, axle shaft and constant velocity joint.

1. Remove front hub assembly. *See Repair, Front Hub Assembly*
2. Drain swivel pin housing and refit plug.

 **NOTE:** On later vehicles the swivel pin housing is filled with grease for life service. The level and drain plugs have been deleted.

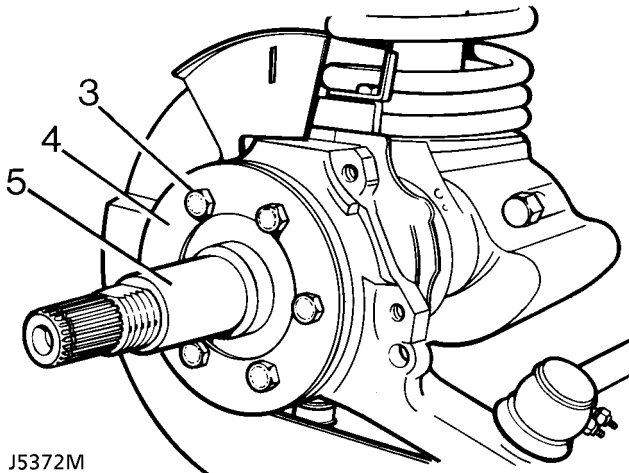

3. Remove 6 bolts retaining stub axle to swivel housing.
4. Remove mud shield.
5. Remove stub axle and joint washer.

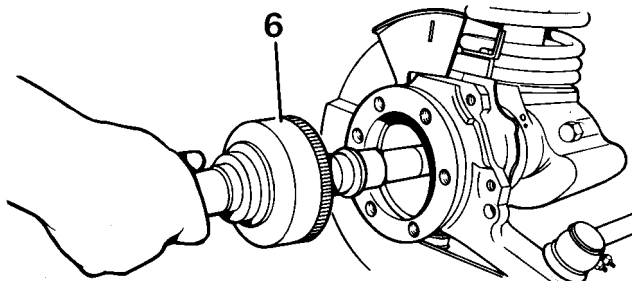

6. Pull out axle shaft and constant velocity joint from axle casing.

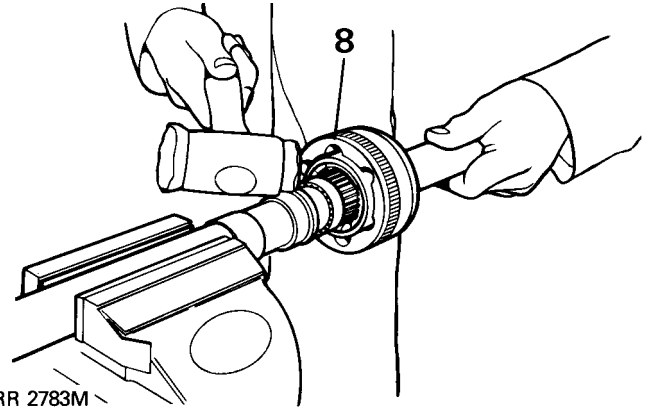

Remove constant velocity joint from axle shaft

7. Hold axle shaft firmly in a soft jawed vice.
8. Using a soft mallet drive constant velocity joint from shaft.
9. Remove circlip and collar from axle shaft.

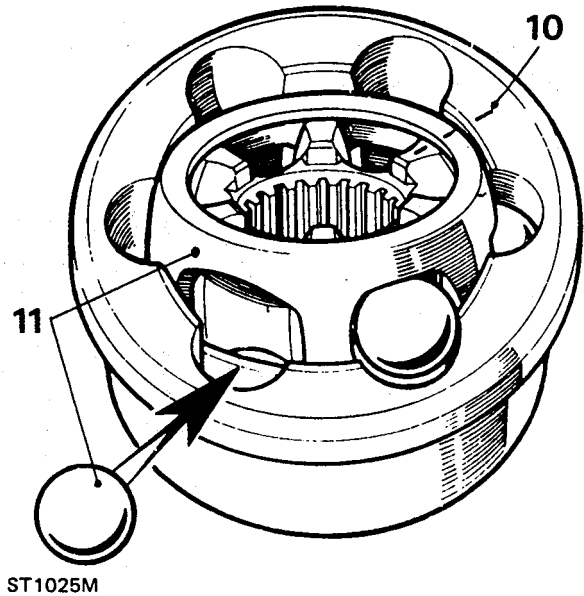

Constant velocity joint

10. Mark positions of constant velocity joint, inner and outer race and cage for reassembly.
11. Swivel cage and inner race to remove balls.



12. Examine all components in particular inner and outer track, cage balls and bearing surfaces for damage and excessive wear.
13. Maximum acceptable end-float on assembled joint 0,64mm, 0.025 in. Renew if worn or damaged. Lubricate with a recommended oil during assembly.

Fit constant velocity joint to axle

14. Fit collar and a new circlip.
15. Engage constant velocity joint on axle shaft splines and using a soft mallet, drive joint in fully.

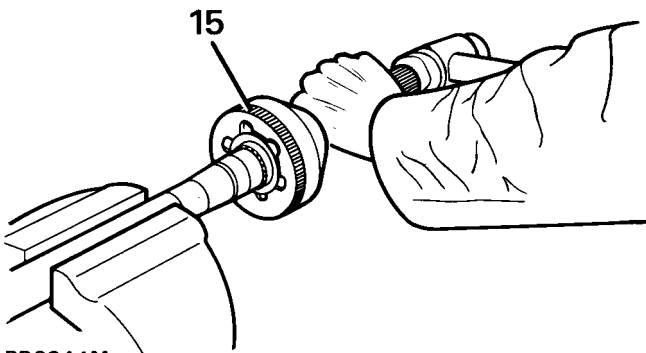

RR3844M

Renew stub axle, thrust ring, oil seal and bearing

16. Drill and chisel off thrust ring taking care to avoid damaging stub axle.

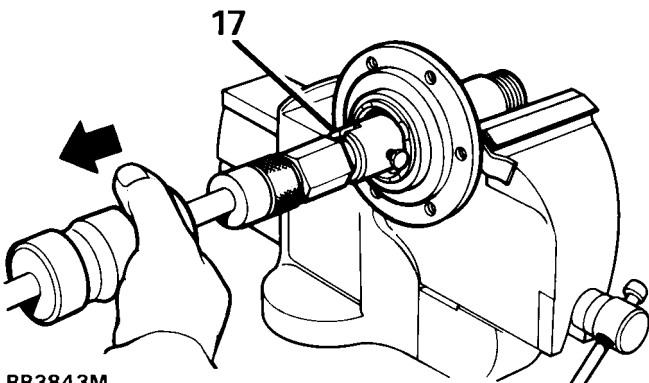

RR3843M

17. Remove bearing and oil seal using special tool **LRT-37-004** and slide hammer **LRT-99-004**. Ensure lip of tool locates behind bearing to drive it out.
18. Repeat instruction for removal of oil seal.

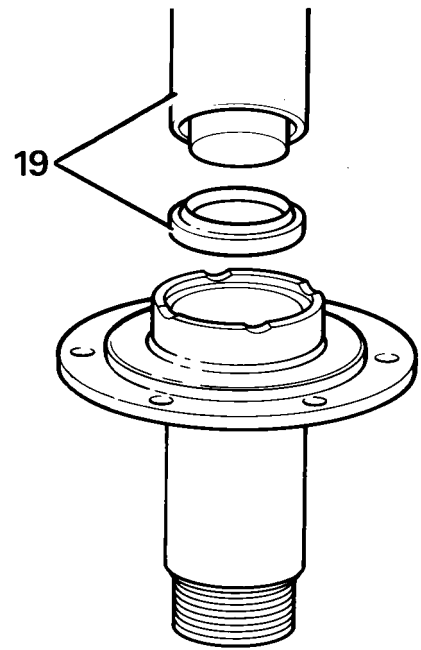

RR3840M

19. Lubricate seal and lip with EP90 oil and with cavity side leading press in a new oil seal using special tool **LRT-54-004**.

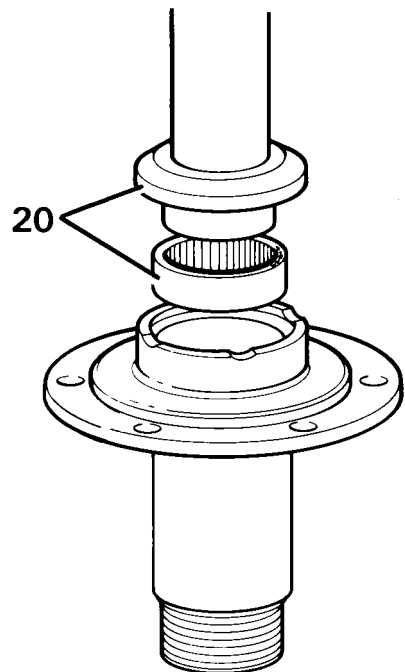

RR3839M

20. Using special tool **LRT-54-005**, fit bearing with its part number visible when fitted, and flush with end face of stub axle.
21. Press fit a new thrust ring onto stub axle.

Swivel pin housing assembly

22. Remove brake disc shield bracket.
23. Disconnect track-rod end ball joint from housing.
24. Disconnect drag-link ball joint.
25. Disconnect jump hoses from brake jump hose bracket.
26. Remove road speed sensor.
27. Remove 6 bolts securing oil seal and retaining plate to swivel pin housing. Prise seal from swivel pin housing.



NOTE: Oil seal and retaining plate cannot be removed until swivel pin bearing housing is removed.

28. Remove 2 screws securing brake damper/shield bracket, and lower swivel pin to housing.
29. Withdraw lower swivel pin and joint washer by tapping protruding lug.
30. Remove top swivel pin retaining bolts complete with brake jump hose bracket.
31. Remove top swivel pin and shims.
32. Remove swivel pin housing while retrieving lower taper bearing.

Swivel pin bearing housing

33. Remove 7 bolts securing swivel pin bearing housing to axle case.
34. Remove and discard oil seal and joint washer.
35. Remove lower swivel pin bearing track.
36. Remove top swivel pin bush housing assembly. Discard two thrust washers and bearing.
37. If worn, pitted or damaged, renew swivel pin bearing housing.
38. Fit a new lower swivel pin bearing track.
39. Fit a new bush and bush housing. Ensure relieved lip of bush housing faces towards rear, as shown.
40. With seal lips trailing press axle shaft oil seal flush into rear of housing. Grease lips.
41. Fit new thrust washers and bearing into top swivel pin bush.
42. Hang swivel pin bearing housing oil seal and retainer plate over back of housing. Ensure they are in correct assembly order.
43. Fit a new joint washer and secure swivel pin bearing housing to axle. Starting with top fixing dowel bolt. Tighten to **72Nm, 52 lbf ft.**

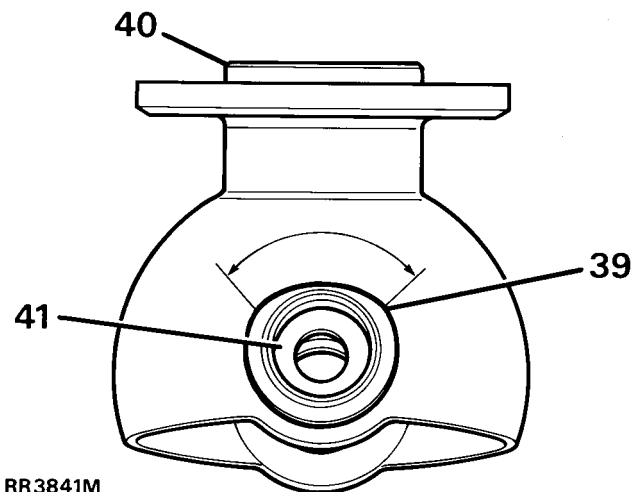

RR3841M

Fit swivel pin housing

44. Grease and fit lower swivel pin bearing to bearing housing.
45. Place swivel pin housing in position over swivel pin bearing housing.
46. Using a new joint washer, fit lower swivel pin with lip outboard. Do not secure with screws at this stage.
47. Fit a new sensor bush and new oil seal, lip side leading to top swivel pin.
48. Lubricate with a recommended oil and fit top swivel pin with existing shims.
49. Coat threads of top swivel pin bolts with Loctite 542. Fit bolts and jump hose bracket (do not tighten).
50. Coat threads of lower swivel pin screws with Loctite 270 and fit, together with damper and shield bracket. Tighten to **25 Nm, 18 lbf ft.**
51. Tighten top swivel pin and brake jump hose bracket securing bolts to **65 Nm, 50 lbf ft.**

Check and adjust preload on bearings

52. The preload on bearings to be **0,25 to 0,30 mm, 0.010 to 0.012 in without** swivel housing oil seal and axle fitted, and reading from centre of swivel pin. The torque required to turn swivel assembly from lock to lock to be **2.0 to 2.8 Nm, 1.5 to 2.0 lbf ft.** Adjust by removing or adding shims as necessary.
53. To take a reading use special tool **LRT-57-024** torque test adaptor, with a torque wrench and extension as shown.

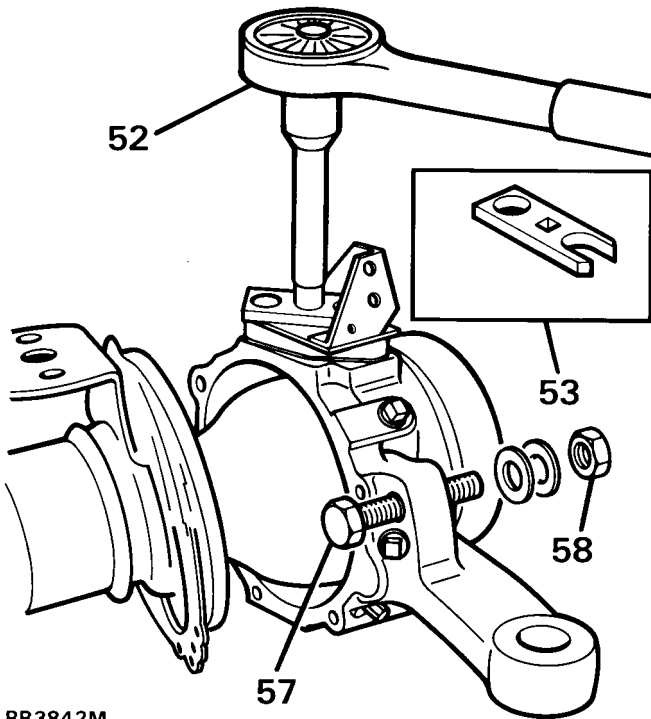

RR3842M

62. Place mud shield in position and secure stub axle to swivel pin housing with six bolts and tighten evenly to **65 Nm, 48 lbf ft.**
63. Fit brake jump hoses to brake jump hose bracket.
64. Fit front hub complete assembly. **See Repair, Front Hub Assembly**
65. Fill swivel assembly with correct amount of lubricant. **See SECTION 10, Maintenance, Under vehicle maintenance .**



NOTE: Vehicles with a filler plug only must be filled with 0.33 Litres, 0.75 pt of Molytex EP 00 grease.

66. Set steering lock stop bolts. **See STEERING, Adjustment, Steering Lock Stops**
67. Fit Wheel speed sensor. **See FUEL SYSTEM, Repair, Wheel speed sensor - Front**

54. Apply a recommended grease between lips of swivel housing oil seal.
55. Secure oil seal with retaining plate and securing bolts. Tighten to **11Nm, 8 lbf ft.**
56. Fit track-rod and drag link and secure with new cotter pins.
57. Loosely fit lock stop bolt for later adjustment.
58. Fit brake disc shield.

Fit driveshaft and stub axle

59. Insert axle shaft, and when differential splines are engaged, push assembly in fully.



CAUTION: Take care not to damage axle shaft oil seals.

60. Place a new joint washer in position on swivel pin housing to stub axle mating face. Coat threads of stub axle bolts with Loctite 270.
61. Fit stub axle with flat at 12 O'clock position.



CAUTION: Ensure that constant velocity joint bearing journal is butted against thrust ring on stub axle before stub axle is secured.



TORQUE VALUES

FRONT AXLE	Nm	lbf/ft
Hub driving member to hub	65*	48*
Brake disc to hub	73	55
Stub axle to swivel pin housing	65*	50*
Brake caliper to swivel pin housing	82	60
Upper swivel pin to swivel pin housing	65*	48*
Lower swivel pin to swivel pin housing	25*	18*
Oil seal retainer to swivel pin housing	11	8
Swivel bearing housing to axle case	73*	55*
Differential drive flange to propeller shaft	47	35
Mudshield to bracket lower swivel pin	11	8
Bevel pinion nut	130	95
Draglink to swivel pin arm	40	30
Panhard rod to axle bracket	88	65
Radius arm to axle bracket	190	140
Radius arm to chassis side member	190	140
Track rod end	40	30
Hub adjusting nut	50	37
Road wheel nuts	130	95

NOTE: * These bolts to be coated with Loctite 270 prior to assembly.





DESCRIPTION

The steering system incorporates a compression joint in the lower shaft and is designed to collapse on impact. The misalignment of the upper steering column with the steering box and the inclusion of two universal joints, is also designed to prevent the column moving towards the driver under frontal impact.

The steering box is located behind the first chassis cross member and is connected to the road wheel swivel housing by a drag link and track rod. An hydraulic damper absorbs shocks in the steering, caused by road wheel deflections when operating on rough terrain.

Power steering system

The power steering system comprises an hydraulic pump which is belt driven from the engine and supplied with fluid from a reservoir that also acts as a cooler.

The steering box houses a self neutralizing rotary valve which is part of the worm/valve assy and an hydraulic piston/rack to assist the mechanical operation. The rotary valve which is operated by movement of the steering wheel, directs fluid pressure to the appropriate side of the hydraulic piston/rack to provide assistance.

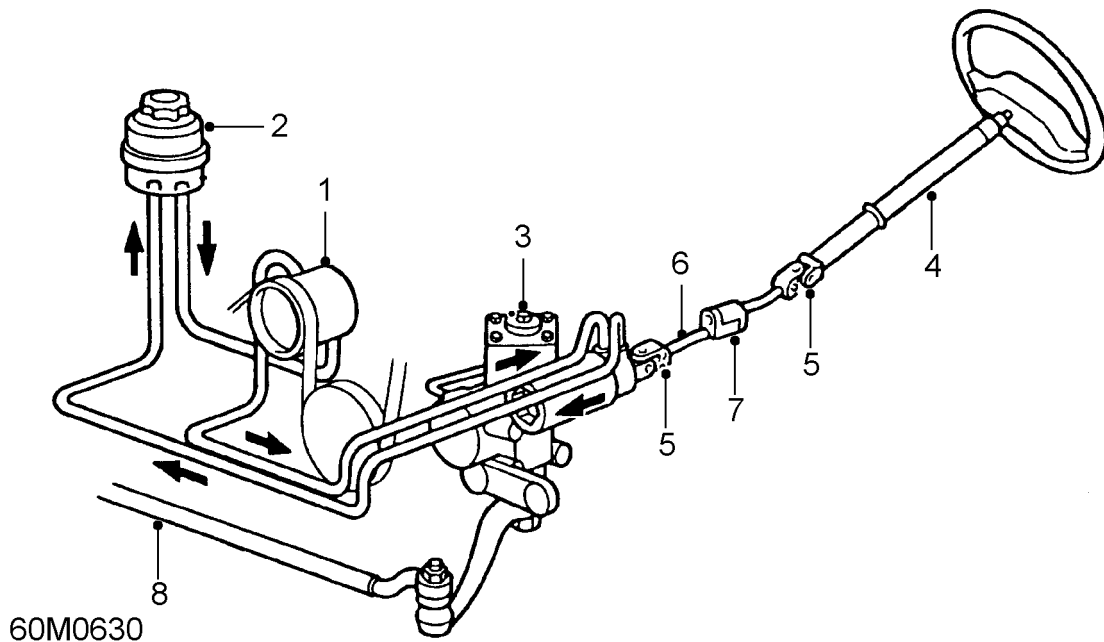

Power steering system

1. Hydraulic pump
2. Fluid reservoir
3. Steering box
4. Upper column
5. Universal joints
6. Lower shaft
7. Compression joint
8. Drag link

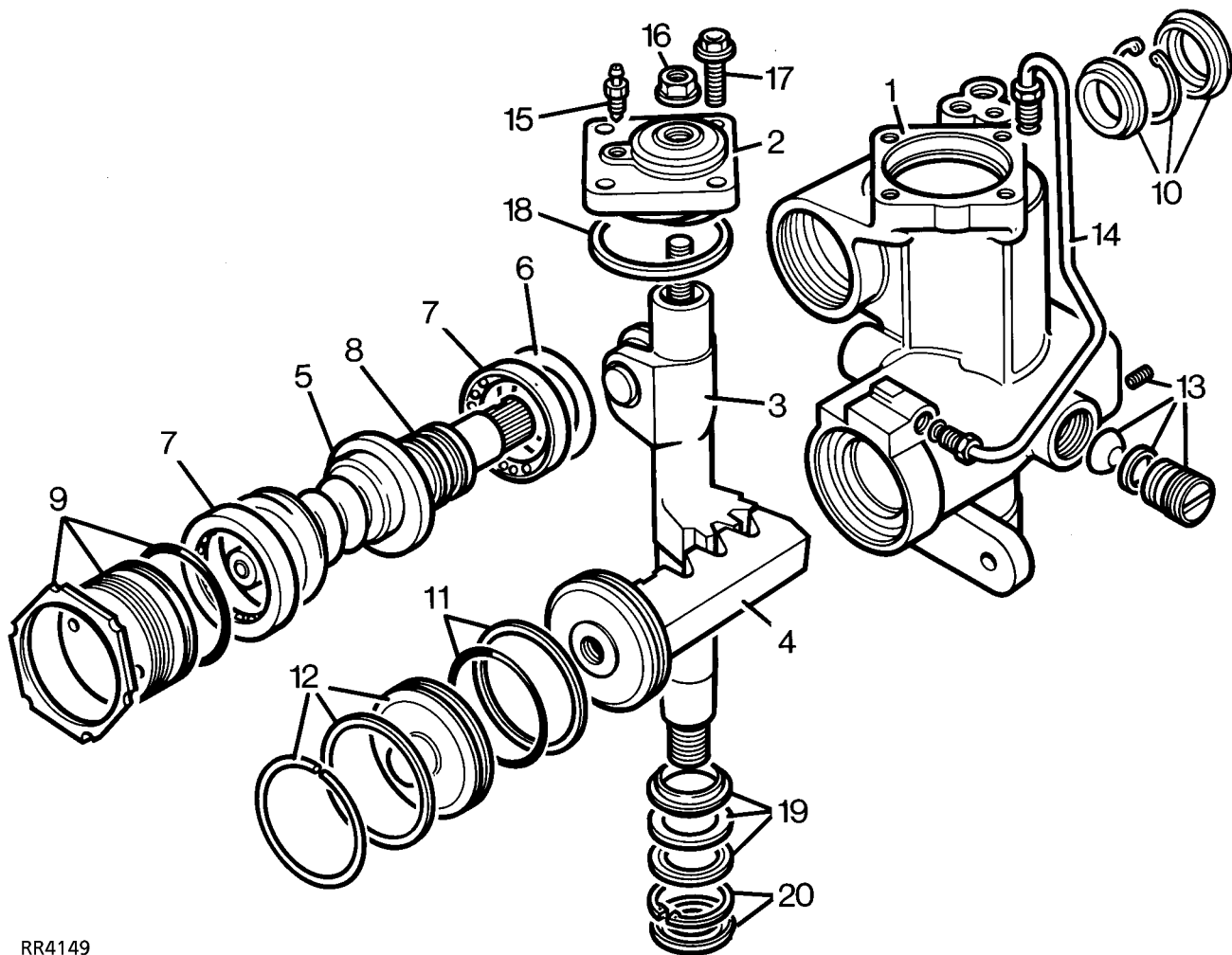

RR4149

Power steering box components

- | | |
|---|--|
| 1. Housing complete with sector shaft bearings | 11. 'Teflon' and rubber seal for piston |
| 2. Cover plate complete with bearing | 12. End cover seal and snap ring |
| 3. Sector shaft | 13. Adjustment components for piston/rack |
| 4. Hydraulic piston/rack | 14. Hydraulic pipe |
| 5. Worm/valve and torsion bar assembly | 15. Bleed screw |
| 6. Shims for centralizing worm/valve | 16. Sector shaft adjustment lock nut with seal |
| 7. Ball race - 2 off | 17. Cover plate bolts - 4 off |
| 8. 'Teflon' seals for valve sleeve - 3 off | 18. Cover plate seal |
| 9. Bearing adjuster, locknut and seal | 19. Seal, washer and backup seal |
| 10. Worm shaft pressure seal, circlip and dirt excluder | 20. Circlip and dust cover |



Rotary valve operation

The rotary valve assembly comprises a worm (1), valve sleeve (2), input shaft (4) and torsion bar (5).

The valve sleeve is retained inside the worm by a trim screw (3), and incorporates valve ports in its inner bore. The input shaft is attached to the steering wheel via a steering shaft and steering column and incorporates valve ports in its outer diameter to align with those in the sleeve. The torsion bar which is secured to the worm and input shaft with pins (6) at each end holds the valve ports in neutral alignment when there is no demand for assistance.

No demand for assistance (Valve at neutral)

When there is no demand for assistance, the torsion bar holds the input shaft and sleeve valve ports in neutral relationship to one another, allowing equal pump pressure 'A' to both sides of the piston/rack (9). Any excess fluid flow from the pump returns to the reservoir via 'B'.

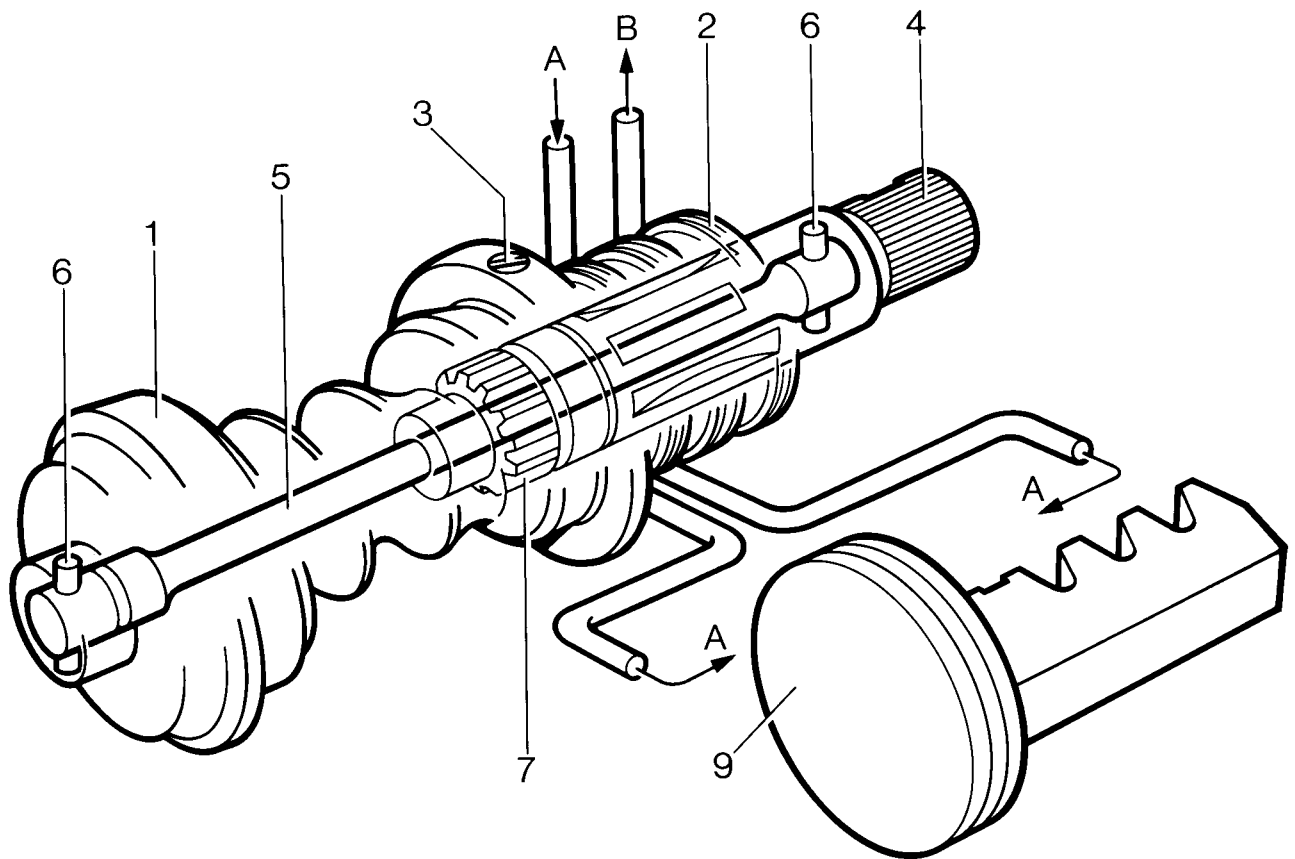

RR3620M

Rotary valve at neutral

Demand for assistance (Valve misaligned)

When the steering wheel and input shaft is turned, steering resistance transmitted to the worm causes the torsion bar to be twisted and the valve ports to be misaligned for a right or left turn. The misalignment of the valve ports directs all fluid pressure 'A' to one side of the piston only and allows displaced fluid 'B' on the other side.

When demanding maximum assistance, any excessive fluid output from the pump due to high pump speed, will circulate through the regulator valve located in the pump unit, causing the temperature of the fluid and the pump to rise rapidly.



CAUTION: To avoid excessive fluid temperatures which could damage the oil seals, the steering must not be held on full lock for more than 30 seconds in one minute.

Only when the steering wheel, and hence the demand for assistance is released, will the torsion bar return the valve to neutral, allowing the fluid to circulate through the reservoir where it is cooled.

In the unlikely event of mechanical failure of the torsion bar, a coarse splined connection (7) between the input shaft and worm, ensures steering control is maintained sufficient to allow the vehicle to be recovered.

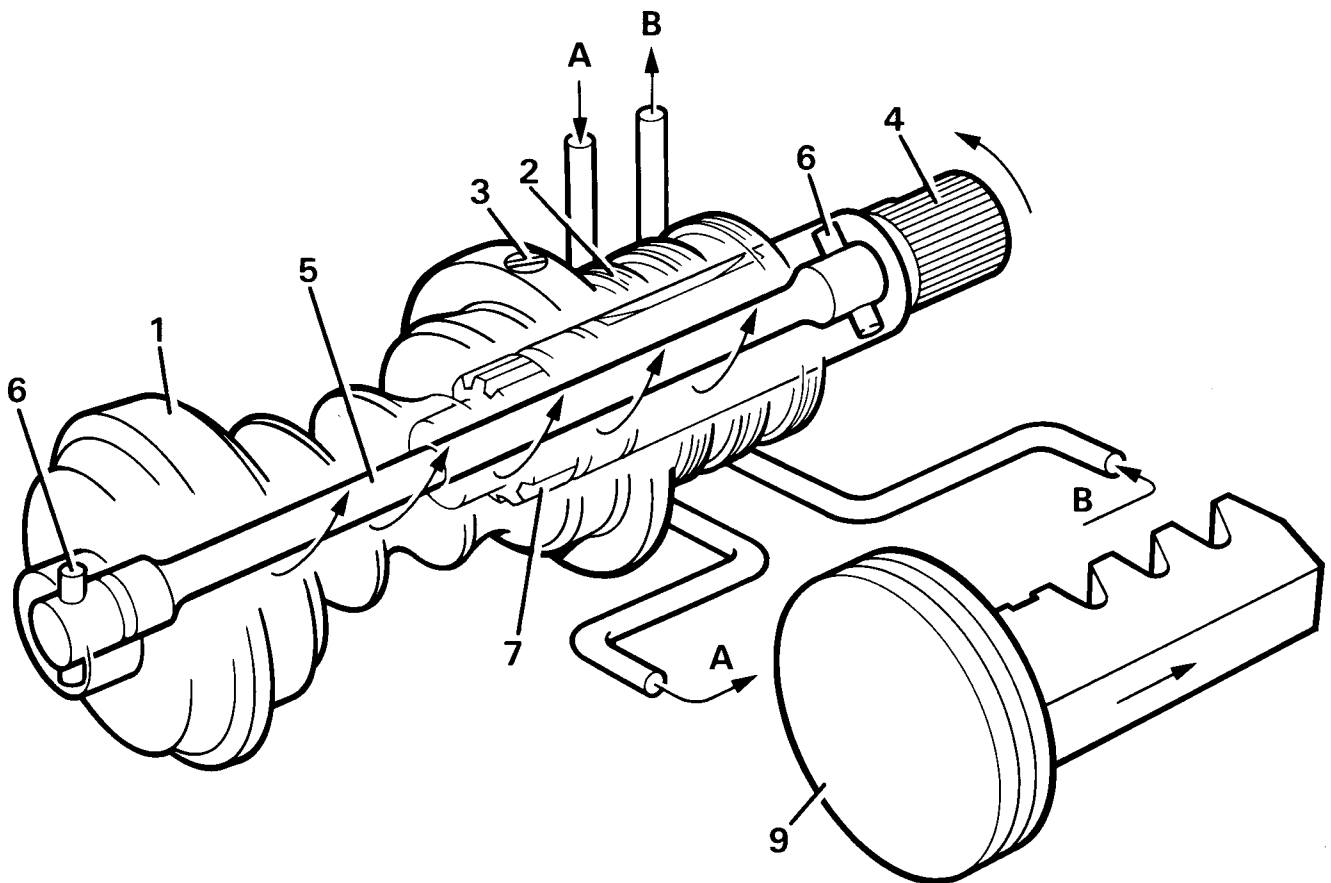

RR3621M

Rotary valve misaligned



Pump and regulator valve operation

The pump which is belt driven from the engine is an eccentric roller type and also houses the pressure regulator and flow control valve. The pressure is controlled by a spring loaded ball valve (3) which is housed inside the flow control valve piston (4).

**No demand for assistance
High flow through box - Low pressure**

With no demand for assistance the rotary valve in the steering box acts as a pressure relief valve, allowing fluid 'A' to flow freely through the steering box and back to the reservoir and pump inlet 'B'.

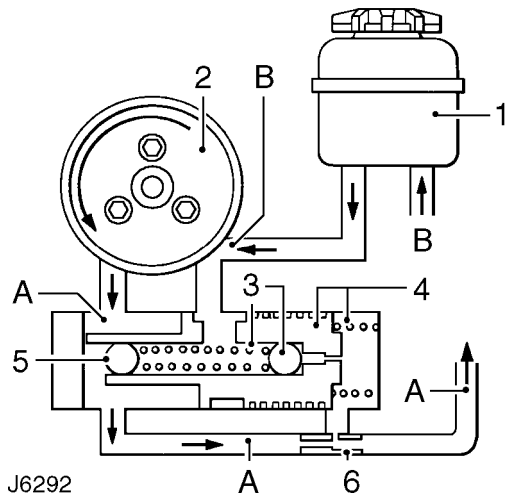

- 1. 1. Reservoir
- 2. 2. Pump
- 3. 3. Pressure control ball valve and spring
- 4. 4. Flow control valve and spring
- 5. 5. Press fit plug (ball bearing)
- 6. 6. Restrictor

The ball plug (5) is pressed into the valve 4 during manufacture and determines the opening pressure of pressure relief valve (3).

**No demand for assistance
No flow, through box - High pressure**

When the steering is turned, the rotary valve effectively stops all fluid flow through the steering box, thus causing an increase in pressure 'A'. This increase in pressure is felt in the flow control valve spring chamber where, at a pre-determined pressure the relief valve (3) will open and allow the pressure to escape. The fall in pressure in the flow control spring chamber, allows the flow control valve to move to the right, which in turn allows pump output 'A' to escape directly into the pump inlet 'B'.

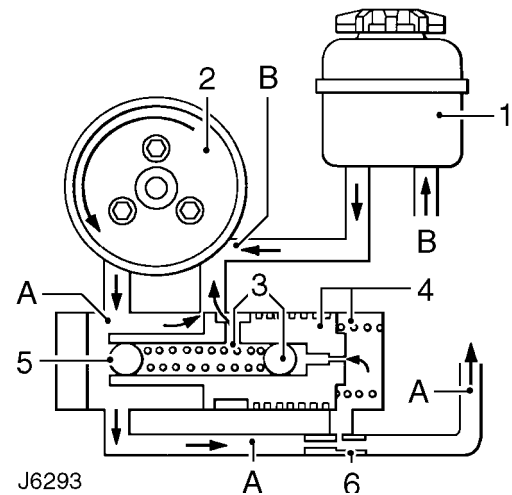

As soon as the steering wheel is released after making a turn, the system reverts to the free flow condition and the road wheels are returned to the straight ahead position by the mechanical steering geometry.

In the event of any hydraulic failure steering control, though heavy, will be maintained through the mechanical components in the steering box.



INSUFFICIENT POWER ASSISTANCE

1. Is fluid level correct?
YES - go to 3.
NO - Fill/bleed system
2. Is problem a leak?
YES - Diagnose **See Power Steering Fluid Leaks** .
NO - continue
3. Is drive belt tension correct?
YES - go to 5.
NO - retension **See ELECTRICAL, Repair, Auxiliary drive belt**
4. Is problem resolved?
YES - end
NO - continue
5. Carry out pressure test at idle and 1000 rev/min.
See Power Steering System - Test .
6. Is correct pressure achieved?
YES - steering box defective
Not at any speed go to 9.
Not at idle go to 7.
7. Is idle speed correct?
YES - Go to 8.
NO - Correct idle speed - **See FUEL SYSTEM, Adjustment, Engine tuning** .
8. Is problem resolved?
YES - end
NO - go to 9.
9. Bypass steering box using adaptor tap
LRT-57-001
10. Is correct pressure obtained?
YES - defective steering box
NO - defective steering pump



CAUTION: Do not hold steering wheel on full lock for more than 30 seconds in any one minute to avoid overheating fluid and possibly damaging seals.



NOTE: 1. Excessive pressure in the system is almost always caused by a faulty relief valve in the PAS pump.



NOTE: 2. Insufficient pressure in the system is usually caused by low fluid level or PAS pump drive belt slip, or one of the following: PAS system leaks, faulty PAS pump relief valve, fault in steering box valve and worm assembly, leak at piston in steering box, worn components in PAS pump or box.

POWER STEERING SYSTEM - TEST



NOTE: If steering lacks power assistance. Check pressure of hydraulic pump before fitting new components. Use fault diagnosis chart to assist in tracing faults.

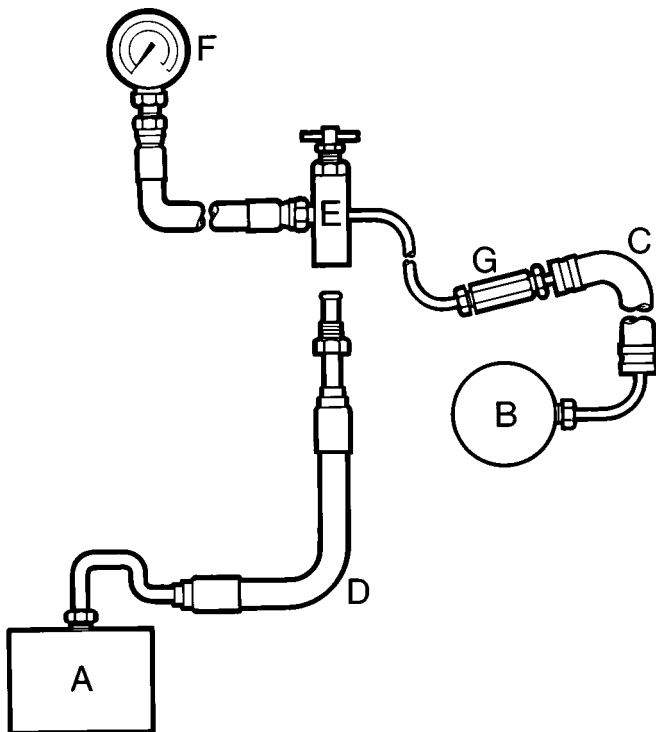

RR3959M

- A. Steering box.
- B. Steering pump.
- C. Existing hose, steering box to pump.
- D. Hose LRT-57-030.
- E. Test adaptor LRT-57-001.
- F. Pressure gauge LRT-57-005.
- G. Thread adaptor LRT-57-004.
- H. Thread adaptor LRT-57-022.

Procedure

1. A hydraulic pressure gauge and test adaptor is used to test power steering system. This gauge is able to measure 140 kgf/cm², 2000 lbf/in². The maximum power steering system pressure is 77 kgf/cm², 1100 lbf/in².
2. Some fault conditions of hydraulic pump may obtain pressures up to 105 kgf/cm², 1250 lbf/in². Pressure on gauge is same pressure being exerted upon steering wheel. When testing, turn steering wheel gradually while reading pressure gauge.
3. Check and maintain maximum fluid level of reservoir.
4. Examine power steering units and connections for leaks. All leaks must be rectified before attempting to test the system.
5. Check steering pump drive belt tension **See ENGINE, Repair, Drive Belt**.
6. Assemble test equipment and fit to vehicle, as shown in RR3959M.
7. Open tap of adaptor.
8. Bleed system, take care not to overload pressure gauge.
9. With system in good condition, pressures should be:
 - (A) Steering wheel held on full lock and engine running at 1,000 rev/min, 70 to 77 kgf/cm², 1000 to 2000 lbf/in².
 - (B) Steering wheel held on full lock and engine idling, 28 kgf/cm², 400 lbf/in².

Checks should be carried out on both full lock positions.



CAUTION: Do not maintain this pressure for more than 30 seconds in any one minute to avoid overheating fluid and possibly damaging seals.

10. Release steering wheel and with engine idling. Pressure should read below 7 kgf/cm², 100 lbf/in².
11. If pressures differ to those given a fault exists.
12. To determine if fault is steering box or pump. Close adaptor tap for a maximum five seconds.
13. If gauge does not register specified pressure, pump is faulty.
14. Fit a new pump, bleed system and repeat test. If low pressure or a substantial imbalance exists, fault is in steering box valve and worm assembly.



STEERING DAMPER

The power steering system, as well as reducing the effort required to manoeuvre the vehicle when parking, also helps to dampen any deflections of the road wheels, being transmitted back to the steering wheel.

When operating the vehicle off road, the road wheels are often deflected by ruts and boulders causing the steering wheel to turn left and right. This phenomenon is known as 'steering kickback'. To subdue the effects of 'steering kickback', a hydraulic damper is fitted in the steering linkage between the track rod and the differential casing. The damper, which offers the same resistance in extension and compression, is sealed for life.

Steering damper check

Check the condition operation of the hydraulic steering damper as follows:

Check procedure

1. Inspect damper for casing damage or leaks.
2. Clamp one end of the damper horizontally in a vice using soft jaws. Compress and extend the unit by hand. Resistance should be equal in both directions.
3. If it is felt that the unit is outside acceptable limits, fit a new steering damper

STEERING FAULTS

Symptom:-

Excessive kickback through steering wheel - when driven on rough terrain.

1. Is the steering damper in good working order?
See Steering Damper.
NO - Renew unit **See Repair, Steering Damper.**
YES - Continue.
2. Is there any looseness or free play in the steering ball joints and linkage?
YES - **See Steering Linkage Inspect.**
NO - Continue.
3. Is there any looseness or worn bushes in front suspension?
YES - **See FRONT SUSPENSION, Repair, Radius Arm.**



NOTE: When replacing suspension bushes ALL bushes and fixings must be replaced.

NO - Continue.

4. Is the steering exceptionally light/sensitive when driven on good road surface?
YES - See fault symptom - **Steering excessively light/sensitive and freeplay at steering wheel.**
NO - Suspect axle swivel resistance.
5. Check the resistance of the axle swivels **See FRONT AXLE AND FINAL DRIVE, Overhaul, Front Stub Axle, Constant Velocity Joint and Swivel Pin Housing.**

Symptom:-

Fluid leaks from steering box seals.



CAUTION: The steering wheel must not be held on full lock for more than 30 seconds in one minute, as this may overheat the fluid and cause damage to the oil seals.

1. Check fluid level *See Repair, Power Steering Fluid Reservoir.*
Check fluid pressure *See Power Steering System - Test.*
2. Is pressure high?
YES - Renew pump *See Repair, Power steering Pump.*
If oil seal leaks persist after renewing the pump *See Overhaul, Power Steering Box.*
NO - *See Overhaul, Power Steering Box.*

Symptom:-

Insufficient power assistance - castor return action normal.

1. Are tyres correct type and pressure?
NO - *See GENERAL SPECIFICATION DATA, Information, Wheels and Tyres.*
YES - Continue.
2. Is fluid level correct?
NO - Check fluid level *See Repair, Power Steering Fluid Reservoir.*
YES - Check system for air locks *See Repair, Power Steering System - Bleed.*
3. Is pressure correct?
NO - Check fluid pressure *See Power Steering System - Test.*
If pressure is not correct after bleeding the system, renew pump *See Repair, Power Steering Pump.*
YES - *See Overhaul, Power Steering Box.*

Symptom:-

Steering heavy - stiff, poor castor return action.

1. Are tyres correct type and pressure?
NO - *See GENERAL SPECIFICATION DATA, Information, Wheels and Tyres.*
YES - Check universal joints for seizure and correct alignment *See Repair, Lower Steering Shaft and Universal Joints .*
Check power steering box adjustments *See Overhaul, Power Steering Box.*
2. Is the power assistance satisfactory?
NO - See fault symptom **Insufficient assistance, (castor return action normal).**
YES - Disconnect drag link from drop arm and check steering column and box for stiffness *See Repair, Drag Link and Drag Link Ends.*
3. Is the steering stiff with the drag link disconnected?
NO - Check steering ball joints for seizure and axle swivels lubrication and resistance *See Repair, Drag Link and Drag Link Ends , See FRONT AXLE AND FINAL DRIVE, Overhaul, Front Stub Axle, Constant Velocity Joint and Swivel Pin Housing.*
YES - Disconnect the lower steering shaft and check the column and box for stiffness *See Repair, Lower Steering Shaft and Universal Joints.*
4. Is the steering column stiff to turn when disconnected from the box?
NO - Remove and overhaul box *See Overhaul, Power Steering Box.*
YES - Adjust steering column *See Stiff Steering Checklist.*

**Symptom :-**

Steering excessively light/sensitive. Excessive freeplay at steering wheel.

1. Are steering box adjustments correct?
NO - **See Adjustment, Power Steering Box.**



WARNING: Adjustments of steering box should not be required while in warranty period. If box is within warranty, it must be returned to manufacturer. No attempt must be made to introduce backlash.

YES - Suspect worn panhard rod or radius arm bushes. Check condition of ball joints and the lower steering column shaft universal joints for wear See Repair, Lower Steering Shaft and Universal Joints.

Symptom :-

Steering vibration, road wheel shimmy - wobble.

Vibration through the steering linkage powerful enough to induce high frequency oscillation of the steering wheel, is generally caused by out of balance road wheels. However there are a number of other possible causes of this symptom which if severe, may be described as shimmy or wobble. Regardless of the terminology used by the owner/driver to describe the symptoms, the following diagnostic checks should be carried out in the order presented.

1. Check the tyres and balance of the road wheels **See GENERAL SPECIFICATION DATA, Information, Wheels and Tyres, See WHEELS AND TYRES, Fault diagnosis, Fault - Symptoms See WHEELS AND TYRES, Repair, Wheel Balancing.**
2. Check the steering hydraulic damper function **See Steering Damper.**
3. Check steering column universal joints for wear and correct alignment **See Repair, Lower Steering Shaft and Universal Joints.**
4. Check steering linkage ball joints for wear, correct alignment and security, including steering box and tie rod, **See Steering Linkage Inspect.**
5. Check all front suspension rubbers for wear. Check all fixing torques, including radius arm bushes, panhard rod and anti-roll [sway] bar **See FRONT SUSPENSION, Repair, Panhard Rod, See FRONT SUSPENSION, Repair, Radius Arm, See FRONT SUSPENSION, Repair, Anti-Roll Bar Assembly, See FRONT SUSPENSION, Repair, Front Shock Absorber.**
6. Fit new radius arm bushes using NTC 6860. Fit new nuts, bolts and washers.
7. If problem persists fit damper kit STC 241 (2 off front) and STC 1474 (2 off rear). Road test vehicle.
8. Check the power steering box adjustments and operation **See Overhaul, Power Steering Box.**
9. Check the hub bearing end floats and determine the condition of the hub bearings as applicable **See FRONT AXLE AND FINAL DRIVE, Repair, Front Hub Assembly.**
10. Check the resistance and condition of the swivels **See FRONT AXLE AND FINAL DRIVE, Description and operation, Description.** If problem is not diagnosed: Repeat checks starting at 1.
11. Carry out a full steering geometry check **See INTRODUCTION, Information, Steering.**

STEERING STABILITY AND VEER UNDER BRAKING

Possible cause:

Incorrectly set, swivel pin bearing preload.

Remedy.

1. Follow instructions to overhaul front stub axle, constant velocity joint and swivel pin **See FRONT AXLE AND FINAL DRIVE, Overhaul, Front Stub Axle, Constant Velocity Joint and Swivel Pin Housing.**

1. GENERAL STEERING

1. Carry out visual and safety checks **See Visual and Safety Checks.**
2. Road test vehicle **See Road Test Procedure .**
3. Is problem resolved?
YES - end
NO - continue
4. Is problem stiff steering?
YES - **See Stiff Steering Checklist .**
NO - Go to 6.
5. Is problem resolved?
YES - end
NO - go to 8.
6. Is problem steering niggles ?
YES - Replace radius arm bushes, arm and axle
See FRONT SUSPENSION, Repair, Radius Arm.
NO - go to 8.
7. Is problem resolved?
YES - end
NO - continue.
8. Centralise steering box **See Adjustment, Centralise Steering Box.**
9. Is problem resolved?
YES - end
NO - continue.
10. Check, adjust if necessary, steering geometry.
11. Is problem resolved?
YES - end
NO - continue.
12. Categorise the remaining problems into one or more of the following descriptions:
See 2. Steering Veer .
See 3. Veer Under Braking .
See 4. Directional Stability .



2. STEERING VEER

From 1. GENERAL STEERING:

1. Vehicle veers, not under braking, swap front tyres side to side.
2. Is problem resolved?
YES - end
NO - continue.
3. Does vehicle now veer in other direction?
YES - fit new tyres
NO - continue.
4. Recentralise steering box **See Adjustment, Centralise Steering Box.**
5. Is problem resolved?
YES - end
NO - contact local technical office.

3. VEER UNDER BRAKING

From 1. GENERAL STEERING:

1. Vehicle veers under braking, bleed brake system.
2. Is problem resolved?
YES - end
NO - continue.
3. Check brake pads for glazing, and discs, axles etc for contamination.
4. Is problem resolved?
YES - end
NO - continue.
5. Check brake lines and hoses for deterioration. Replace as necessary.
6. Is problem resolved?
YES - end
NO - continue.
7. Contact Technical Support Office.

4. DIRECTIONAL STABILITY

From 1. GENERAL STEERING:

1. Is directional stability concern when vehicle is towing?
YES - Check towing/vehicle loading parameters in Owner's Handbook.
NO - go to 3.
2. Is problem resolved?
YES - end
NO - continue.
3. Check condition of rear trailing link/chassis bushes.
4. Is problem resolved?
YES - end
NO - continue.
5. Check condition of front and rear shock absorbers. If in doubt change units in pairs, side to side.
6. Is problem resolved?
YES - end
NO - continue.
7. Check steering damper **See Steering Damper.**
8. Is problem resolved?
YES - end
NO - continue.
9. Check wheel balance
10. Is problem resolved?
YES - end
NO - contact local technical office.

POWER STEERING FLUID LEAKS

1. Is fluid level correct?
YES - go to 3.
NO - Refill or drain to correct level. Bleed system, check for leaks **See Repair, Power Steering System - Bleed.**
2. Is problem resolved?
YES - end
NO - continue.
3. Are hoses or joints leaking? Check on full lock with engine at 2000 rev/min.
YES - loosen and retorque joints.
NO - go to 6.
4. Does leak remain?
YES - change PAS pipe.
NO - end.
5. Does leak remain?

YES - suspect seal in component. Check and replace as necessary.

NO - end.
6. Is oil escaping from filler cap?
YES - bleed system **See Repair, Power Steering System - Bleed.**
NO - go to 8.
7. Is oil still escaping from filler cap?
YES - go back to 1.
NO - end.
8. Is oil leaking from PAS pump?
YES - go to 10.
NO - continue.
9. Is oil leaking from PAS box?
YES - go to 10.
NO - end.
10. Clean unit, add tracer dye to system. Retest
11. Is oil still leaking?
YES - establish leak point. Repair or replace unit as necessary.
NO - end.



POWER STEERING SYSTEM - EXCESSIVE NOISE

1. Is fluid level correct?
YES - go to 3.
NO - Refill or drain to correct level. Bleed system, check for leaks **See Repair, Power Steering System - Bleed.**
2. Is problem resolved?
YES - end
NO - continue.
3. Is pressure hose from pump to box touching body in a hard foul condition?
YES - reroute hose away from body.
NO - go to 5.
4. Does noise remain?
YES - continue.
NO - end.
5. Is noise a whistle or hiss on full lock?
YES - noise is not a fault unless excessive. Compare with other vehicles
NO - go to 8.
6. Is noise excessive?
YES - continue.
NO - end.
7. Change steering box and/or pump.
8. Is noise a squeal on full lock?
YES - check drive belt tension **See ELECTRICAL, Repair, Auxiliary drive Belt.**
NO - go to 10.
9. Does squeal remain?
YES - drive belt contaminated, change belt **See ELECTRICAL, Repair, Auxiliary drive belt.**
NO - end.
10. Is noise a continuous moan?
YES - bleed PAS system **See Repair, Power Steering System - Bleed.**
NO - go to 13.
11. Does moan remain?
YES - do figure 8 manoeuvres.
NO - end.
12. Does moan remain?
YES - continue
NO - end.

13. Is noise an intermittent "grunt"?
YES - **See Power Steering System - Grunt.**
NO - continue.
14. Is it a clunking noise?
YES - check drive belt tension **See ELECTRICAL, Repair, Auxiliary drive Belt.**
NO - contact local technical office.
15. Does noise remain?
YES - Suspect suspension or drive train.
NO - end.

POWER STEERING SYSTEM - GRUNT

Steering box grunts intermittently when turning from lock to lock:

1. Is fluid level correct?
YES - go to 3.
NO - refill or drain to correct level. Bleed system, check for leaks **See Repair, Power Steering System - Bleed.**
2. Does grunt remain?
YES - continue
NO - end.
3. Is correct low pressure hose, steering box to reservoir fitted?
YES - go to 5.
NO - Fit correct hose.
4. Does grunt remain?
YES - continue
NO - end.
5. Purge box by doing figure 8 manoeuvres e.g. on car park, followed by 10 minutes normal road use.
6. Does grunt remain?
YES - Contact local technical office
NO - end.

VISUAL AND SAFETY CHECKS



WARNING: Before taking vehicle out on the public highway for road test, it is important that the following basic visual checks are carried out to ensure that the vehicle complies with legal requirements.

Tyres and wheel rims

1. Check and adjust tyre pressures **See GENERAL SPECIFICATION DATA, Information, Tyre Pressures.**
Note that this information refers to standard tyres fitted as original equipment.
2. Check condition of tyres. Inspect for signs of uneven wear, damage and feathering. Check tread depth.
3. Ensure that the tyre make, type and general condition are common across each axle.
4. Check wheel rims for signs of damage and excessive run out.
5. Carry out road test **See Road Test Procedure.**

ROAD TEST PROCEDURE

General steering/handling problems can usually be classified into one of the categories listed and ARE GENERALLY RELATED TO THE AGE, CONDITION AND USE OF THE VEHICLE.



WARNING: Ensure that all road tests are conducted by suitably qualified drivers in a safe and legal manner, and where local traffic conditions allow.

1. Carry out visual and safety checks **See Visual and Safety Checks .**

Confirm general nature of complaint with customer, simulating where possible the conditions under which the problem occurs. Carry out following road test procedure to establish the problem.

2. Steering load assessment - drive at 15 km/h, 10 mph. Put 90°turn input into steering wheel, check self centering. The self centering should be equal on each lock but not necessarily return to exactly straight ahead without assistance from the driver.
3. Steering assessment - drive at 65 km/h, 40 mph on a straight FLAT road (no camber), check for steering veer. The vehicle should follow a straight path with NO tendency to follow a curved path. If vehicle veers towards the kerb, vehicle may be 'camber sensitive'. A small amount of veer in direction of camber is acceptable.
4. Directional stability assessment - drive at 110 km/h, 70 mph or maximum legal speed on a straight flat road. Carry out a normal lane change. Vehicle should quickly settle into a new straight path.
5. Braking assessment (medium effort) - drive at 95 km/h (60 mph) on a straight flat road. Apply steady medium braking effort, noting any tendency to veer. Carry out brake test three times, if a veer is consistently noted carry out a braking efficiency test on a rolling road.
6. Braking assessment (full effort) - drive at 95 km/h, 60 mph on a straight flat road. Apply full braking effort, noting any tendency to veer. Carry out brake test 3 times, if a veer is consistently noted carry out a braking efficiency test on a rolling road.

If the symptom described by the customer is stiff steering or steering niggles, carry out stiff steering procedure **See Stiff Steering Checklist.**

If not, proceed with basic checks and adjustments **See Visual Check and Basic Adjustments .**



STIFF STEERING CHECKLIST



NOTE: Having completed visual checks and steering assessment and confirmed that vehicle steering load is incorrect carry out the following procedure in order shown.

Steering wheel 'torque to turn' loads

1. Raise vehicle so both front wheels free.
2. With engine off, centralise steering wheel, and remove steering wheel pad. Using torque wrench on column nut, check torque required to turn the steering wheel one turn in each direction.
3. Record readings obtained in each direction. Reading should be **4.4 Nm, 3.5 lbf ft**.



NOTE: If figures are in excess of that specified carry out steering box tie bar reset below. If figures are as specified See Visual Check and Basic Adjustments.

Steering box tie bar reset

1. Loosen the tie bar fixings one complete turn.
2. Drive vehicle carefully a short distance, within the dealership, applying full lock in both directions in order to settle steering components. Drive vehicle over speed bumps and include harsh braking if possible.



WARNING: Do not drive on public highway.

3. Near end of 2. ensure vehicle is driven in a straight line on level ground and halted.
4. Tighten panhard rod mounting arm nut to **110 Nm, 80 lbf ft**.
5. Tighten the 2 fixings, tie bar to steering box, to **80 Nm, 60 lbf ft**.
6. Recheck steering wheel torque to turn. If torque reading is still greater than specified, carry out steering shaft universal joint lubrication.

Lower steering shaft universal joint lubrication

1. Check lower steering shaft is correctly phased **See Repair, Lower Steering Shaft and Universal Joints.**
2. Lubricate universal joints with an anti-seizure type penetrating spray. Work the joints to ensure full penetration of the spray by driving vehicle and steering from lock to lock.
3. If steering stiffness still persists carry out swivel pin preload setting.

Swivel pin preload setting

1. The swivel pin preload setting must be checked and set **See FRONT AXLE AND FINAL DRIVE, Overhaul, Front Stub Axle, Constant Velocity Joint and Swivel Pin Housing.**
Note that a pull load of 1.16 - 1.46 kg, 2.5 - 3.2 lb is required after the axle shaft and swivel housing seal have been removed.

Steering box adjustment

1. Check steering box adjustment **See Adjustment, Power Steering Box.**

Steering damper check

1. Check condition of steering damper **See Steering Damper.**

VISUAL CHECK AND BASIC ADJUSTMENTS



NOTE: It is important that the following instructions are carried out in the sequence shown and the results recorded.

1. Road springs - check that road springs are correctly seated and are to correct specification for vehicle. For spring specification **See GENERAL SPECIFICATION DATA, Information, Road Springs Data.**
2. Ride height - measure trim height from wheel centre to wheelarch eyebrow. Record results on Check Sheet.
3. Check/top up power steering fluid **See Repair, Power Steering Fluid Reservoir.**
4. Check tension and condition of drive belt **See ELECTRICAL, Repair, Auxiliary drive Belt.**
5. Track rod/drag link - check condition of track rod, drag link and ball joints **See Repair, Drag Link and Drag Link Ends.**
If either component is damaged, check operation of steering damper and steering box for smoothness. Replace all damaged or worn components that impair the operation of the steering system.
6. Suspension bushes - examine all steering and suspension bushes for signs of wear and deterioration. Also check all fixings for torque relaxation. Tighten to correct torque value **See FRONT SUSPENSION, Specifications, torque, Torque Values.**
7. Oil leaks - check front and rear axle hubs for leak and repair as necessary.
8. Brake system - check brake system for leaks, pipe condition, pad wear/contamination, disc wear/condition.
9. Hub end float - check movement in the hubs by rocking the wheels.

10. Check front wheel alignment. Vehicles displaying a tendency to veer more than considered allowable, it is permissible to set the front track to parallel.
11. Having completed all the above checks and adjustments, road test vehicle **See Road Test Procedure .**
Attempt to reproduce the symptoms established earlier. If symptoms still exist refer to relevant Diagstic Chart.

STEERING LINKAGE INSPECT



NOTE: When inspecting steering linkages and ball joints for wear the following items must be checked.

Steering ball joints

1. Check ball joint rubber boots for security, signs of cracking or deterioration.
2. Check ball joint assemblies for seizure i.e. no movement on ball joint and associated assemblies.
3. Check for excessive wear. This will be evident as extreme movement on track rod and steering linkages. Renew parts as necessary **See Repair, Track Rod and Linkage, See Repair, Drag Link and Drag Link Ends.**

Steering linkages

1. Check all linkages for wear, deterioration and damage. Renew parts as necessary **See Repair, Track Rod and Linkage, See Repair, Drag Link and Drag Link Ends.**



POWER STEERING BOX - ADJUST

Service repair no - 57.35.01



WARNING: Adjustments of steering box should not be required while in warranty period. If box is stiff or tight and within warranty, it must be returned to manufacturer. No attempt must be made to introduce backlash.

1. Apply park brake brake, select 'P' and chock road wheels.
2. Jack up front of vehicle until wheels are clear of ground.
3. Support chassis front on axle stands.
4. Disconnect drag link from steering drop arm.
5. Centralise steering box **See Power Steering Box - centralise**



NOTE: Only check for no backlash when steering box is in central position.



NOTE: If steering wheel is not straight, it should be repositioned.

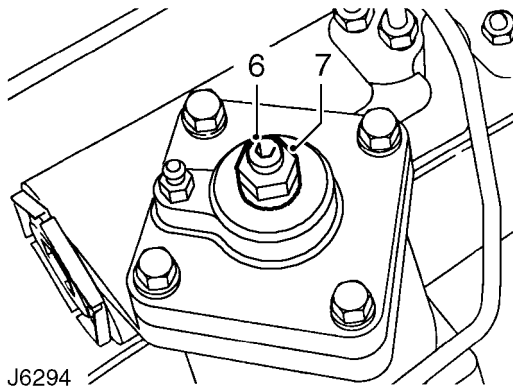

6. Adjustment is obtained by rocking the drop arm about centre whilst an assistant slowly tightens the steering box adjuster screw.
7. Tighten locknut when all backlash has been removed.

8. Repeat the check for backlash. If backlash exists loosen locknut and repeat adjustment procedure.
9. Turn steering wheel lock to lock and check no tightness exists.
10. Ensure front wheels are aligned and in straight ahead position.
11. Adjust drag link 924 mm, 36.2 in between ball joint centres.
12. Connect drag link and tighten to **40 Nm, 30 lbf ft.**
13. Lower vehicle to ground level and remove chocks.
14. Road test vehicle .

Drag link adjust

1. If steering wheel is to right, drag link is too short. If steering wheel is to left drag link is too long.
2. Adjust drag link until steering wheel points straight ahead when vehicle is travelling in a straight line.

STEERING LOCK STOPS

Service repair no - 57.65.03

Check

1. Measure clearance between tyre wall and radius arm at full lock. This must be not less than 20 mm, 0.79 in.

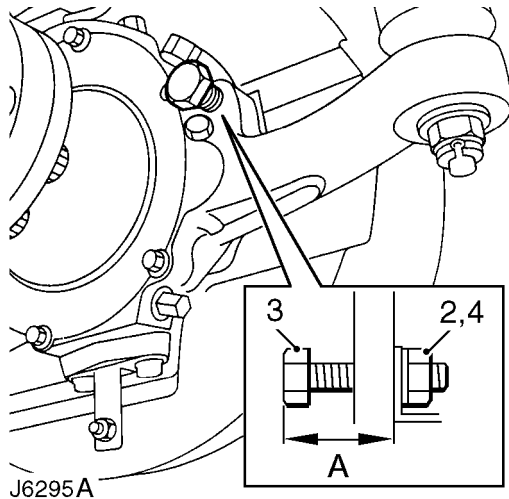

J6295A

Adjust

2. Loosen stop bolt locknut.
3. Turn stop bolt as required.
4. Tighten locknut.
5. Check clearance between tyre wall and radius arm on each lock.



NOTE: Alternatively lock stop adjustment may be carried out using following procedure.

Check

6. Measure stop bolt protrusion 'A', this must be 59.7 mm, 2.35 in.

Adjust

7. Loosen stop bolt locknut.
8. Turn stop bolt as required.
9. Tighten locknut.
10. Check wheel position at full lock.

FRONT WHEEL ALIGNMENT

Service repair no - 57.65.01

Checking Toe-out dimensions



NOTE: Recognised front wheel alignment and tracking equipment should be used for this operation. Only the use of basic equipment is described below. No Adjustment is provided for castor, camber or swivel pin inclinations.

1. Set vehicle on level ground with road wheels positioned straight ahead.
2. Push vehicle back and forwards to settle linkage.
3. Set up the equipment to manufactures instructions and check alignment as advised by equipment supplier.

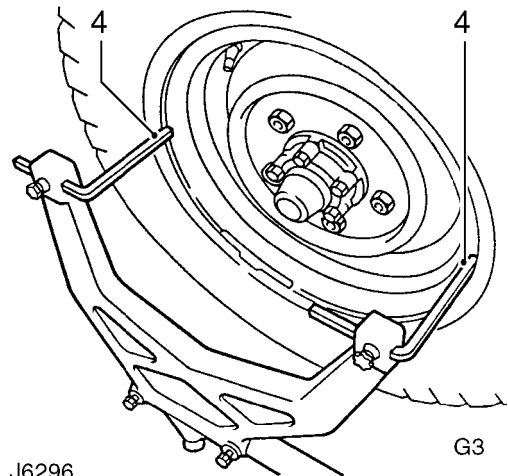

J6296

G3

4. Position trammel probes on inner face of wheel, not the rims, if the latter are damaged.
5. Measure toe-out at horizontal centre-line of wheels.
6. Check tightness of clamp bolt fixings. Tighten to **14 Nm, 10lbf ft.**

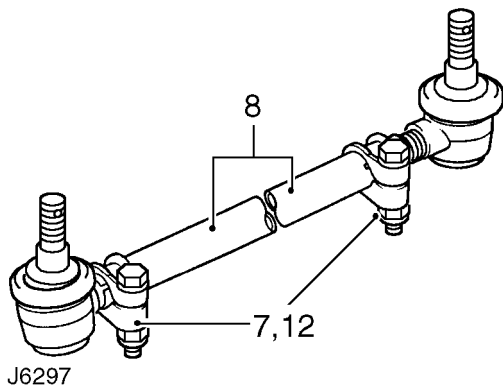

Adjust

7. Loosen clamps at both ends of track rod.
8. Rotate track rod to increase or decrease its effective length until correct toe-out is obtained
See GENERAL SPECIFICATION DATA, Information, Steering.
9. Push vehicle rearwards turning steering wheel from side to side to settle ball joints. With road wheels set in straight ahead position, push vehicle forward a short distance.
10. Recheck track and adjust if necessary.
11. When alignment is correct, tap ball joints in direction of arrows to maximum of travel, to ensure full unrestricted movement of track rod.
12. Tighten clamp bolts to **14 Nm, 10 lbf ft**.

POWER STEERING BOX - CENTRALISE

Service repair no - 57.35.05

Adjust

1. Raise vehicle on ramp [hoist].

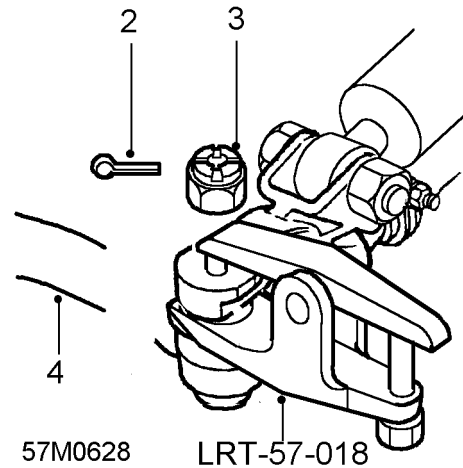

2. Remove split [cotter] pin from castellated nut securing drag link to drop arm.
3. Remove castellated nut.
4. Using tool **LRT-57-018** release drop arm from drag link.
5. Turn steering wheel to full RH lock.
6. Turn steering wheel back exactly 2 turns.
7. Fit drop arm to drag link and fit castellated nut.
8. Tighten castellated nut to **40 Nm, 30 lbf ft** and fit new split [cotter] pin.
9. Lower vehicle.

POWER STEERING SYSTEM - BLEED

Service repair no - 57.15.02

Check

1. Position container to collect any fluid spillage.
2. Ensure fluid in reservoir reaches dipstick maximum.
3. Run engine to normal operating temperature.
4. Recheck and correct reservoir fluid level.



NOTE: During instructions 4 to 6, maintain maximum fluid level in reservoir. Do not increase engine speed or move steering wheel.

wheel.

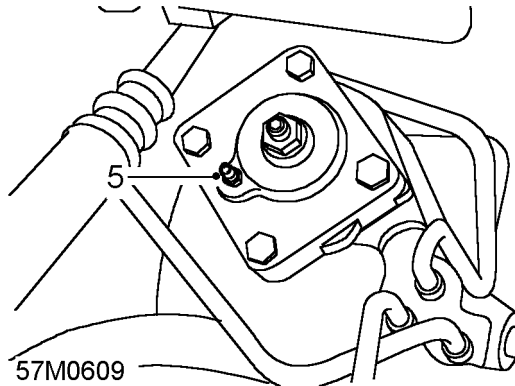

5. With engine at idle speed, loosen bleed screw on steering box. Tighten bleed screw when fluid emerges.
6. Check fluid level.
7. Fit reservoir cap.
8. Clean away fluid around bleed screw.
9. Check hose connections, pump and steering box for fluid leaks by holding steering on full lock in both directions.



CAUTION: Do not maintain this pressure for more than 30 seconds in any one minute to avoid overheating fluid and possibly damaging seals.

10. Remove container.
11. Carry out road test.



POWER STEERING BOX

Service repair no - 57.10.01

General precautions

- Whenever any part of the system is removed or disconnected, utmost cleanliness must be observed.
- Disconnected ports and hoses must be plugged to prevent ingress of dirt. If metal sediment is found in system, establish the cause, rectify and flush system.
- Do not start engine until reservoir is full as pump will be damaged.
- Metric pipe fittings are used with 'O' ring pipe ends on fittings to steering box.
- Follow normal 'O' ring replacement procedure whenever pipes are disconnected.
- Ensure compatible metric components are used when fitting replacement pipes.



CAUTION: After refitting steering linkage parts, follow correct procedure to ensure that road wheels, steering box and steering wheel are correctly positioned relative to each other when in the straight ahead condition.



NOTE: When drag link is disconnected from steering box, travel available at steering wheel to each full lock is not equal.

Remove

1. Raise vehicle on ramp.
2. Remove panhard rod. *See FRONT SUSPENSION, Repair, panhard rod*
3. Remove bolt securing steering damper to drag link.
4. Release steering damper from drag link.
5. Remove split pin from castellated nut securing drag link to drop arm.
6. Remove castellated nut.

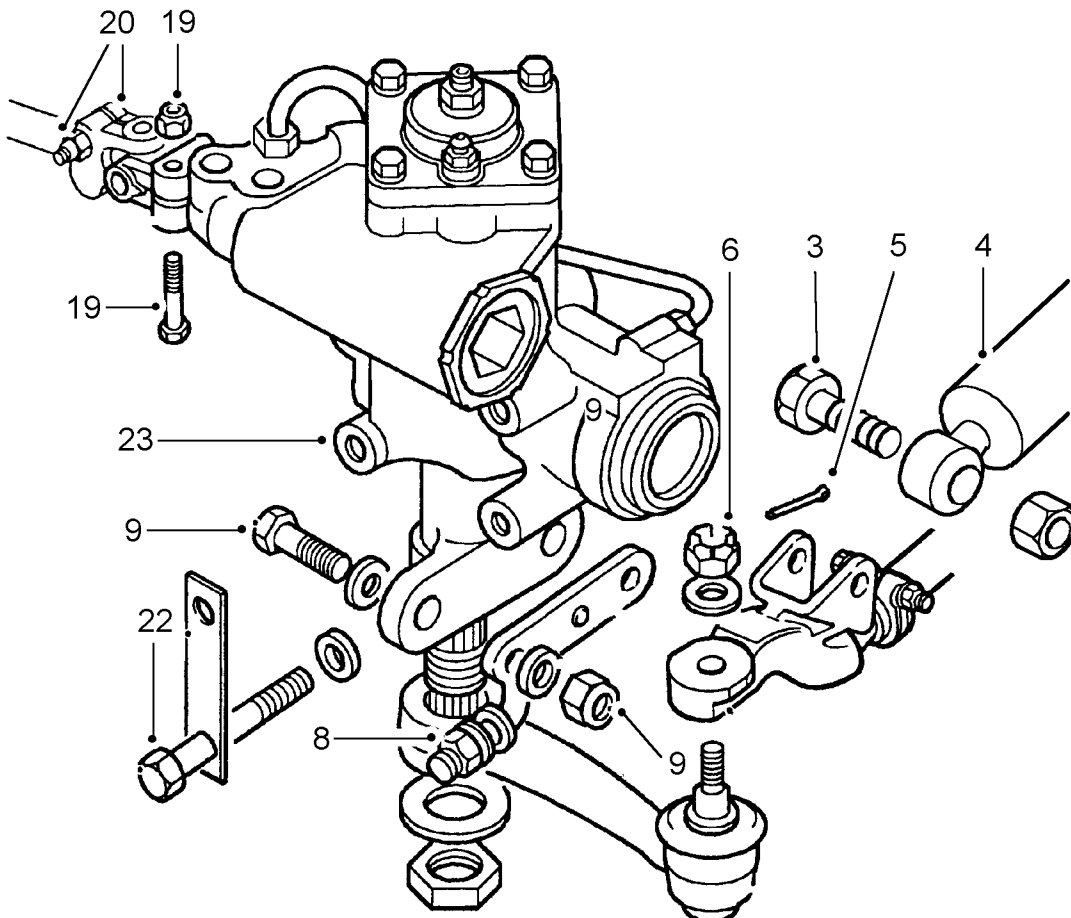

57M0613

7. Using tool **LRT-57-018** release drop arm from drag link.
8. Loosen, but do not remove, nut securing tie bar to mounting arm.
9. Remove 2 bolts securing tie bar to steering box.
10. Move tie bar aside.
11. Position container to collect any fluid spillage.
12. Lower vehicle.
13. Remove filler cap from power steering fluid reservoir.

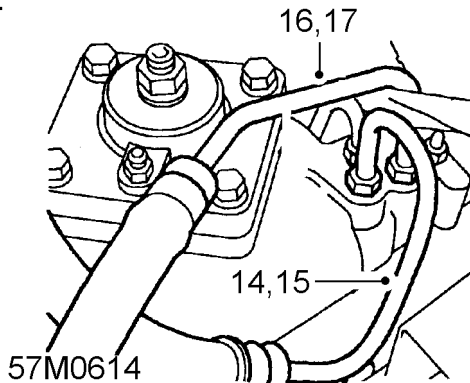

14. Loosen union securing feed pipe to steering box.
15. Disconnect feed pipe from steering box.
16. Loosen union securing return pipe to steering box.
17. Disconnect return pipe from steering box.



CAUTION: Plug the connections.

18. Centralise steering. *See Adjustment, power steering box - centralise*
19. Remove pinch bolt securing steering column universal joint to steering box.
20. Loosen pinch bolt securing universal joint to steering column.
21. Slide universal joint up steering column and release from steering box.
22. Remove 4 bolts securing steering box to chassis side member and collect 2 tab washers.
23. With assistance, lower steering box from vehicle and remove.

Refit

24. Clean mating faces of steering box and chassis side member.
25. With assistance, position steering box to vehicle, ensuring locating peg is engaged.
26. Fit bolts and tab washers securing steering box to chassis and tighten bolts to **80 Nm, 60 lbf ft.**
27. Connect steering column to steering box.
28. Tighten universal joint pinch bolts to **25 Nm, 19 lbf ft.**
29. Remove plugs from steering box and pipes.
30. Connect feed pipe to steering box and tighten union to **15 Nm, 11 lbf ft.**
31. Connect return pipe to steering box and tighten union to **20 Nm, 15 lbf ft.**
32. Fit fluid reservoir cap.
33. Raise vehicle on ramp.
34. Position tie bar to steering box and loosely fit bolts and washers.
35. Tighten nut securing tie bar to mounting arm to **80 Nm, 60 lbf ft** and then back-off one complete turn.
36. Tighten bolts securing tie bar to steering box to **81 Nm, 60 lbf ft** and then back-off one complete turn.
37. Fit drop arm to drag link and fit castellated nut.
38. Tighten castellated nut to **40 Nm, 30 lbf ft** and fit new split pin.
39. Connect steering damper to drag link.
40. Fit and tighten bolt securing damper.
41. Fit Panhard rod. *See FRONT SUSPENSION, Repair, panhard rod; Refit*
42. Lower vehicle.
43. Bleed power steering system. *See Adjustment, power steering system - bleed*
44. Test drive vehicle using both full locks to settle steering components. If possible, drive vehicle over uneven ground and include harsh braking.



WARNING: Do not test drive vehicle on public highway.

45. Drive vehicle in a straight line on level ground and stop.
46. Tighten nut securing tie bar to mounting to **110 Nm, 81 lbf ft.**
47. Tighten bolts securing tie bar to steering box to **81 Nm, 60 lbf ft.**
48. Ensure steering wheel is correctly aligned when wheels are positioned straight ahead.
49. Road test vehicle.



POWER STEERING FLUID RESERVOIR

Service repair no - 57.15.08

Remove

1. Position container to collect any fluid spillage.

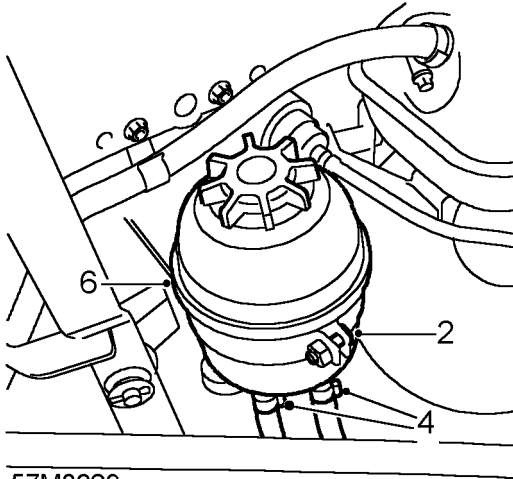

2. Loosen mounting bracket clamp bolt.
3. Raise reservoir from mounting bracket to gain access to hose clips.
4. Loosen 2 clips securing hoses to fluid reservoir.
5. Disconnect hoses from fluid reservoir.



CAUTION: Plug the connections.

6. Remove reservoir.



CAUTION: Discard fluid drained from system. Do not allow fluid to contact paint work. If spilled, remove fluid and clean area with warm water.

Refit

7. Position fluid reservoir and connect hoses.
8. Tighten clips securing hoses to fluid reservoir.
9. Fit reservoir to mounting bracket and tighten clamp bolt to **3 Nm, 2 lbf ft.**
10. Bleed power steering system. **See power steering system - bleed**
11. Remove container.

POWER STEERING PUMP

Service repair no - 57.20.14

Remove

1. Disconnect battery negative lead.
2. Remove drive belt. **See ELECTRICAL, Repair, Auxiliary drive belt**
3. Position container to collect any fluid spillage.

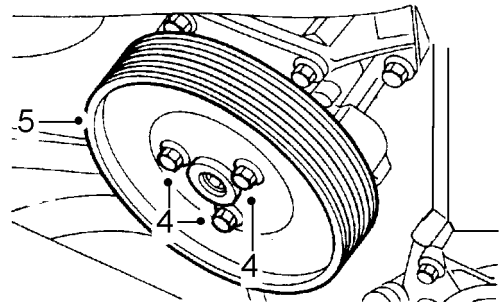

4. Using an Allen key to restrain PAS pump pulley, remove 3 bolts securing pulley to pump.
5. Remove PAS pump pulley.

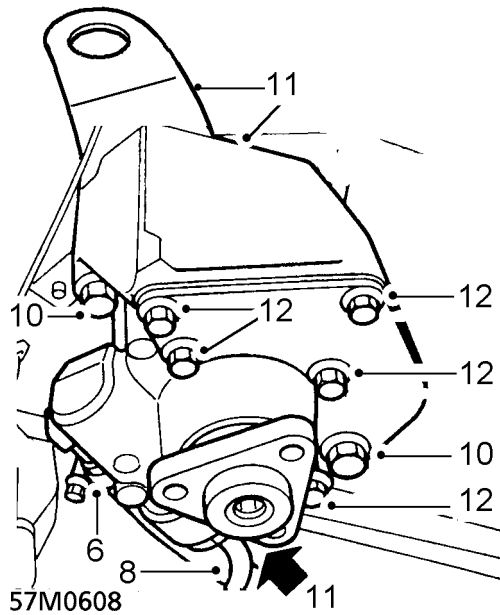

6. Loosen clip securing PAS hose to pump.
7. Disconnect hose from pump.
8. Loosen union securing PAS pipe to pump.
9. Disconnect PAS pipe from pump.

CAUTION: Plug the connections.



10. Remove 3 bolts securing PAS pump to engine.
11. Remove PAS pump and collect engine lifting bracket.

Do not carry out further dismantling if component is removed for access only.

12. Remove 5 bolts securing clamping bracket to pump.
13. Remove clamping bracket from pump and fit to new pump.
14. Tighten bolts securing clamping bracket to pump to **9 Nm, 7 lbf ft.**

Refit

15. Clean mating faces of PAS pump and engine.
16. Fit PAS pump and engine lifting bracket to engine.
17. Fit and tighten bolts securing PAS pump to engine to **35 Nm, 26 lbf ft.**
18. Remove plugs.
19. Connect PAS pipe to pump and tighten union to **20 Nm, 15 lbf ft.**
20. Connect PAS hose to pump and secure with clip.
21. Position pulley to PAS pump.
22. Coat threads of PAS pump pulley bolts with Loctite 242.
23. Restrain pulley using Allen key and tighten bolts to **10 Nm, 7 lbf ft.**
24. Fit drive belt. **See ELECTRICAL, Repair, Auxiliary drive belt**
25. Reconnect battery negative lead.
26. Bleed power steering system. **See Adjustment, power steering system - bleed**
27. Remove container.



STEERING COLUMN

Service repair no - 57.40.01

Remove

1. Loosen clip securing air inlet hose to MAF sensor.
2. Loosen clip securing air inlet hose to plenum chamber.
3. Remove air inlet hose.

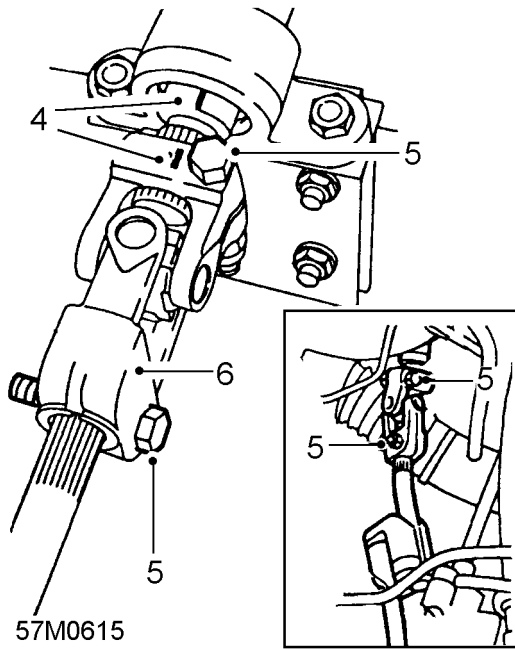

57M0615

4. Mark relationship of top universal joint to steering column and shaft.
5. Remove 2 bolts from top universal joint.
6. Remove steering shaft top universal joint.
7. Remove centre pad from steering wheel.
8. Remove nut securing steering wheel to column and collect washer.
9. Using tools **LRT-57-014** and **LRT-57-015**, remove steering wheel from column.
10. Disconnect battery negative lead.
11. Remove instrument panel. **See INSTRUMENTS, Repair, instrument panel**

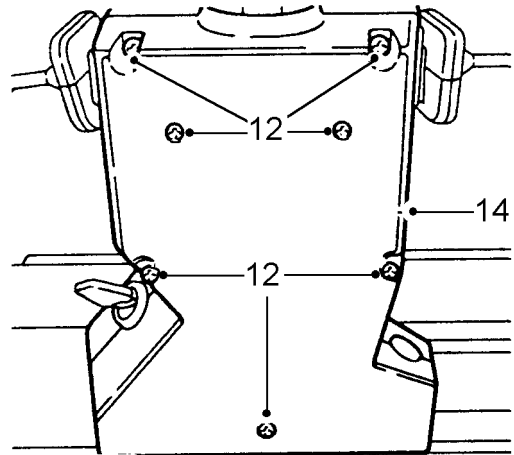

57M0616

12. Remove 7 screws securing nacelle to steering column.
13. Remove top half of nacelle.
14. Release bottom half of nacelle from indicator and light stalk grommets and remove.

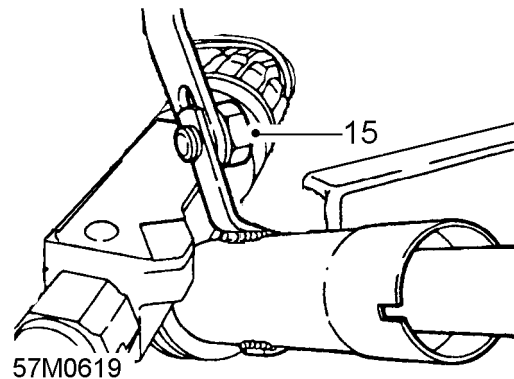

57M0619

15. Remove bolt securing steering column to upper mounting bracket.

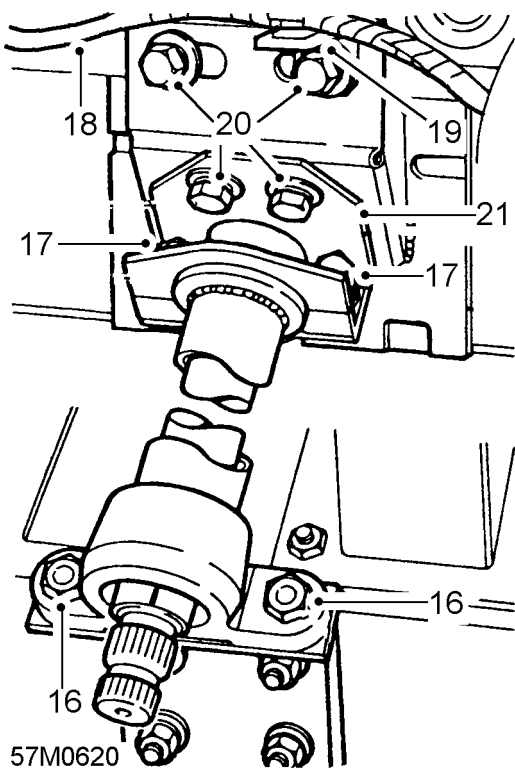

16. Remove 2 lower bolts securing steering column to body.
17. Remove 2 upper clamping bolts and collect clamp and rubber.
18. Release harness from clip on column upper mounting bracket.
19. Release clip from column upper mounting bracket.
20. Remove 4 bolts securing column upper mounting bracket.
21. Remove upper mounting bracket.
22. Disconnect 3 multiplugs from rear of switch pack.
23. Loosen screw and remove switch pack.
24. Disconnect multiplug and 6 Lucars from ignition switch.

 **NOTE: Note the positions of the Lucar connections to the ignition switch.**

25. Drill out 2 shear bolts securing ignition barrel to steering column.
26. Remove ignition barrel and collect washers.
27. Remove brake pedal. **See BRAKES, Repair, brake pedal**
28. Remove steering column and upper mounting bracket from vehicle.

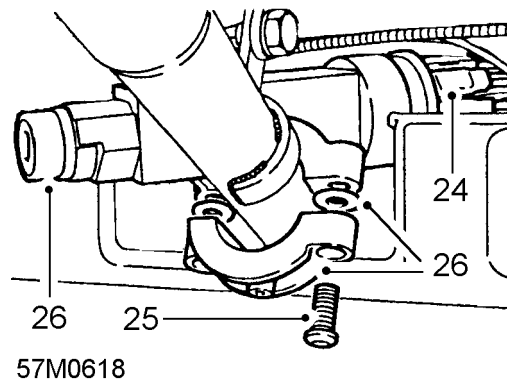
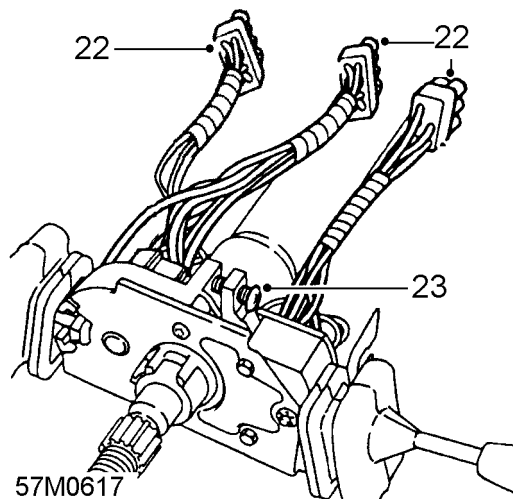

 **NOTE: The steering column is a non serviceable component and can only be replaced as a complete assembly.**

Refit

29. Manoeuvre steering column into position in vehicle.
30. Fit brake pedal. **See BRAKES, Repair, brake pedal**
31. Position ignition barrel to steering column and rotate inner shaft to line up slot with barrel plunger.
32. Position barrel clamp to steering column and secure with shear bolts. Evenly tighten bolts, but do not shear them.
33. Temporarily fit steering wheel and operate switch and lock mechanism several times to ensure it functions correctly.



34. Fully tighten ignition barrel bolts until heads shear.
35. Connect multiplug and Lucars to ignition barrel.
36. Fit switch pack to steering column and secure with screw.
37. Connect multiplugs to rear of switch pack.
38. Position column upper mounting bracket and tighten bolts to **22 Nm, 16 lbf ft.**
39. Fit clip to mounting bracket and secure harness.
40. Fit rubber and clamp to upper steering column.
41. Fit clamp bolts and tighten to **22 Nm, 16 lbf ft.**
42. Fit lower steering column bolts and tighten to **22 Nm, 16 lbf ft.**
43. Fit bolt securing column to upper mounting bracket and tighten to **22 Nm, 16 lbf ft.**
44. Fit lower half of steering column nacelle and secure to stalk grommets.
45. Fit top half of steering column nacelle.
46. Fit and tighten screws securing nacelle to steering column.
47. Fit instrument panel. **See INSTRUMENTS, Repair, instrument panel**
48. Reconnect battery negative lead.
49. Turn indicator cancelling ring so that slots are vertical and lug with arrow points to the left.
50. Fit steering wheel with finisher attachment lug at bottom, ensuring indicator cancelling forks locate in ring slots.
51. Fit new washer and tighten securing nut to **50 Nm, 37 lbf ft.**
52. Fit centre pad to steering wheel.
53. With steering lock engaged, and wheels in straight ahead position, align assembly marks and connect steering shaft universal joint to steering column.
54. Tighten universal joint pinch bolts to **25 Nm, 18 lbf ft.**
55. Fit air inlet hose between plenum chamber and MAF sensor and tighten clips.

STEERING LOWER SHAFT

Service repair no - 57.40.25

Remove

1. Set road wheels and steering wheel in straight ahead position.
2. Loosen clip securing air inlet hose to MAF sensor.
3. Loosen clip securing air inlet hose to Plenum chamber.
4. Remove air inlet hose.

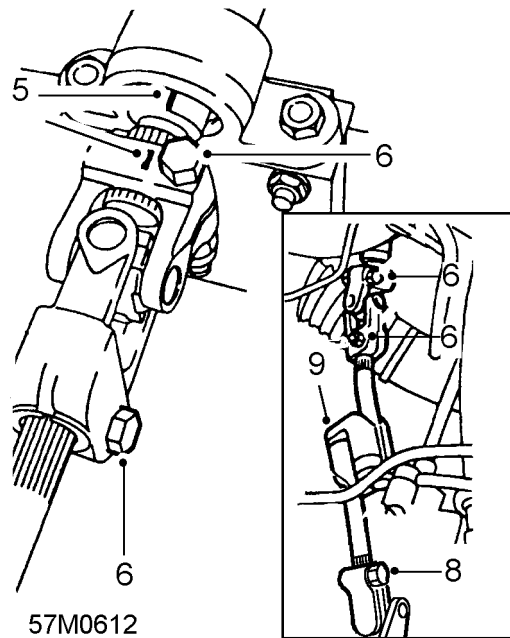

5. Mark relationship of steering column inner shaft to top universal joint.
6. Remove 2 bolts from top universal joint.
7. Remove lower bolt from bottom universal joint.
8. Loosen upper bolt from bottom universal joint.
9. Remove steering shaft and collect universal joints.
10. Inspect universal joints for wear and excessive play. Renew if necessary.
11. Inspect universal joints for stiffness. Lubricate if necessary.

Refit

12. Fit universal joints to steering shaft so pinch bolts line up with flats on shaft.
13. Fit steering shaft assembly to steering column and steering box.
14. Align bolt holes with grooves in splines. Fit pinch bolts and tighten to **25 Nm, 18 lbf ft.**
15. Fit air inlet hose between plenum chamber and MAF sensor.
16. Tighten clips securing hose to plenum chamber and MAF sensor.

DROP ARM

Service repair no - 57.50.14

Remove

1. Raise vehicle on a ramp [hoist].

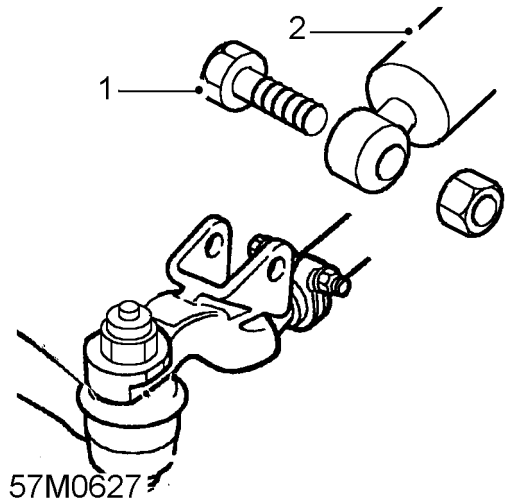

2. Remove bolt securing steering damper to drag link.
3. Disconnect steering damper from drag link.

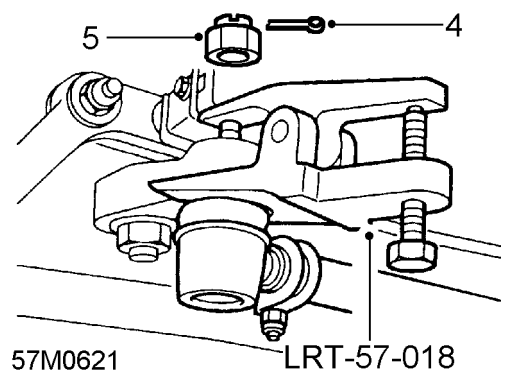

4. Remove split pin from castellated nut securing drag link to drop arm.
5. Remove castellated nut securing drag link to drop arm.
6. Using special tool **LRT-57-018**, disconnect drag link from drop arm.

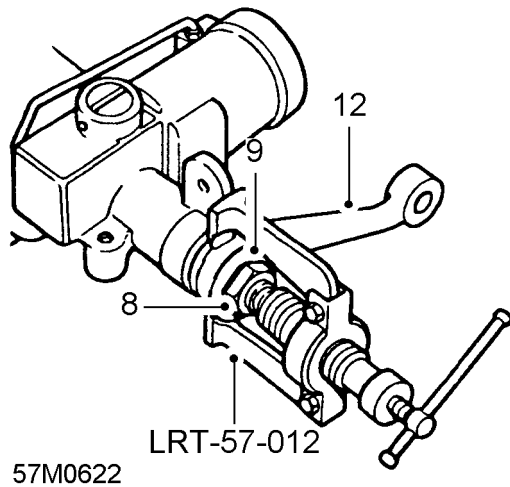

7. Mark relationship between drop arm and steering box for reassembly.
8. Bend back tabs on drop arm locking washer.
9. Loosen nut securing drop arm to steering box but do not remove.
10. Use special tool **LRT-57-012** to release drop arm from steering box spline.
11. Remove nut and discard locking washer.
12. Remove drop arm.

Refit

13. Centralise steering box. **See Adjustment, power steering box - centralise**
14. Align reassembly marks and fit drop arm onto steering box splines.
15. Fit new locking washer and retaining nut to secure drop arm to steering box. Tighten nut to **175 Nm, 130 lbf ft.**
16. Bend over locking washer.
17. Fit drag link to drop arm and tighten castellated nut to **40 Nm, 30 lbf ft.**
18. Fit new split pin to castellated nut.
19. Fit steering damper to drag link.
20. Fit and tighten bolt securing steering damper to drag link.
21. Lower vehicle.

TRACK ROD

Service repair no - 57.55.09

Remove

1. Raise vehicle on a ramp [hoist].
2. Centralise steering. **See Adjustment, power steering box - centralise**

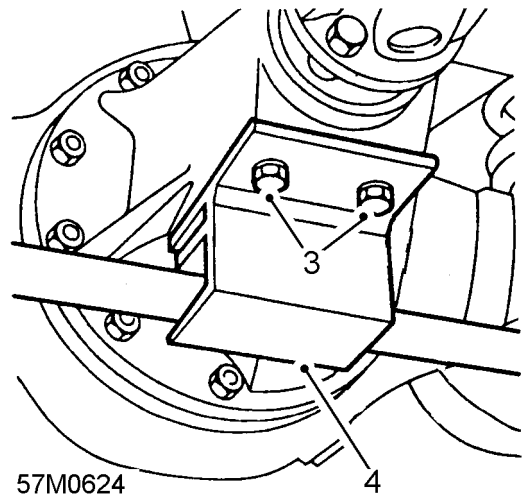

3. Remove 2 bolts securing track rod protection bracket to differential housing.
4. Remove track rod protection bracket.

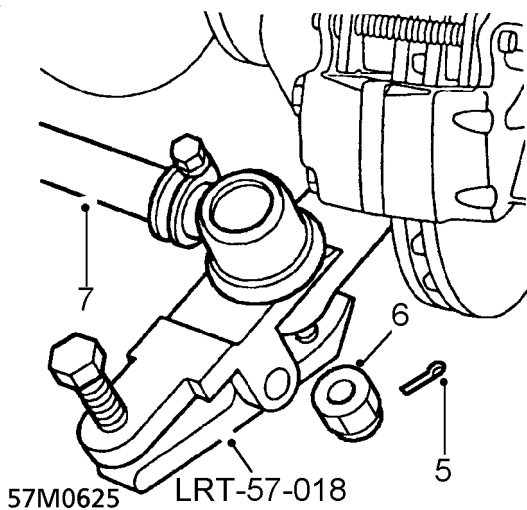

5. Remove 2 split pins from castellated nuts securing track rod to swivel hubs.
6. Remove 2 castellated nuts securing track rod to swivel hubs.
7. Using special tool **LRT-57-018**, release track rod ball joints from swivel hubs.
8. Remove track rod.

Do not carry out further dismantling if component is removed for access only.

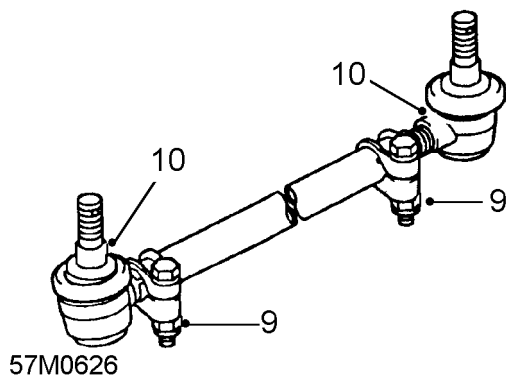

9. Loosen 2 clamp bolts securing linkages to track rod.
10. Remove linkages.
11. Fit new linkages to track rod and loosely tighten clamp bolts.
12. Screw in linkages to full extent of threads and fully tighten clamp bolts.

Refit



CAUTION: A track rod that is damaged or bent must be renewed. DO NOT attempt to repair or straighten it.

13. Fit track rod and connect to swivel hubs.
14. Fit and tighten castellated nuts to **40 Nm, 30 lbf ft.**
15. Fit new split pins to castellated nuts.
16. Fit track rod protection bracket to differential housing and tighten bolts.
17. Check wheel alignment. **See Adjustment, front wheel alignment**
18. Lower vehicle.



STEERING DAMPER

Service repair no - 57.55.21

Remove

1. Raise vehicle on a ramp [hoist].

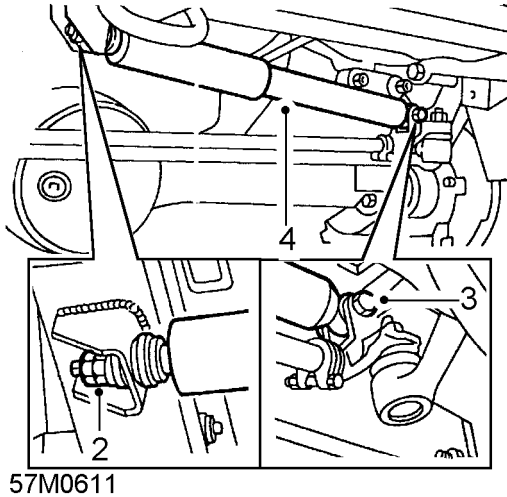

2. Remove 2 nuts securing steering damper to chassis member and collect washer.
3. Remove nut and bolt securing steering damper to drag link.
4. Release steering damper from drag link and chassis member and remove.

Refit

5. Position damper to chassis member and drag link.
6. Fit bolt and new nut securing damper to drag link and tighten.
7. Fit washer and nuts securing steering damper to chassis and tighten.
8. Lower vehicle.

DRAG LINK AND DRAG LINK ENDS

Service repair no - 57.55.17

Remove

1. Park vehicle on level ground and chock rear wheels.
2. Set road wheels in straight ahead position.
3. Raise vehicle and fit axle stands or use a ramp.
4. Remove front road wheel.
5. Disconnect steering damper at drag link bracket.

6. Remove split pin and castellated nut securing drag link ball joints to swivel housing arms.
7. Disconnect drag link ball joints using **LRT-57-018**.
8. Remove drag link.

Remove drag link ends

9. Slacken clamp bolts.
10. Unscrew ball joints and remove from drag link.
11. Clean internal threads of drag link.

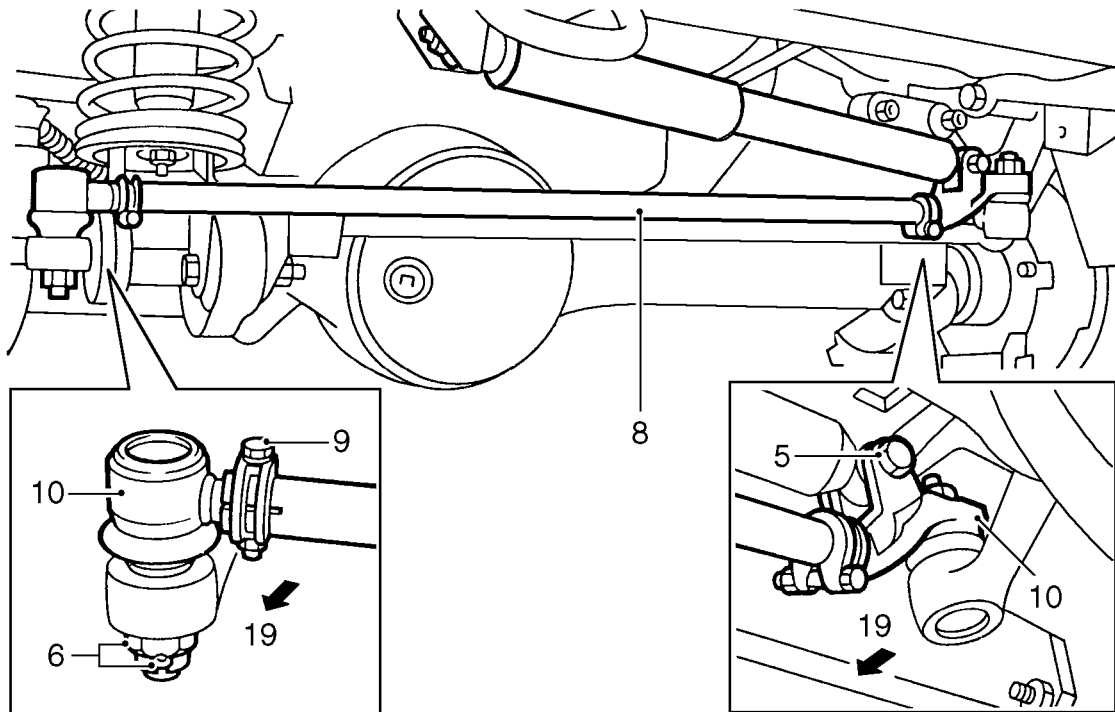

J6319

Refit drag link ends

12. Fit new ends to drag link and loosely fit clamp bolts.
13. Set ball joints to drag link measurement to 28,5 mm.
14. Adjust ball pin centres to nominal length of 924 mm, this length is adjusted during refit.

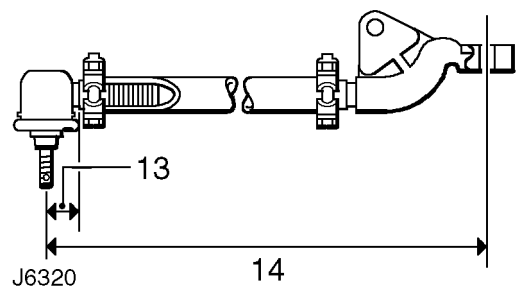

J6320



15. Centralise steering box **See Adjustment, Centralise steering box .**
16. Align steering wheel, if necessary.

Refit drag link



CAUTION: A drag link that is damaged or bent must be renewed. DO NOT attempt to repair it.

17. Fit drag link to swivel housing arms and tighten nuts to **40 Nm (30 lbf/ft)**. Fit new split pins.
18. Ensure full steering travel is obtained between lock stops **See Adjustment, Steering lock stops**. Adjust drag link length to suit.
19. Tap ball joints in direction shown so both pins are in same angular plane.
20. Tighten clamp bolts to **14 Nm, 10 lbf/ft**.
21. Refit road wheel and remove axle stands or vehicle from ramp.
22. Road test vehicle.
23. If driving straight ahead and steering wheel is offset by $0^\circ \pm 5^\circ$ in either direction, correct by adjusting drag link length.



WARNING: To correct steering wheel deviations greater than $\pm 5^\circ$ remove and reposition steering wheel See Steering wheel.



POWER STEERING BOX

Service repair no - 57.10.07



WARNING: Wear safety glasses while removing and refitting circlips and retaining ring.



CAUTION: Absolute cleanliness is essential when overhauling the power steering box.

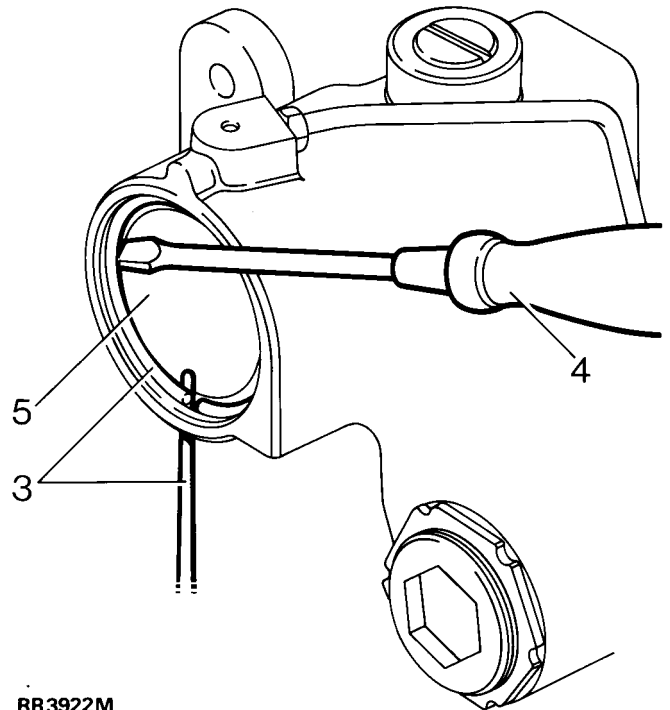
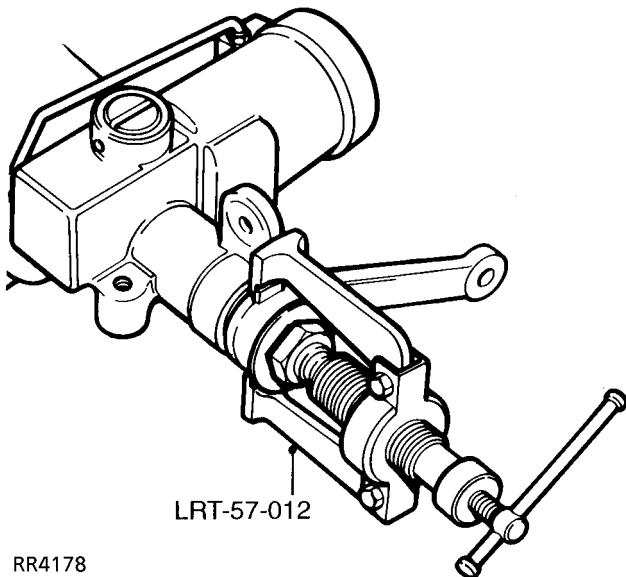

RR3922M

3. Rotate retainer ring until one end is 12 mm from extractor hole. Using a drift through hole in cylinder, lift retaining ring from groove in cylinder bore.
4. Remove retainer ring, using a screwdriver.
5. Turn input shaft left lock on LH drive, right lock on RH drive, until piston pushes out cover. Turn input shaft fully in opposite direction, applying pressure to piston.

1. Remove steering box from vehicle. **See Repair, Power Steering Box** . Mark drop arm and steering box for realignment on assembly. Remove drop arm using extractor **LRT-57-012**. Loosen drop arm securing nut, but do not remove before using extractor. Remove dirt excluder from output shaft.
2. Drain oil, remove blanking plugs and bleed screw. Hold steering box over drain tin, turn input shaft from lock to lock, until oil is drained. Refit bleed screw.

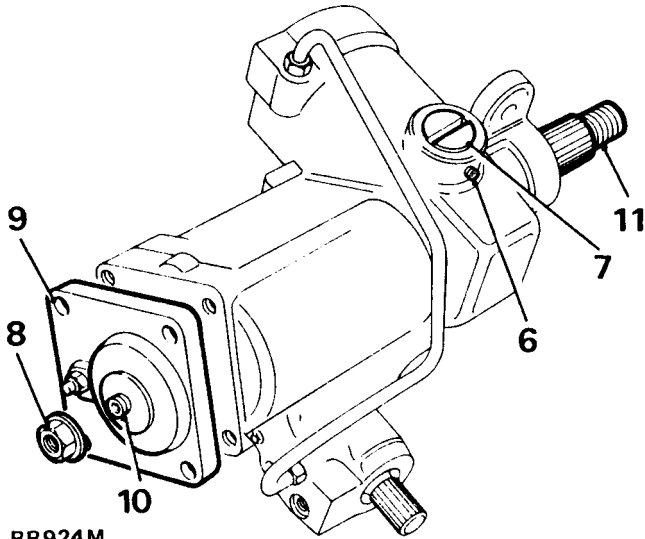

RR924M

6. Remove set screw retaining rack pad adjuster.
7. Remove rack adjuster and pad.
8. Remove sector shaft adjuster locknut.
9. Remove four bolts from sector shaft cover.
10. Screw in sector shaft adjuster until cover is removed.



NOTE: Sealant is applied to hexagon socket to 'tamperproof' sector shaft adjuster.

11. Slide out sector shaft.

12. Remove piston, a bolt screwed into piston will assist removal.
13. Remove input shaft dirt excluder.

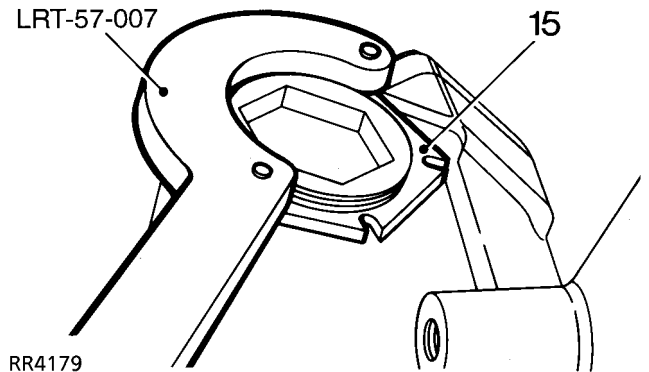

RR4179

14. Remove worm adjuster locknut using 'C' wrench **LRT-57-007**.
15. Remove worm adjuster using wrench **LRT-57-006**.

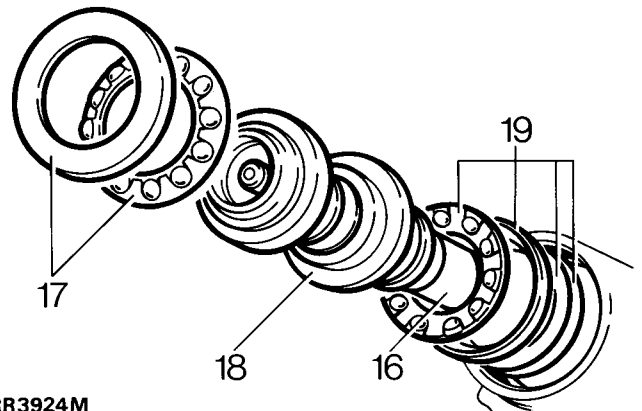

RR3924M

16. Tap splined end of shaft to free bearing.
17. Remove bearing cup and caged ball bearing assembly.
18. Remove valve and worm assembly.
19. Remove inner bearing cage, cup and shim washers. Retain shims for reassembly.



NOTE: Should difficulty be experienced, warm casing and bearing assembly. Cool bearing cup using a mandrel and tap steering box on a bench.



Steering box seals

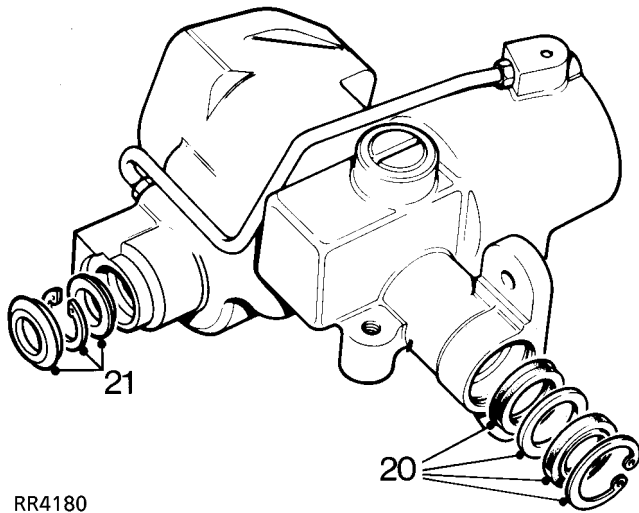

RR4180

20. Remove circlip and seal from sector shaft housing bore.

CAUTION: Do not remove sector shaft bearings from casing. Replacement parts are not available. If sector shaft bearings are worn, fit a new steering box.

21. Remove dirt excluder, circlip and seal from input shaft housing bore.

CAUTION: The use of a seal puller is recommended to prevent damage to casing, and possible oil leaks.

INSPECTING

Piston

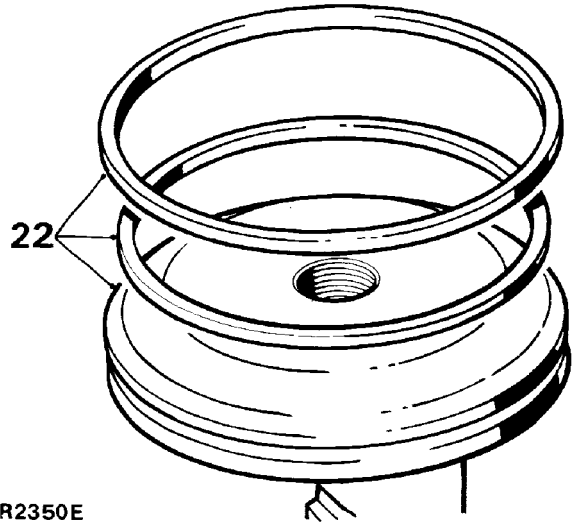

RR2350E

22. Discard all rubber seals and provide replacements.

NOTE: A rubber seal is fitted behind plastic ring on rack piston. Discard seal and plastic ring.

Steering box casing

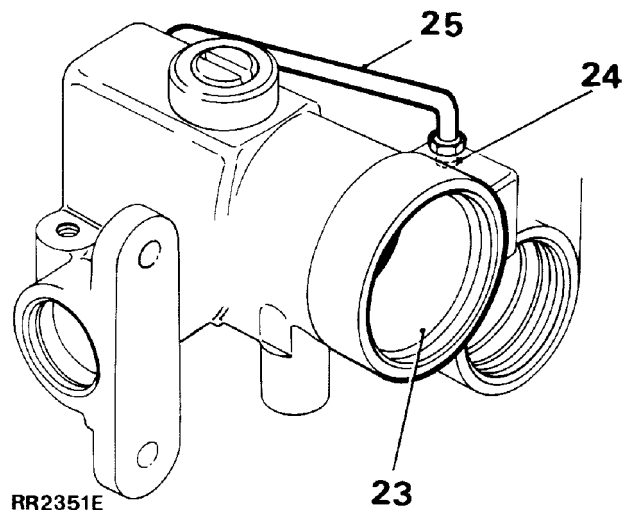

RR2351E

23. Examine piston bore for scoring and wear.

24. Examine feed tube.

25. Fit a new feed tube if damaged. Tighten union to **20 Nm, 15 lbf ft.**

Sector shaft assembly

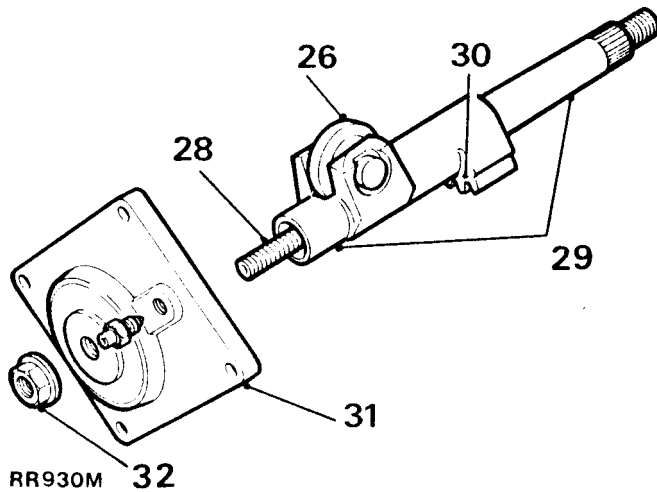

- 26. Check there is no side play on roller.
- 27. If side play on roller exists fit a new sector shaft.
- 28. Check condition of adjuster screw threads. Check adjuster end float. Fit new adjuster if end float exceeds 0.15 mm, 0.006 in.
- 29. Examine bearing areas on shaft for excessive wear.
- 30. Examine gear teeth for uneven or excessive wear.

Sector shaft cover assembly

- 31. Inspect cover and bearing. If worn or damaged, fit a new steering box.

Sector shaft adjuster locknut

- 32. The locknut is also a fluid seal. Fit new nut at overhaul.

Valve and worm assembly

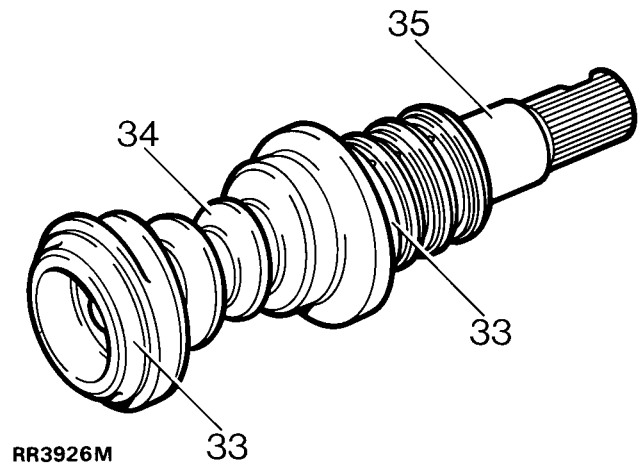

- 33. Examine bearing areas for wear. The areas must be smooth and not indented.
- 34. Examine worm track which must be smooth and not indented.
- 35. Check for wear on torsion bar assembly pin. No free movement should exist between input shaft and torsion bar or between torsion bar and worm.



NOTE: Any sign of wear makes it essential to fit new valve and worm assembly.

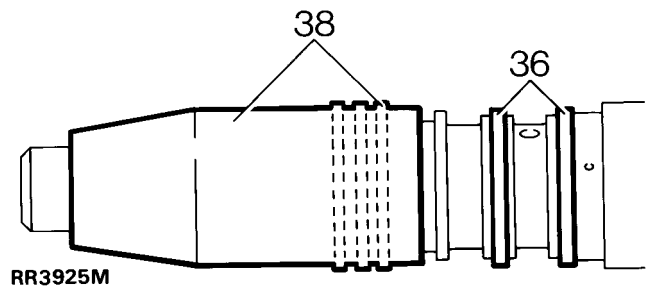

- 36. Examine valve rings for cuts, scratches and grooves. The valve rings should be free to rotate in grooves.



- 37. If required, replace all three rings, using ring expander **LRT-57-019**. The expander will not pass over rings already fitted. Remove rings to allow access without damaging seal grooves.
- 38. Warm rings and expander tool to aid assembly. Fit rings to expander, slide expander over valve and worm assembly. In turn fit rings to their grooves. Remove expander, slide valve and worm assembly into ring compressor **LRT-57-020** and allow to cool.

Ball bearing and cage assemblies

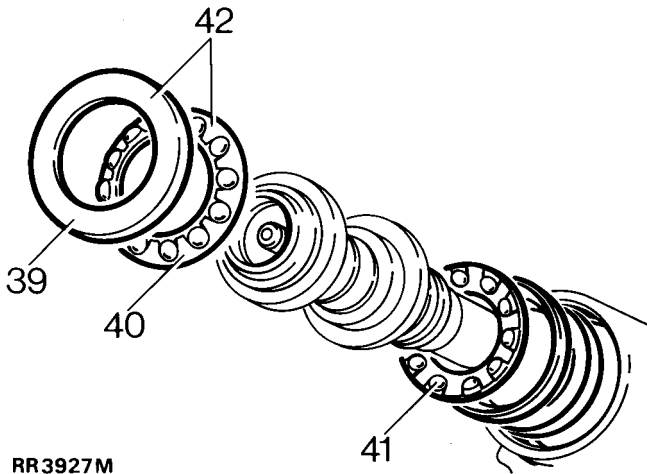

RR3927M

- 39. Examine ball races and cups for wear and general condition.
- 40. If ball cage has worn against bearing cup, fit replacements.
- 41. Bearing balls must be retained by cage.
- 42. Bearing and cage repair is carried out by complete replacement of assembly.

Rack thrust pad and adjuster

- 43. Examine thrust pad for scores.
- 44. Examine adjuster for wear in pad seat.
- 45. Fit new sealing ring to rack adjuster.

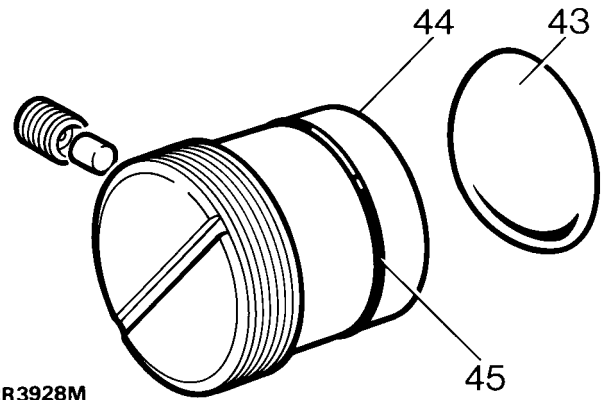

RR3928M

Rack and piston

- 46. Examine for excessive wear on rack teeth.
- 47. Ensure thrust pad bearing surface is free from scores and wear.
- 48. Ensure piston outer diameters are free from burrs and damage.

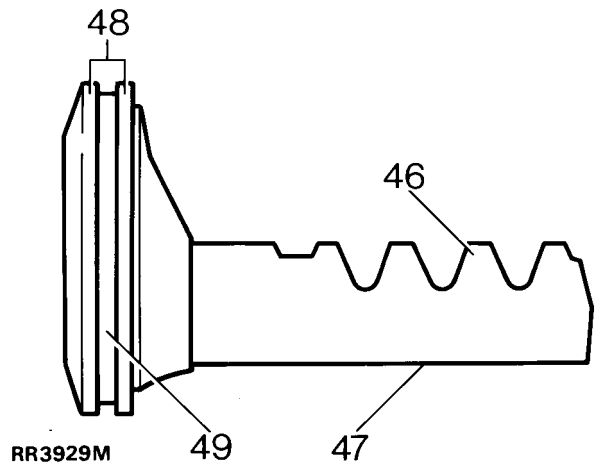

RR3929M

- 49. Examine seal and ring groove for scores and damage.
- 50. Fit new ring to piston. Warm nylon seal and fit to piston.
- 51. Slide piston assembly into cylinder with rack tube outwards.

Reassemble



NOTE: When fitting replacement oil seals lubricate with recommended fluid and ensure absolute cleanliness.

Sector shaft oil seal

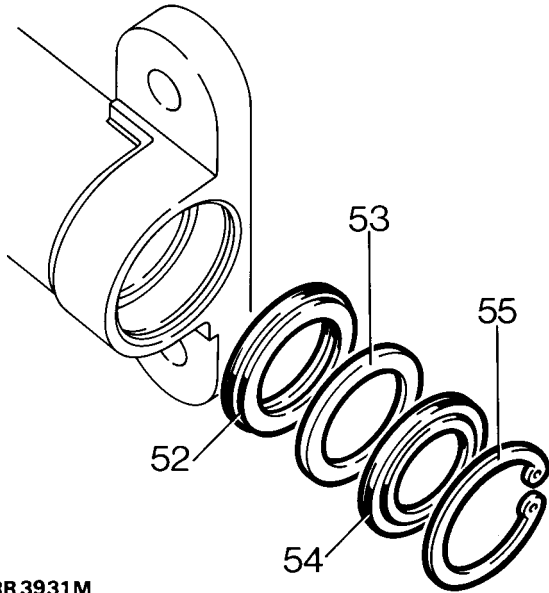

RR3931M

- 52. Fit oil seal, lip side first.
- 53. Fit extrusion washer.
- 54. Fit dust seal, lipped side last.
- 55. Fit circlip.

Fitting valve and worm assembly

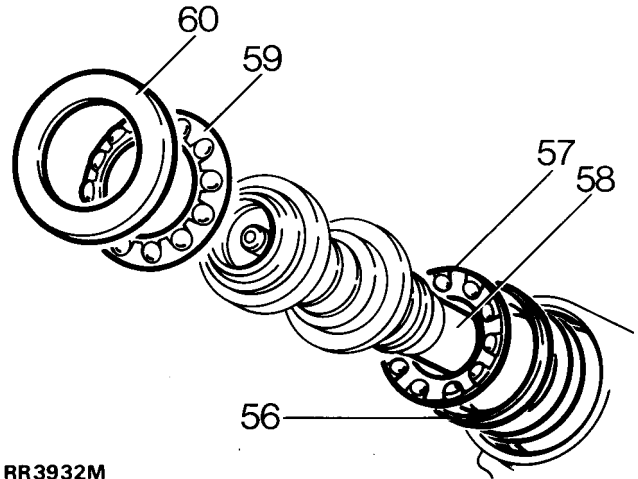

RR3932M

- 56. Refit original shims and inner bearing cup. Use Petroleum Jelly to aid assembly.



NOTE: If original shims are not used, fit shims of 0.76 mm, 0.030 in thickness.

- 57. Fit inner cage and bearings assembly.
- 58. Fit valve and worm assembly.
- 59. Fit outer cage and bearings assembly.
- 60. Fit outer bearing cup.
- 61. Fit new worm adjuster sealing ring.

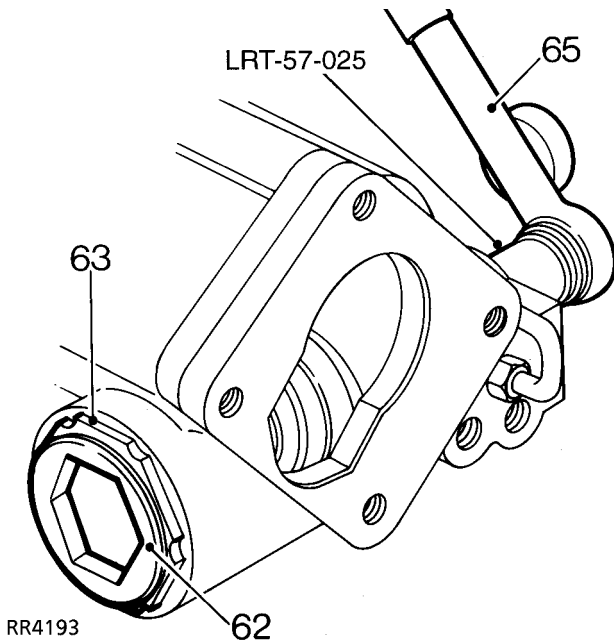

- 62. Loosely screw adjuster into casing.
- 63. Fit locknut, do not tighten.
- 64. Turn in worm adjuster until end float is almost eliminated. Ensure bearing cages are seated correctly.
- 65. Measure maximum rolling torque of valve and worm assembly, using a torque wrench and spline socket **LRT-57-025**.
- 66. Turn in worm adjuster while rotating shaft to increase figure measured in instruction 65. to 0.56 Nm, 0.41 lbf ft.
- 67. Back off worm adjuster 1/4 turn. Turn in worm adjuster to increase reading at 14 by 0.21 - 0.34 Nm, 0.15 - 0.25 lbf ft with locknut tight, **100 Nm 74 lbf ft**. Use worm adjusting wrench **LRT-57-006** and locknut wrench **LRT-57-028**.

Fitting rack and piston

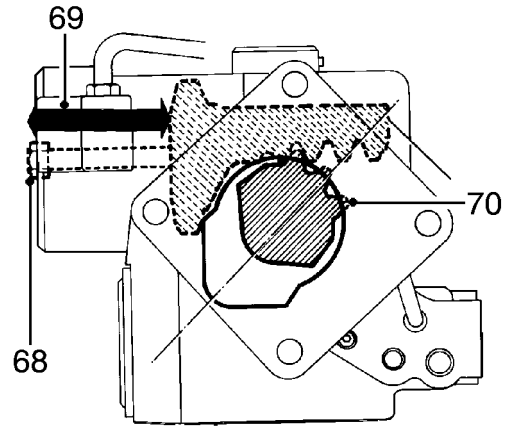

57M0660

- 68. Screw slave bolt into piston to aid assembly.
- 69. Fit piston and rack so piston is 70 mm, 2.75 in from outer end of bore.

Fitting sector shaft

- 70. Fit sector shaft using seal saver **LRT-57-021**. Align roller with cut out in casing. Push in sector shaft while rotating input shaft to allow sector roller to engage worm.

Fitting rack adjuster

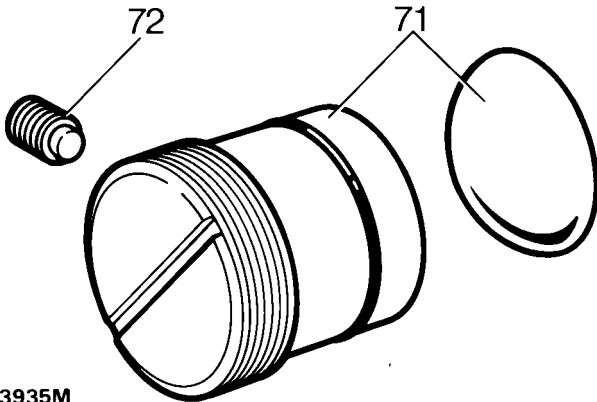

RR3935M

71. Fit rack adjuster and thrust pad to engage rack. Back off half turn on adjuster.
72. Loosely fit new nylon pad and adjuster set screw assembly.

Fitting sector shaft cover

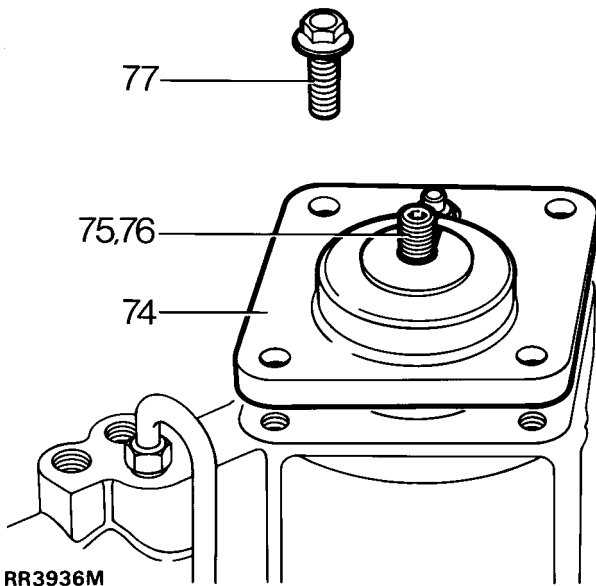

RR3936M

73. Fit new sealing ring to cover.
74. Align cover with casing.
75. Screw cover assembly fully on to sector shaft adjuster screw.

76. If necessary back off sector shaft adjuster screw. Tap cover in place to allow cover to joint fully with casing.



NOTE: Before tightening fixings, rotate input shaft to ensure sector shaft roller is free to move in valve worm. If initial resistance is left, turn adjuster screw approximately two turns in a clockwise direction.

77. Fit cover bolts. Tighten to **75 Nm, 55 lbf ft.**

Fitting cylinder cover

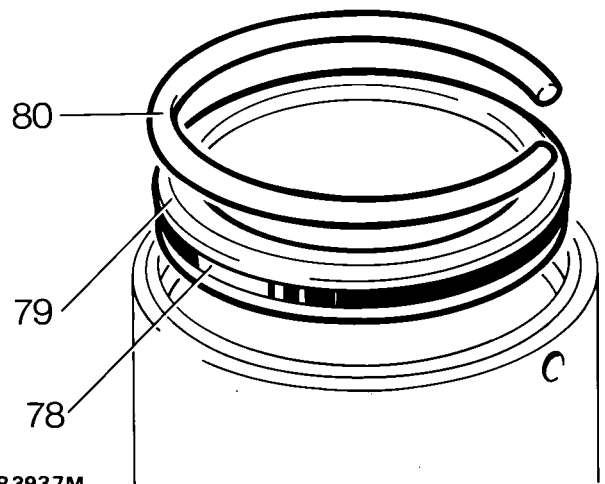

RR3937M

78. Fit new square section seal to cover.
79. Remove slave bolt fitted at instruction 68. Press cover into cylinder just to clear retainer ring groove.
80. Fit retaining ring to groove with one end of ring positioned 12 mm, 0.472 in from extractor hole.



Adjusting sector shaft



NOTE: Refit drop arm and tighten nut sufficiently to ensure that no backlash exists between drop arm and sector shaft.

- 81. To set worm on centre, rotate input shaft to full inner-lock full right lock for a left hand drive vehicle, full left lock for a right hand drive vehicle. Rotate input shaft back towards centre two full turns.

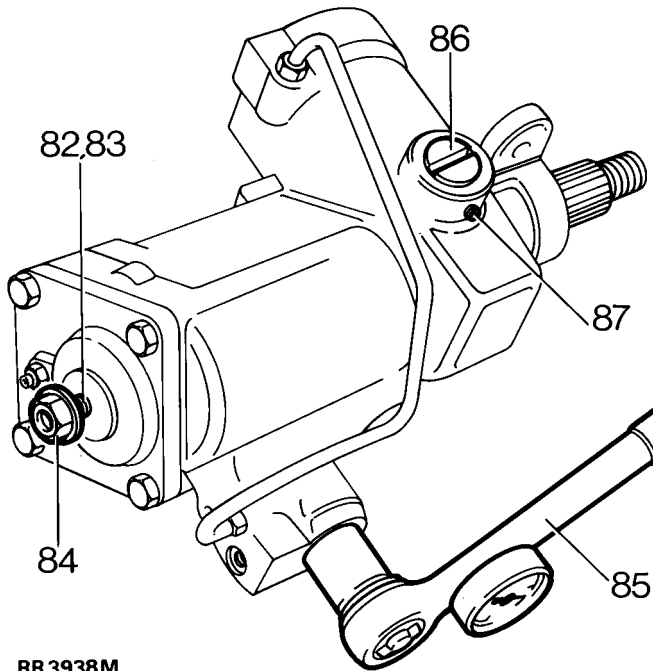

RR3938M

- 82. The box is now on centre and can be adjusted.
- 83. Hold input shaft and rock drop arm to establish backlash is present. Continue rocking and slowly turn sector shaft adjusting screw clockwise. Continue rotating adjuster screw until backlash has almost been eliminated.
- 84. Refit locknut and tighten.



NOTE: It is important steering box is centralised before any adjustments are made.

- 85. Check maximum rolling torque one and a quarter turns either side of centre position, using a torque wrench and spline socket **LRT-57-025**. Rotate adjuster screw to obtain across centre torque of 0.34 Nm, 0.25 lbf ft plus torque figure at one and a quarter turns. Tighten adjuster locknut to **60 Nm, 44 lbf ft**.

Adjusting rack adjuster.

- 86. Turn in rack adjuster to increase figure measured in instruction 34. by 0.23 - 0.34 Nm, 0.17 - 0.25 lbf ft.
The final figure may be less, but must not exceed 1.35 Nm, 1.0 lbf ft.
- 87. Lock rack adjuster in position with grub screw. Tighten to **5 Nm, 4 lbf ft**.

Torque peak check

With input shaft rotated from lock to lock, rolling torque figures should be greatest across centre position and equally disposed about centre position.

The condition depends on value of shimming fitted between valve and worm assembly inner bearing cup and casing. The original shim washer value will give correct torque peak position unless major components have been replaced.

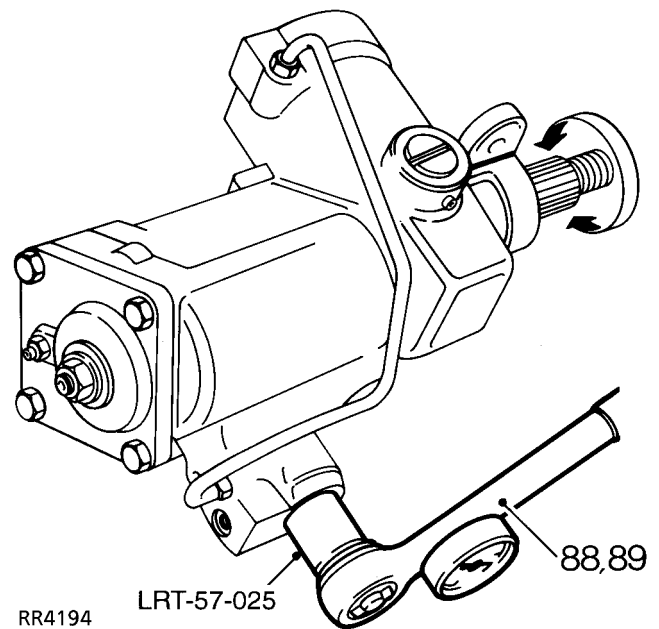

RR4194

- 88. With input coupling shaft toward the operator, turn shaft fully counter-clockwise.
- 89. Check torque figures obtained from lock to lock using torque wrench and spline socket **LRT-57-025**.
- 90. Check also for equal engagement either side of centre.

Adjustments

91. Note where greatest figures are recorded relative to steering position. If greatest figures are not recorded across centre of travel (steering straight-ahead), adjust as follows:

If torque peak occurs **before** centre position, **add** to shim washer value; if torque peak occurs **after** centre position, **subtract** from shim washer value, **refer to fitting valve and worm assembly** .

Shim washers are available as follows:
0.03mm, 0.07mm, 0.12mm and 0.24mm
0.001in, 0.003in, 0.004in and 0.008in.



NOTE: Adjustment of 0.07mm, 0.003 in to shim value will move torque peak area by 1/4 turn on the shaft.



CAUTION: When reshimming valve and worm, extreme caution must be exercised to prevent seal damage during reassembly.

Input shaft oil seal

92. Fit seal, lip side first, into housing. Use seal saver **LRT-57-016** and seal installer **LRT-57-026**. Note that seal is fitted to a depth of 4.75 - 5.00 mm, 0.19 - 0.20 in from face of box.
93. Secure seal with circlip.
94. Smear inner lip of dirt excluder with grease. Fit dirt excluder using **LRT-57-027**. When fitted correctly outer shoulder of excluder is 4.00 - 4.50 mm, 0.16 - 0.18 in from face of box, dimension 'X'.
95. Remove drop arm. Smear inner lip of dirt excluder with PTFE grease and refit, ensuring outer lip is flush with casing.
96. With input shaft on centre, align assembly marks on drop arm and steering box. Fit drop arm to steering box using a new tab washer. Tighten nut to **175 Nm, 130 lbf ft**, bend over tab.
97. Fit steering box **See Repair, Power Steering Box** .

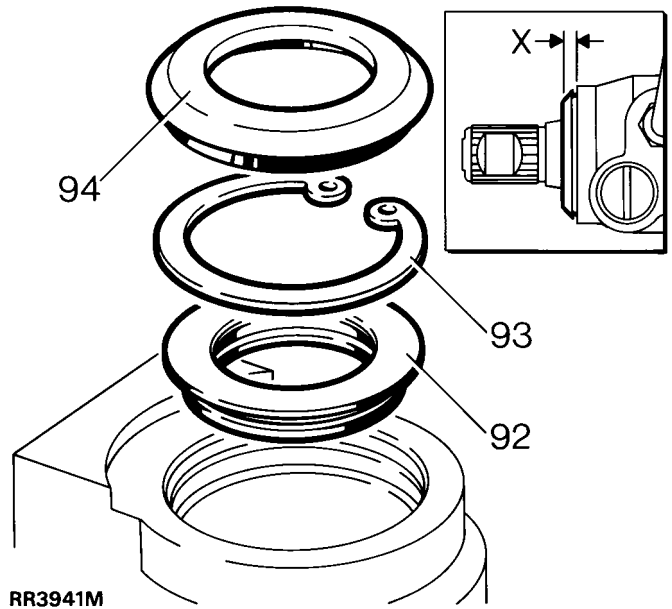



TORQUE VALUES

	Nm	lbf ft
Drag link to drop arm	40	30
Ball joint nuts	40	30
Clamp bolt nuts	14	10
Steering column bracket nuts	22	16
Steering wheel nut	50	37
Tie bar to mounting nut	110	80
Universal joint pinch bolt	25	18
PAS box adjuster locknut	60	45
Drop arm nut	175	130
Sector shaft cover to steering box	75	55
Steering box to chassis	80	60
Steering box fluid pipes 14mm thread	15	11
Steering box fluid pipes 16mm thread	20	15
Tie bar	80	60
Adjuster grub screw	5	4
PAS high pressure fluid pipe	20	15
Power steering pump mounting	35	25
Pulley bolts, power steering pump	10	7
Hose clamp	3	2
Front clamping bracket bolts	9	7 PAS reservoir
Hose clamp	3	2

The following Torque values are for screws and bolts that are not specified on previous page.

METRIC	Nm	lbf ft
M5	6	4.5
M6	9	7
M8	25	18
M10	45	33
M12	90	65
M14	105	77
M16	180	133
UNC / UNF	9	7
5/16	24	18
3/8	39	29
7/16	78	58
1/2	90	65
5/8	135	100



DESCRIPTION

The front suspension design allows maximum wheel travel and axle articulation providing good ground clearance without loss of traction or directional stability. A wheel speed sensor is attached to each swivel housing with a reluctor ring on the constant velocity joints. The input from the wheel sensors are used by the engine management ECM for 'Off-road detection'.

Long radius arms are fitted to the front axle and provide maximum axle articulation which is vital for off road performance. The radius arms are secured to fabricated mounting brackets welded to the front axle. Flexible rubber bushes are used on a stem end joint to secure the rear of the radius arms to mountings on the chassis cross member.

A panhard rod, which ensures that the front axle remains centrally located, is fitted transversely and

also uses ferrule rubber bush mountings at both axle and chassis locations.

Two rubber bearing bushes, with retaining straps, secure the rear of the anti-roll bar to the chassis mountings, while bushed links support the front of the bar to the front axle.

Conventional long travel coil springs and hydraulic shock absorbers are used to control body movement in all conditions. The shock absorbers are secured to fabricated towers which are bolted to the chassis. The upper and lower fixings use a single location stud with flexible rubber bushes, support washers and securing nuts. Retaining plates are used to secure the coil springs to the fabricated towers and axle mountings.

Rubber bump stops are fitted underneath the chassis, adjacent to the front road springs, and prevent possible damage that could occur should there be excessive axle to chassis movement.

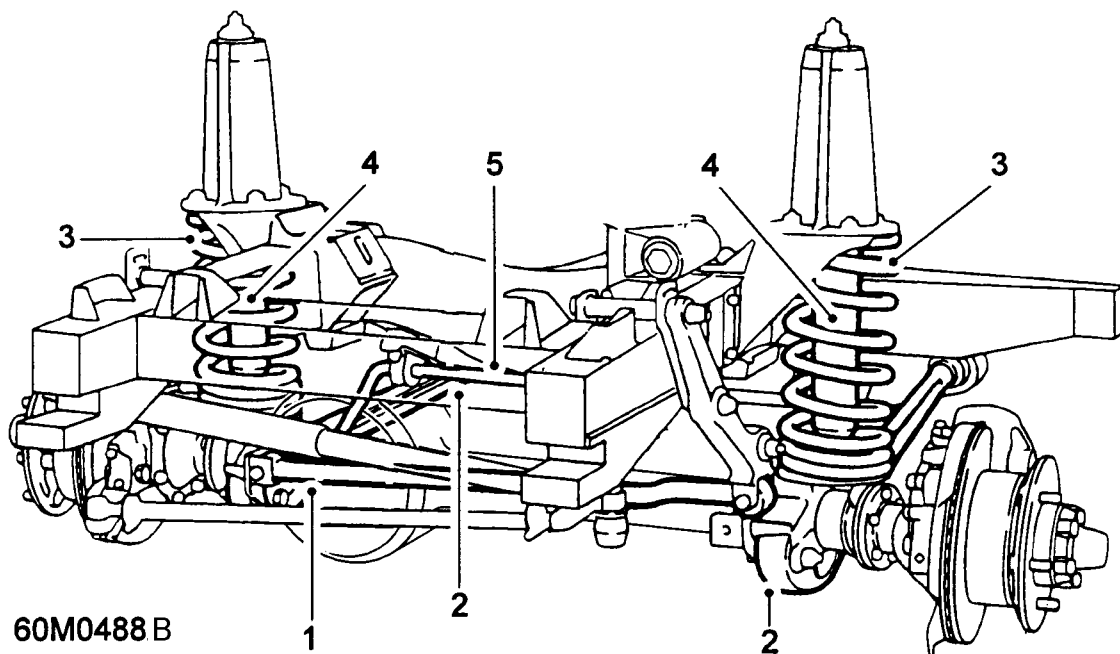

Front suspension

- | | |
|-----------------|-------------------------|
| 1. Panhard rod | 4. Shock absorber |
| 2. Radius arms | 5. Anti-roll [sway] bar |
| 3. Coil springs | |

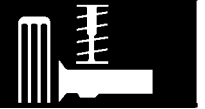

SELF LOCKING NUTS



WARNING: Where self locking nuts are removed, they must be replaced with new nuts of same specification.

ANTI-ROLL [SWAY] BAR

Service repair no - 60.10.01

Remove

1. Raise vehicle on a ramp [hoist].

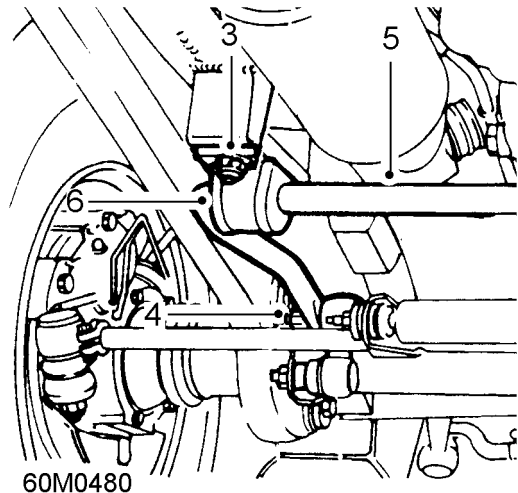

2. Mark anti-roll [sway] bar rubber bushes for reassembly.
3. Remove 4 nuts and bolts securing anti-roll [sway] bar to mounting brackets.
4. Remove 2 nuts and bolts securing anti-roll [sway] bar to ball joint links.
5. Remove anti-roll [sway] bar.
6. Remove rubber bushes from anti-roll [sway] bar.

Refit

7. Fit bushes to anti-roll [sway] bar. Ensure split in bushes points towards axle on RH side, and away from axle on LH side.
8. Position anti-roll [sway] bar and loosely fit nuts and bolts to mounting brackets.



NOTE: Angled sides of bar should point downwards.

9. Using new nuts, fit anti-roll [sway] bar to ball joint links. Tighten to **68 Nm, 50 lbf ft.**
10. Tighten nuts and bolts securing anti-roll [sway] bar to mounting brackets to **30 Nm, 22 lbf ft.**
11. Lower vehicle.

ANTI-ROLL [SWAY] BAR BALL JOINT LINKS

Service repair no - 60.10.04

Remove

1. Raise vehicle on a ramp [hoist].

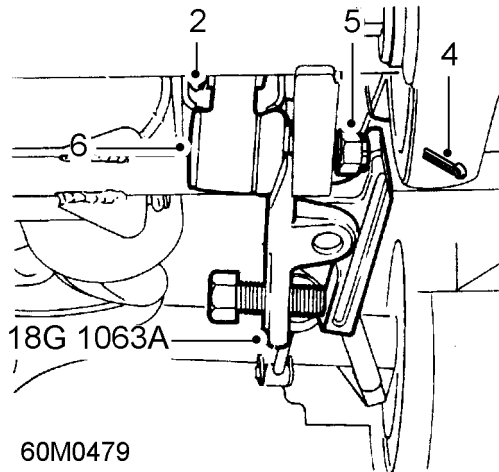

2. Remove 2 nuts and bolts securing ball joint links to anti-roll [sway] bar and collect washers and rubber bushes.
3. Release ball joints using special tool **LRT-57-018**.
4. Remove 2 split pins from castellated nuts.
5. Remove 2 castellated nuts.
6. Remove ball joint links.

Refit

7. Fit ball joint links, ensuring they point upwards.
8. Fit castellated nuts and tighten to **40 Nm, 30 lbf ft.**
9. Fit split pins to castellated nuts.
10. Align anti-roll [sway] bar to ball joint links.
11. Fit bolts, washers, rubber bushes, and new lock nuts securing anti-roll [sway] bar to ball joint links. Tighten bolts to **68 Nm, 50 lbf ft.**
12. Lower vehicle.

PANHARD ROD

Service repair no - 60.10.07

Remove

1. Raise vehicle on a ramp [hoist].

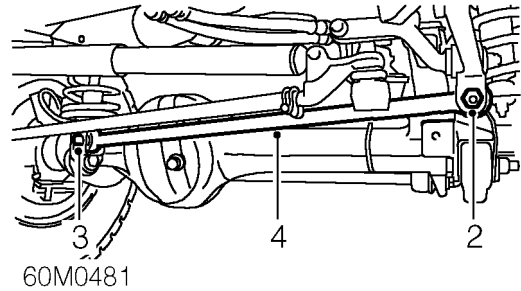

2. Remove bolt securing Panhard rod to mounting arm and collect nut
3. Remove bolt securing Panhard rod to axle bracket and collect nut.
4. Remove Panhard rod.

Do not carry out further dismantling if component is removed for access only.

5. Press out flexible bushes.



CAUTION: Ensure pressure is exerted on outer edge of bush, not rubber inner.

6. Fit replacement bushes.

Refit

7. Position Panhard rod to axle bracket and mounting arm.
8. Fit nut and bolt securing Panhard rod to axle bracket and tighten to **88 Nm, 65 lbf ft.**
9. Fit nut and bolt securing Panhard rod to mounting arm and tighten to **88 Nm, 65 lbf ft.**
10. Lower vehicle.



RADIUS ARM

Service repair no - 60.10.16

Remove

1. Raise front of vehicle.



WARNING: Support on safety stands.

2. Remove road wheel(s).
3. Raise front of vehicle and support axle.

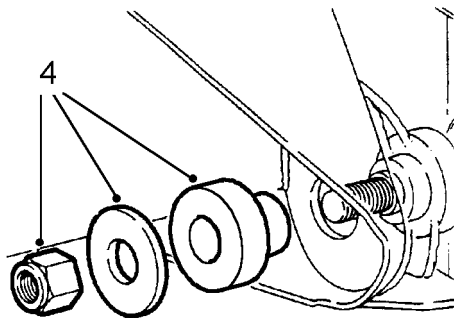

60M0476

4. Remove nut securing radius arm to chassis side member and collect washer and rubber bush.

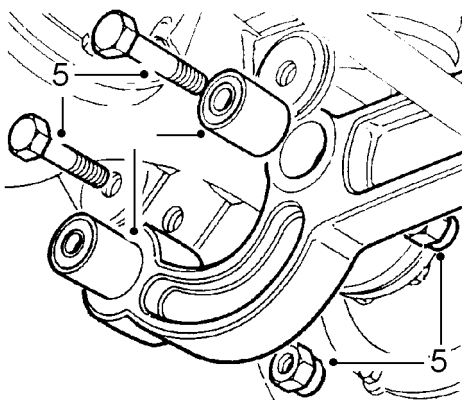

60M0477

5. Remove 2 bolts securing radius arm to axle and collect nuts.

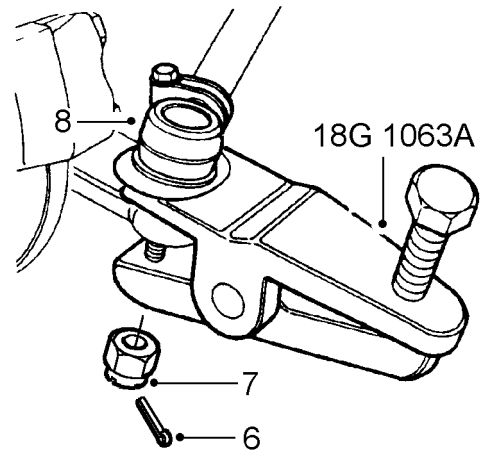

60M0478

6. Remove split [cotter] pin from castellated nut securing track rod to swivel hub.
7. Remove castellated nut securing track rod to swivel hub.
8. Using special tool **LRT-57-018** release track rod from swivel hub.
9. Move track rod aside.
10. Lower front of radius arm to clear axle and remove from vehicle.

Do not carry out further dismantling if component is removed for access only.

11. Press out bushes from radius arm.



CAUTION: Ensure pressure is exerted on outer edge of bushes, and not rubber inner.

12. Press in replacement bushes.

Refit

13. Position radius arm to vehicle.
14. Loosely fit bolts securing radius arm to axle.
15. Connect track rod to swivel hub.
16. Fit and tighten castellated nut securing track rod to swivel hub to **40 Nm, 30 lbf ft.**
17. Fit new split [cotter] pin to castellated nut.
18. Tighten nuts securing radius arm to axle to **197 Nm, 145 lbf ft.**
19. Fit rubber bush and washer to radius arm.
20. Fit and tighten nut securing radius arm to chassis member to **175 Nm, 130 lbf ft.**
21. Remove jack from under axle.
22. Fit road wheel.
23. Remove stand(s) and lower vehicle.

FRONT SHOCK ABSORBER

Service repair no - 60.30.02.

Remove

1. Loosen road wheel retaining nuts.
2. Support chassis on stands and remove road wheel.
3. Support axle weight with jack.

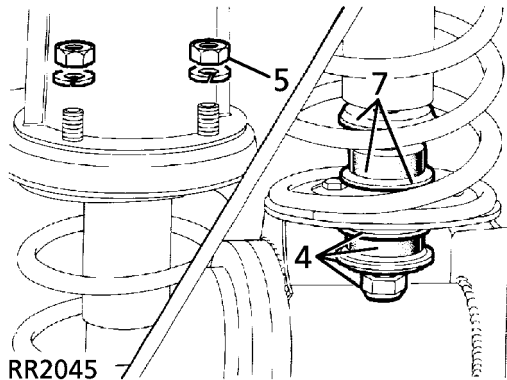

4. Remove shock absorber lower fixing and withdraw cupwasher, rubber bush and seating washer.
5. Remove four shock absorber bracket fixings.

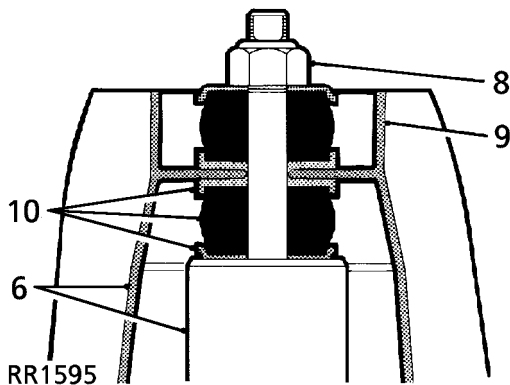

6. Withdraw shock absorber and bracket complete.
7. Withdraw lower seating washer, rubber bush and cupwasher.
8. Remove fixings, shock absorber to mounting bracket.
9. Withdraw mounting bracket.
10. Lift off top seating washer, rubber bush and cupwasher.

Refit

11. Assemble shock absorber components.
12. Position shock absorber, complete with bracket and secure with 4 fixings.
13. Secure shock absorber lower fixing.
14. Fit road wheel, remove chassis stands and jack.



FRONT ROAD SPRING

Service repair no - 60.20.11.

Remove

1. Remove front shock absorber. *See Front shock absorber*



CAUTION: Avoid over stretching brake hoses. If necessary loosen hose connector locknuts to allow hoses to follow axle.

2. Lower axle sufficient to free road spring.
3. Withdraw road spring.
4. Withdraw shock absorber bracket securing ring.

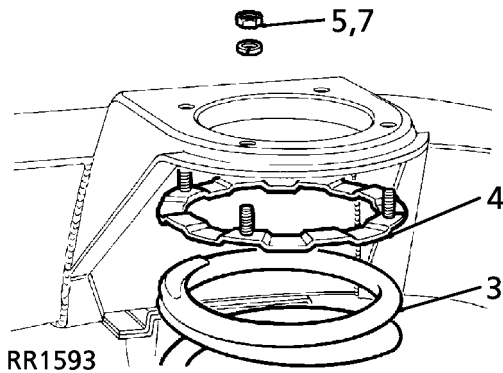

Refit

5. Fit shock absorber bracket retaining ring. Retain in position with a nut.
6. Position road spring and raise axle.
7. Remove nut retaining securing ring.
8. Fit front shock absorber. *See Front shock absorber*

BUMP STOP

Service repair no - 60.30.10.

Remove

1. Remove fixings.
2. Remove bump stop.

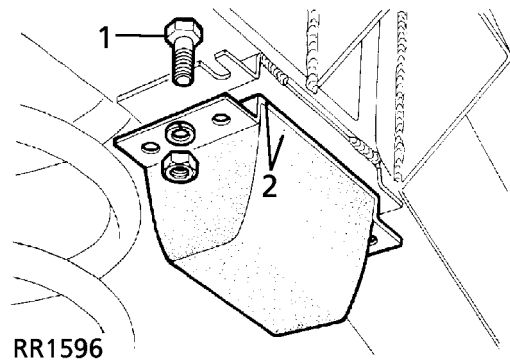

Refit

3. Position bolts in slots in chassis brackets.
4. Fit bump stop, secure with washers and nuts.

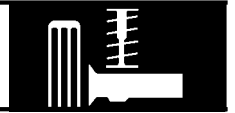

TORQUE VALUES

	Nm	lbf ft
Anti-roll bar front:		
- Mounting brackets	30	22
- Ball link self lock nut	70	50
- Castellated nut	40	30
Drag link to axle	40	30
Securing ring for mounting turret	14	10
Radius arm to chassis	175	130
Panhard rod mounting arm to chassis	90	65
Panhard rod to axle	90	65
Panhard rod to mounting arm	90	65
Tie bar to Panhard rod	110	80
Radius arm to axle	200	150
Road wheel nuts	130	95



DESCRIPTION

The rear suspension locates the rear axle with two round section steel lower link arms and a forged 'A' frame upper link assembly. This system allows maximum axle articulation and wheel travel while maintaining roll stiffness and directional stability.

The link arm is secured by a single retaining nut to the chassis mounting, comprising a rubber bushed bracket, which is retained by three fixings. A ferrule rubber bush with a single retaining bolt is used to secure the link arm to its axle mounting.

The upper link assembly is located on the rear differential housing by a pivot ball-pin assembly. Two brackets, bolted to the chassis crossmember,

support both sides of the 'A' frame of the link assembly, secured by single retaining bolts.

Two rubber bearing bushes with retaining straps, secure the rear of the anti-roll bar, if fitted, to the chassis mountings, while bushed links support the front of the anti-roll [sway] bar to the axle.

Conventional long travel coil springs and hydraulic shock absorbers are used to control body movement. The shock absorbers are secured to chassis mounting brackets and fabricated lower mountings welded to the rear axle. Retaining plates are used to secure the coil springs to the axle mounting while fabricated brackets, welded to the chassis, are used for the upper spring location.

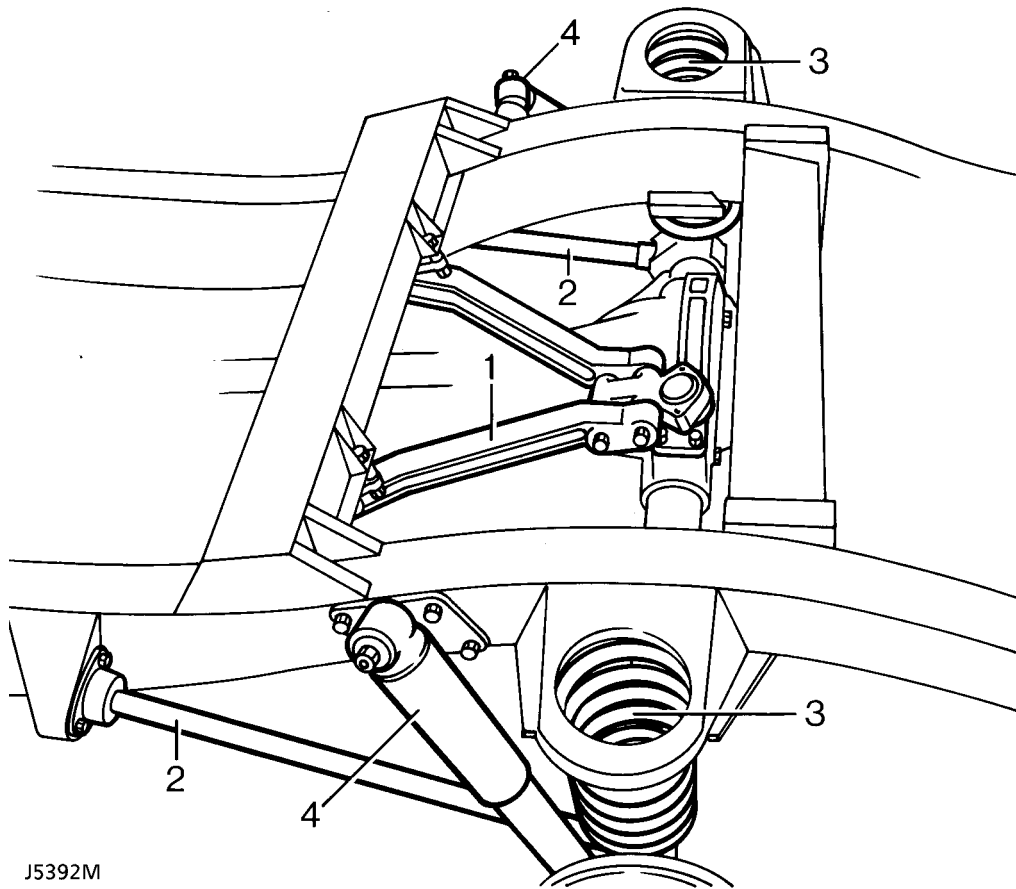

Rear axle suspension

- 1. 'A' frame, upper link assembly
- 2. Lower link
- 3. Coil springs
- 4. Shock absorber



REAR ROAD SPRING

Service repair no - 64.20.01.

Remove

1. Loosen rear road wheel retaining nuts.
2. Support chassis on stands and remove wheels.
3. Support rear axle weight with jack.
4. Disconnect shock absorbers at one end.

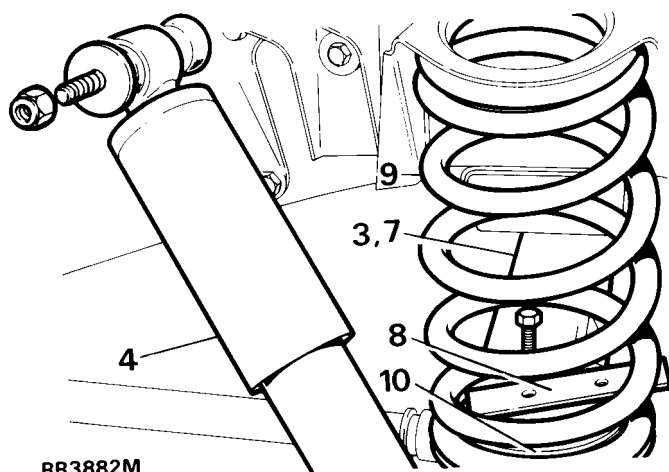

5. Position coil spring compressor correctly on road spring.
6. Compress spring evenly to facilitate removal.
7. Lower axle to free road spring from upper seat.



CAUTION: Avoid lowering axle further than rear brake flexible hose and road speed sensor leads will allow.

8. Remove spring retainer plate.
9. Withdraw road spring.
10. Collect off spring seat.

Refit

11. Position spring seat on axle location.
12. Fit road spring into chassis location and using a turning motion, fit to spring seat.
13. Fit spring retainer plate.
14. Secure shock absorber. Tighten to **37 Nm, 27 lbf ft**
15. Fit road wheels. Tighten to **130 Nm, 95 lbf ft**.
16. Remove chassis stands and jack.

REAR SHOCK ABSORBER

Service repair no - 64.30.02.

Remove

1. Loosen road wheel retaining nuts.
2. Support chassis on stands. Remove road wheel and support rear axle weight with jack.
3. Remove fixings and withdraw shock absorber from axle bracket.

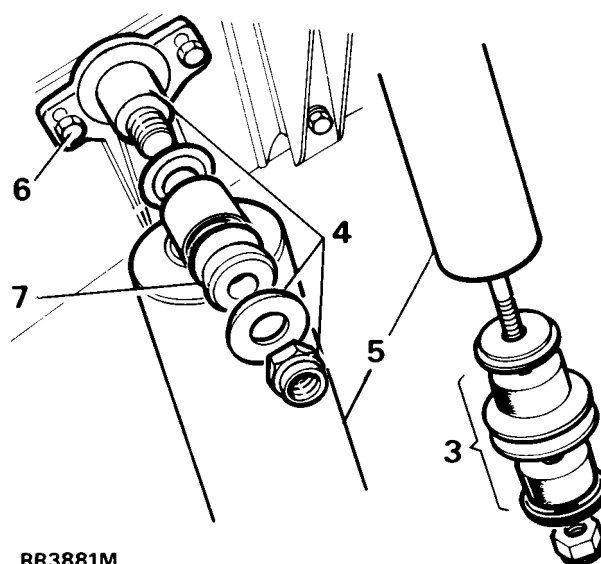

4. Remove upper fixings.
5. Withdraw shock absorber.
6. If required remove mounting bracket
7. If required remove mounting rubbers.

Refit

8. Position shock absorber and fit upper fixings.
9. Secure shock absorber with lower fixings to axle bracket. Tighten to **37 Nm, 27 lbf ft**.
10. Fit road wheels. Tighten to **130 Nm, 95 lbf ft**.
11. Remove chassis stands and jack.

SUSPENSION LINK - UPPER

Service repair no - 64.35.44.

Remove

1. Support rear of chassis on stands, allow axle to hang freely.

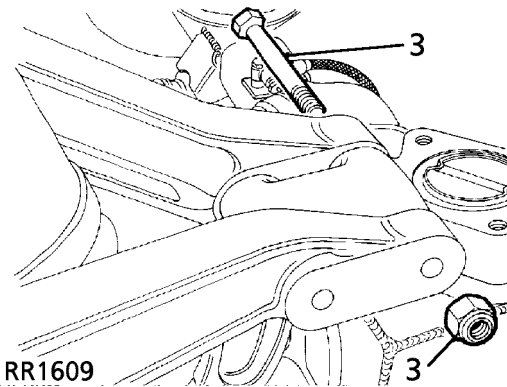
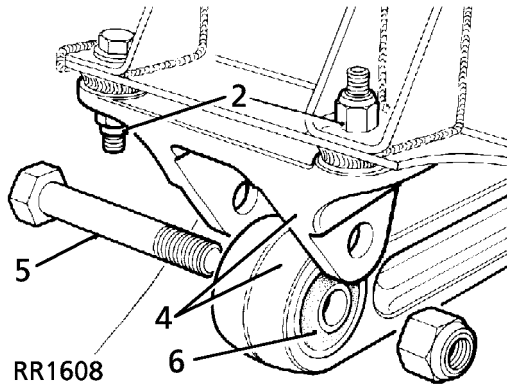

2. Remove fixings, upper link bracket to frame.
3. Remove fixings, upper links to pivot bracket.
4. Remove upper link complete with frame bracket.
5. Remove bolt.
6. Separate link from bracket.

Renew bush

7. Press out rubber bushes.
8. Fit bush centrally in housing.



CAUTION: Apply pressure to outer edge of bush, and not rubber inner.

Refit



NOTE: Do not fully tighten fixings until all components are in position.

9. Secure link to frame bracket.
10. Fit upper link to pivot bracket.
11. Fit frame bracket to chassis mounting.
12. Fully tighten fixings to correct torque. **See Specifications, torque, Torque values.**

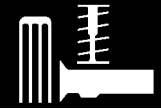

SUSPENSION LINK - LOWER

Service repair no - 64.35.02.

Remove

1. Site vehicle on a ramp [hoist].
2. Alternatively, support vehicle on stands under rear axle.

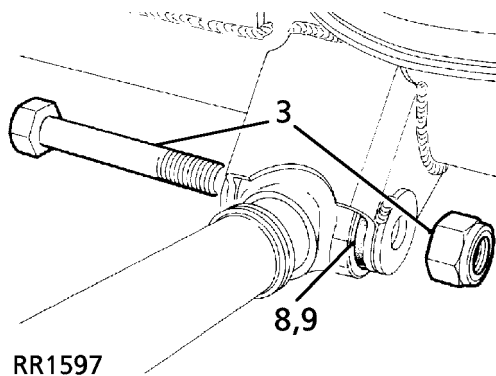

3. Remove lower link rear fixings.

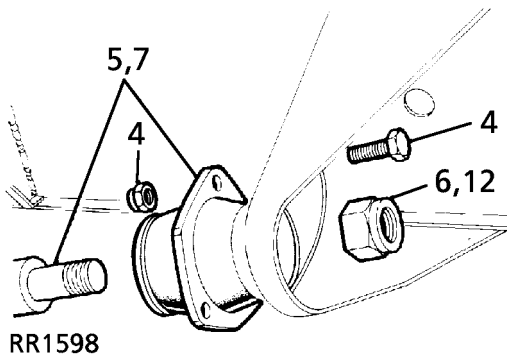

4. Remove mounting bracket fixings at side member bracket.
5. Remove lower link complete.
6. Remove locknut.
7. Remove mounting bracket from lower link.

Renew bush

8. Press out rubber bushes.
9. Fit bush centrally in housing.



CAUTION: Apply pressure to outer edge of bush, and not rubber inner.

Refit

10. Fit mounting rubber to lowerlink.
11. Secure mounting rubber to chassis bracket, but do not fully tighten locknut.
12. Fit lower link to axle mounting and secure fixing to **175 Nm, 130 lbf ft.**
13. Lower vehicle, allow axle to take up static laden position, and fully tighten link chassis fixing to **175 Nm, 130 lbf ft.**

ANTI-ROLL [SWAY] BAR

Service repair no - 64.35.08

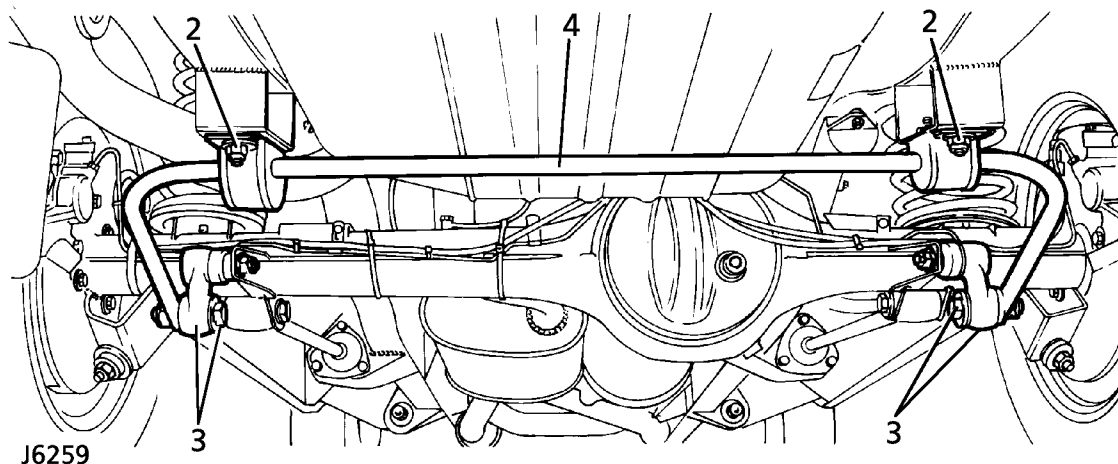

J6259

Remove

1. Note for reassembly, position of rubber bushes on anti-roll [sway] bar.
2. Remove 4 nuts, bolts and washers securing 2 bush straps to chassis mountings.
3. Remove nuts, bolts, washers and rubber bushes from the ball joint links.
4. Remove anti-roll [sway] bar.

Refit

5. Position rubber bushes on anti-roll [sway] bar. Fit joint towards axle.
6. Fit anti-roll [sway] bar with 2 straps. Ensure ball joint link arms point down as shown in J6259. Loosely fit, bolts, washers and NEW nyloc nuts.
7. Fit bolt, washers and rubber bushes. Fit anti-roll [sway] bar to ball joint links and tighten to **68Nm, 50 lbf ft**.
8. Tighten nuts securing straps to **30Nm, 22 lbf ft**.



ANTI-ROLL [SWAY] BAR BALL JOINT LINKS

Service repair no - 64.35.24.

Remove

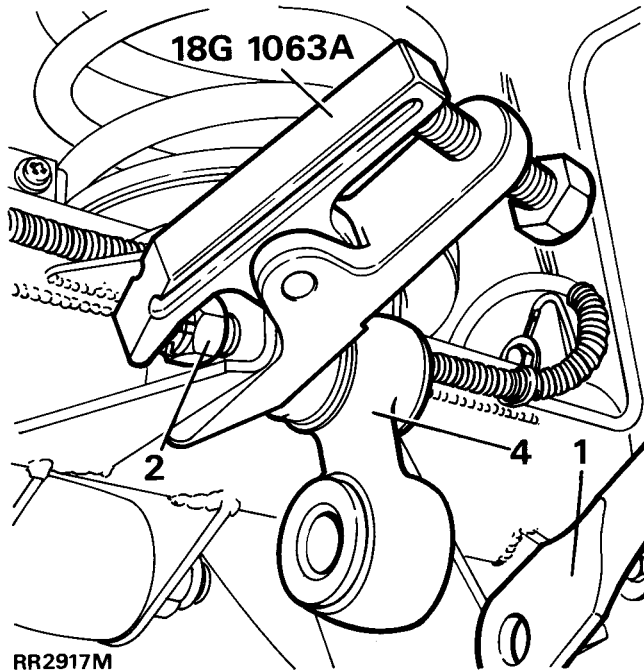

1. Remove 2 nuts, bolts, washers and rubber bushes from ball joint links and lower anti-roll [sway] bar to clear links.
2. Remove cotter pin and loosen castellated nut a few turns.
3. Release ball joint using special tool **18G 1063A** as shown.
4. Remove castellated nut and ball joint link.

Refit

5. Fit ball joint link arm and castellated nut. Point ball joint link arm down as shown. Tighten fixing to **40 Nm, 30 lbf ft** and fit new cotter pin.
6. Align anti-roll bar to ball joint links.
7. Fit bolts, washers and rubber bushes using new self locking nuts and secure anti-roll [sway] bar to ball joint links. Tighten to **68Nm, 50 lbf ft**.



TORQUE VALUES

Rear Suspension

	Nm	lbf ft
Anti-roll [sway] bar:		
- Strap nyloc nuts	30	22
- Ball link self lock nut	68	50
- Castellated nut	40	30
Top link to mounting bracket	175	130
Bottom link to axle	175	130
Bottom link to chassis	175	130
Top link bracket to rear cross member	47	35
Shock absorber to axle	37	27
Road wheel nuts	130	95



DESCRIPTION

The mechanical components of the hydraulic braking system consist of four piston caliper disc brakes at the front and two piston caliper disc brakes at the rear. The front brake discs are vented.

A cable controlled parking brake operates a single drum brake mounted on the rear output shaft of the transfer gearbox and is completely independent of the main braking system.

The basic hydraulic system involves 2 separate and independent primary and secondary circuits which permits a degree of braking should a fault occur in one of the circuits. The primary circuit operates the rear brake calipers and the secondary circuit the front brake calipers.

Master cylinder

A tandem master cylinder, which is assisted by a lightweight compact servo, is fed by a divided fluid reservoir. The rear section supplies fluid for the primary circuit and the front section the secondary circuit.

Master cylinder components

1. Secondary plunger
2. Secondary spring
3. Recuperation seal - secondary
4. Primary spring
5. Recuperation seal - primary
6. Primary plunger

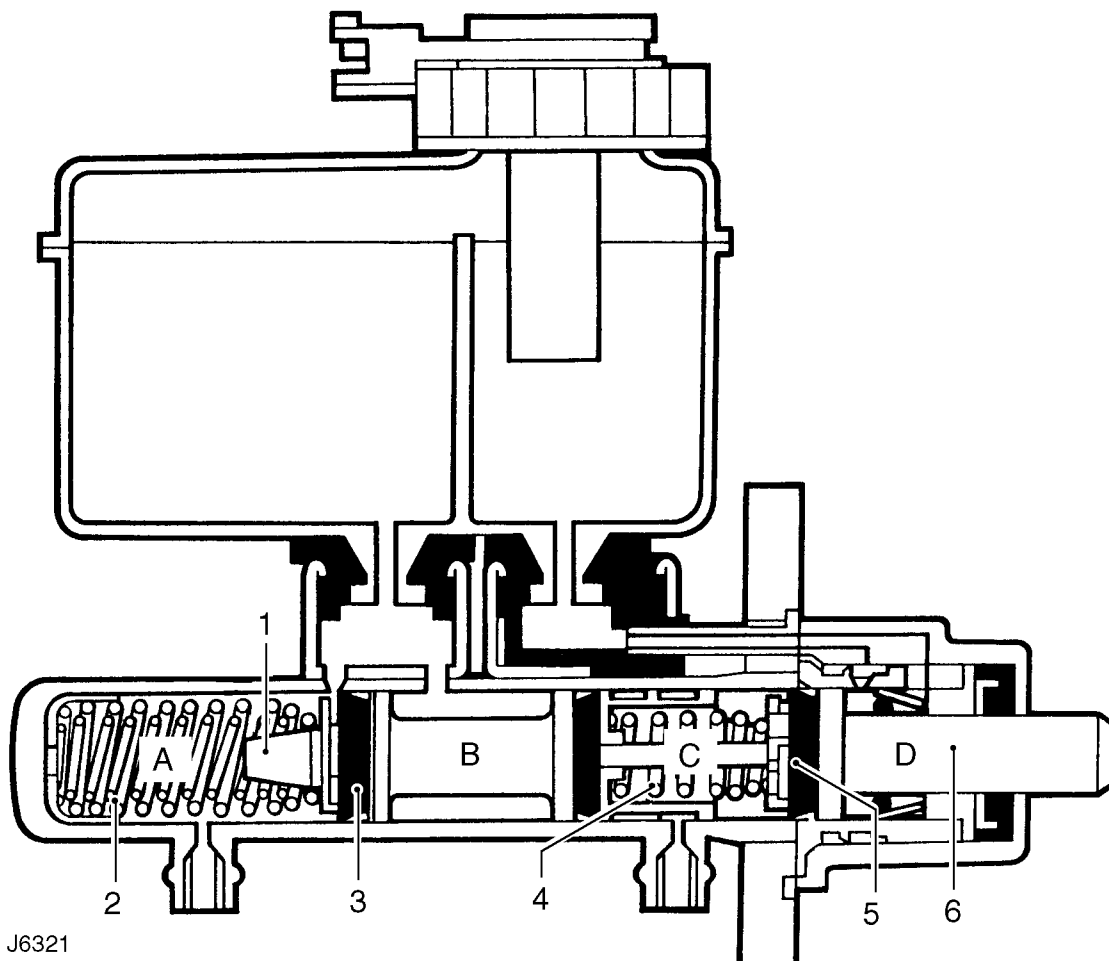

J6321

When the brakes are off, the fluid can move unrestricted between the dual line system and the separate reservoirs in the fluid supply tank. When the footbrake is applied, the primary plunger assembly moves up the cylinder bore and the pressure created acts in conjunction with the primary spring to overcome the secondary springs, thus moving the secondary plunger assembly up the bore at the same time. Initial movement of both plungers takes the recuperating seals past the cut-off holes in the cylinder chambers 'A' and 'C', and applies pressure to the fluid in those chambers, which is directed to the respective cylinders of each of the separate circuits.

The fluid in chambers 'B' and 'D' is unaffected by movement of the plungers and can move unrestricted between the separate chambers and respective reservoirs in the fluid supply tank, both before and during brake application. When the brakes are released, the plunger assemblies, aided by the return springs are retracted faster than the fluid; this creates a depression between the fluid in chambers 'A' and 'C' and the recuperation seals.

The recuperation seals momentarily collapse allowing fluid in chambers 'B' and 'D', which is unaffected by the movement of the plungers, to flow through the holes in the plungers, over the collapsed seals and into chambers 'A' and 'C' respectively. The movement of fluid from one set of chambers to the other, is compensated for by fluid from the separate reservoirs in the supply tank moving through the feed holes in the cylinder. Conversely, the final return movement of the plunger assemblies causes the extra fluid in chambers 'A' and 'C' to move through the cut off holes into the fluid reservoir.

The servo unit provides controlled power assistance to the brake pedal when pressure is applied. Vacuum is obtained from the depression in the inlet manifold. The vacuum is applied to both sides of a flexing diaphragm and by admitting atmospheric pressure to the rear diaphragm, assistance is obtained. The servo unit is mounted between the brake pedal and master cylinder and is linked to these by push rods. Should a vacuum failure occur, the two push rods will act as a single rod allowing the brakes to function in the normal way, although more effort will be required to operate the brake pedal.



Hydraulic system

A brake fluid loss switch is fitted to the master cylinder reservoir filler cap. The switch is wired to a warning light on the vehicle fascia and will illuminate momentarily when ignition is switched on and indicates that the warning circuit is functioning correctly. A hydraulic failure in the system will result in fluid loss, causing the warning light to illuminate.

A pressure reducing valve (PRV), fitted to the RH bulkhead in the engine compartment, maintains the braking balance, see J6322. Pressure to the rear calipers is regulated by the PRV, this valve is of the failure by-pass type allowing full system pressure to the rear brake calipers in the event of a front (secondary) circuit failure.

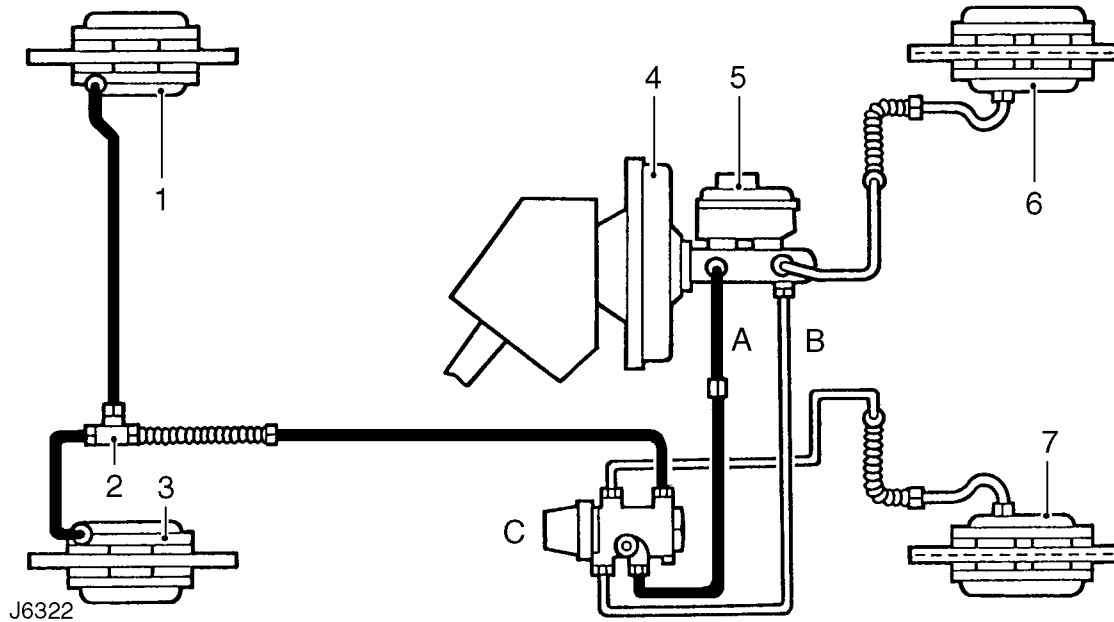

- A. Primary circuit
- B. Secondary circuit
- C. Pressure reducing valve (PRV)

- 1. LH rear brake caliper
- 2. T-connector
- 3. RH rear brake caliper
- 4. Brake servo
- 5. Master cylinder and reservoir
- 6. LH front brake caliper
- 7. RH front brake caliper



GENERAL BRAKE SERVICE PRACTICE

Brake fluid precautions

WARNING: Do not allow brake fluid to come into contact with eyes or skin.



CAUTION: Brake fluid can damage paintwork, if spilled wash off immediately with plenty of clean water.



CAUTION: Use only correct grade of brake fluid. If an assembly fluid is required use **ONLY** brake fluid. Do **NOT** use mineral oil, i.e. engine oil etc.



CAUTION: Thoroughly clean all brake calipers, pipes and fittings before commencing work on any part of the brake system. Failure to do so could cause foreign matter to enter the system and cause damage to seals and pistons which will seriously impair the efficiency of the brake system. To ensure the brake system efficiency is not impaired the following warnings must be adhered to :-

- **DO NOT** use any petroleum based cleaning fluids or any proprietary fluids containing petrol.
- **DO NOT** use brake fluid previously bled from the system.
- **DO NOT** flush the brake system with any fluid other than the recommended brake fluid.

The brake system should be drained and flushed at the recommended service intervals.

Cover all electrical terminals carefully to make absolutely certain that no fluid enters the terminals and plugs.

FLUID LEVEL CHECK / TOP-UP



WARNING: Clean reservoir body and filler cap before removing cap. Use only fluid from a sealed container.

1. Park vehicle on level ground.
2. Check level is between 'MIN' and 'MAX' marks.
3. If level is below 'MIN' mark top up fluid level to 'MAX' mark on reservoir, using correct fluid. **See LUBRICANTS, FLUIDS AND CAPACITIES, Information, Brake fluid reservoir**



CAUTION: Do not fill reservoir above maximum line.

BRAKE SYSTEM BLEED

Service repair no - 70.25.02

Preparation



WARNING: Before bleeding the brake system refer to general brake service practice. See *General Brake Service*

Practice

- During bleed procedure, brake fluid level must not be allowed to fall below the MIN level. Keep reservoir topped to the MAX level.
- To bleed the hydraulic circuits, four bleed nipples are provided, one at each caliper.
- There are two methods by which air can be removed from the braking system:-

1. **MANUAL BLEED PROCEDURE.**
2. **PRESSURE BLEED PROCEDURE.**

Pressure bleed procedure

Purpose designed equipment for pressure filling and bleeding of hydraulic systems may be used on Land Rover vehicles. The equipment manufacturer's instructions must be followed and the pressure must not exceed 4.5 bar, 65 lbf/in².

Manual bleed procedure

Equipment required

- Clean glass receptacle
- Bleed hose
- Wrench
- Approx 2 litres brake fluid **See LUBRICANTS, FLUIDS AND CAPACITIES, Information, Recommended lubricants and fluids**

Master cylinder bleed

1. Disconnect battery.
2. Depress brake pedal fully and slowly 5 times.
3. Release the pedal and wait for ten seconds.
4. Air bubbles will rise into the reservoir during these instructions.
5. Repeat instructions until a firm resistance is felt at the pedal.

Complete circuit bleed

1. Fit bleed hose to any caliper bleed screw.
2. Dip free end of bleed hose into brake fluid in bleed bottle.
3. Open bleed screw of caliper.
4. Depress brake pedal fully several times until fluid is clear of air bubbles.
5. Keeping pedal fully depressed, tighten bleed screw, then release pedal.
6. Repeat the above procedure on remaining 3 calipers.
7. Fit all bleed screw protection caps.
8. Check/top-up fluid level when bleeding is complete. **See Fluid Level Check / Top-Up**



MASTER CYLINDER

Service repair no - 70.30.08

Before starting repair refer to general brake service practice **See General Brake Service Practice**

Remove

1. Disconnect battery.
2. Place a container under the master cylinder to catch escaping brake fluid.

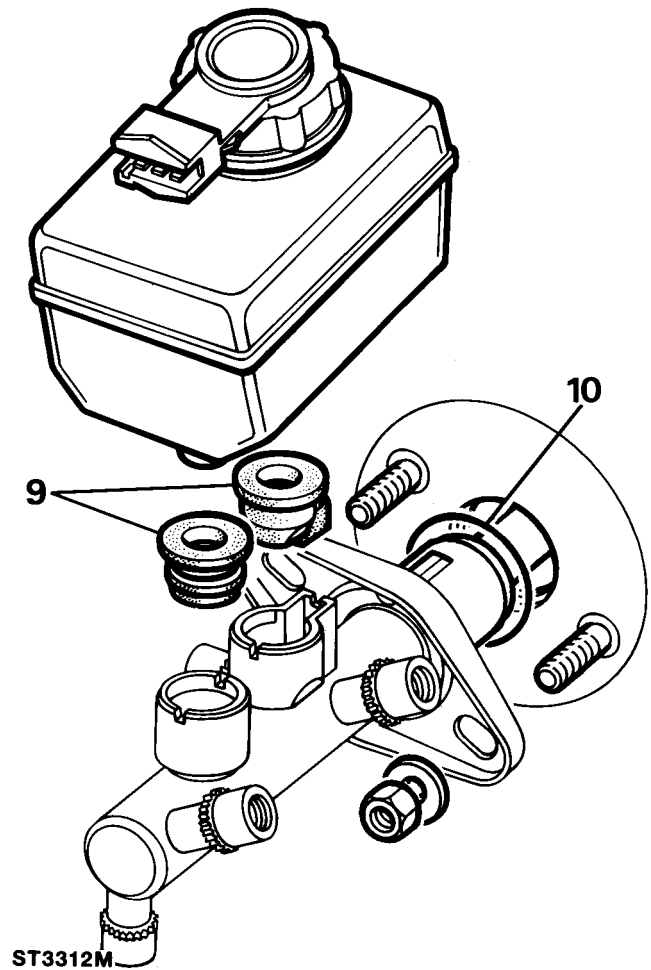
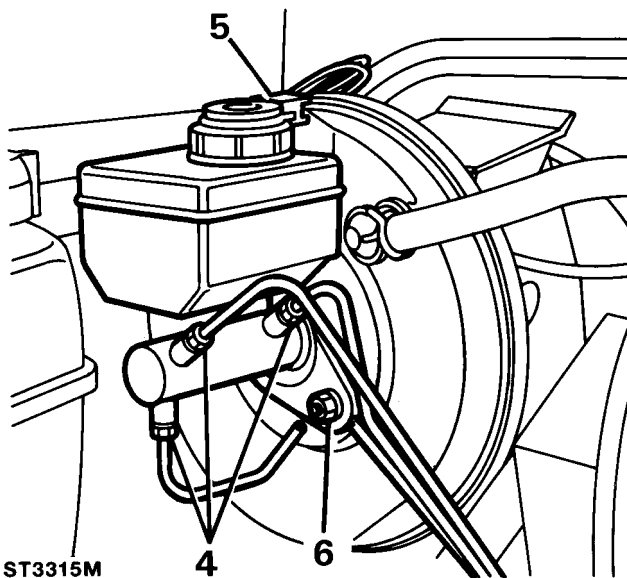

3. Clean area round master cylinder ports.
4. Disconnect pipes from master cylinder ports. Cover, not plug, the pipe ends to prevent entry of dirt.
5. Disconnect electrical leads from reservoir cap.
6. Remove two nuts securing master cylinder to servo and withdraw cylinder.
7. Remove reservoir cap and drain fluid into suitable container for disposal.
8. The reservoir is a push fit in the master cylinder and secured by seals. Carefully ease the reservoir from the master cylinder by rolling it from the seals. Note that the two seals are different in size.

Refit

9. Insert new reservoir seals in the master cylinder ports and fit reservoir to master cylinder.
10. Ensuring that water ingress seal is in position, fit master cylinder to servo. Tighten fixings to **26 Nm, 19 lbf/ft.**
11. Connect brake pipes to master cylinder ports and tighten to **15 Nm, 11 lbf/ft.**
12. Fit electrical leads to reservoir cap
13. Fill reservoir with recommended brake fluid. **See LUBRICANTS, FLUIDS AND CAPACITIES, Information, Recommended lubricants and fluids**
14. Bleed the brake system **See Brake system bleed**
15. Reconnect battery and road test vehicle.

PRESSURE REDUCING VALVE (PRV)

Service repair no - 70.25.21

Remove

1. Disconnect battery.
2. Clean reducing valve parts.
3. Place a container under PRV valve to catch escaping brake fluid.

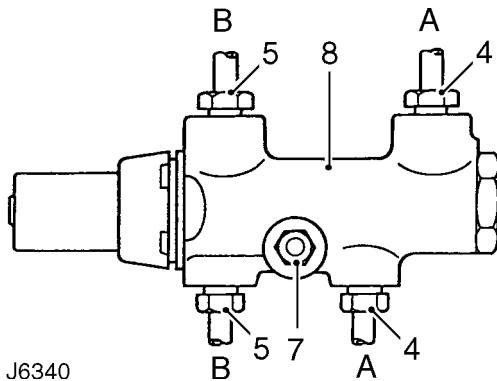

J6340

4. Disconnect primary circuit pipe unions æAæ from PRV.
5. Disconnect secondary circuit pipe unions æBæ from PRV.
6. Cover pipes to prevent ingress of dirt.
7. Remove single retaining nut and bolt securing PRV to engine bulkhead.
8. Remove valve.

Refit

9. Fit valve to engine bulkhead. Tighten bolt to **15 Nm, 11 lbf/ft.**
10. Connect primary and secondary circuit pipes to PRV. Tighten to **16 Nm, 12 lbf/ft.**
11. Fill brake reservoir with recommended brake fluid. **See LUBRICANTS, FLUIDS AND CAPACITIES, Information, Recommended lubricants and fluids**
12. Bleed the brake system. **See Brake system bleed**
13. Reconnect battery and road test vehicle.

SERVO NON RETURN VALVE

Service repair no - 70.50.15

Remove

1. Disconnect brake vacuum hose from servo non-return valve.

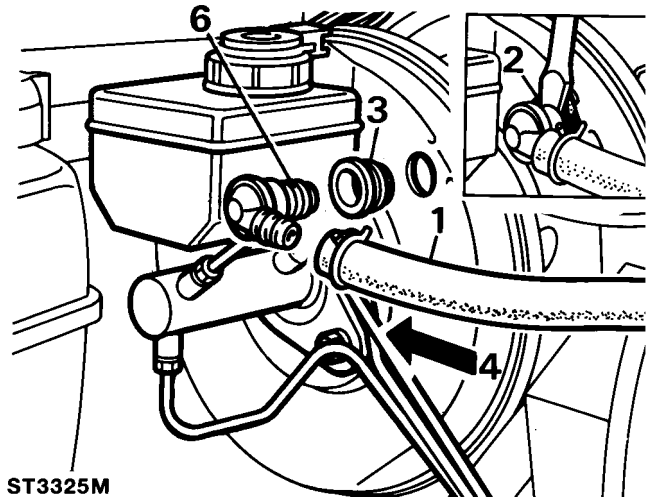

ST3325M

2. Carefully prise valve out with a screwdriver blade between valve and grommet. Take care not to exert too much pressure on the vacuum chamber.
3. Remove rubber grommet but be careful not to allow it to fall into the vacuum chamber.
4. Check the valve for correct operation; it should not be possible to pass air through into the servo in direction of arrow.



WARNING: Do not use compressed air.

Refit

5. Fit rubber grommet.
6. Smear ribs of the valve with Lucas Girling grease to assist assembly, and push valve fully home.
7. Connect vacuum hose to the valve.
8. Road test vehicle.



SERVO ASSEMBLY

Service repair no - 70.50.01

Remove

Before starting repair refer to general brake service practice. **See General Brake Service Practice**



NOTE: The non-return valve and grommet, are the only serviceable components, in event of failure or damage, fit a new unit.

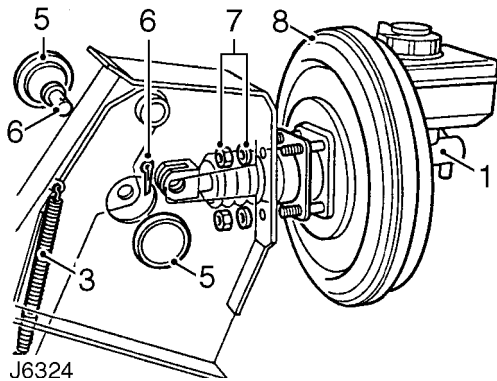

1. Remove master cylinder. **See Master cylinder**
2. Disconnect vacuum supply hose from servo unit.
3. At footwell, release 2 brake pedal return springs.
4. Disconnect leads from brake light switch at rear of pedal box.
5. Remove blanking grommets from each side of pedal box.
6. Remove split pin and clevis pin securing servo push rod to brake pedal.
7. Remove 4 nuts and plain washers securing servo to pedal box.
8. Remove servo assembly and rubber washer from bulkhead.

Refit

9. Locate servo assembly and rubber washer to engine bulkhead and secure to pedal box. Tighten fixings to **14 Nm, 10 lbf/ft.**
10. Fit brake pedal to servo push rod with clevis pin and new split pin.
11. Fit blanking grommets to each side of pedal box.
12. At footwell, attach pedal return springs.
13. Connect vacuum hose to servo non-return valve.
14. Fit brake master cylinder to servo unit. **See master cylinder**

BRAKE PEDAL

Service repair no - 70.35.01 - Brake pedal

Service repair no - 70.35.03 - Pedal box

Remove

1. Remove brake servo assembly. **See Brake servo assembly**
2. Remove 6 bolts securing pedal box to engine bulkhead.
3. Taking care not damage brake fluid pipes, remove pedal box assembly and gasket.

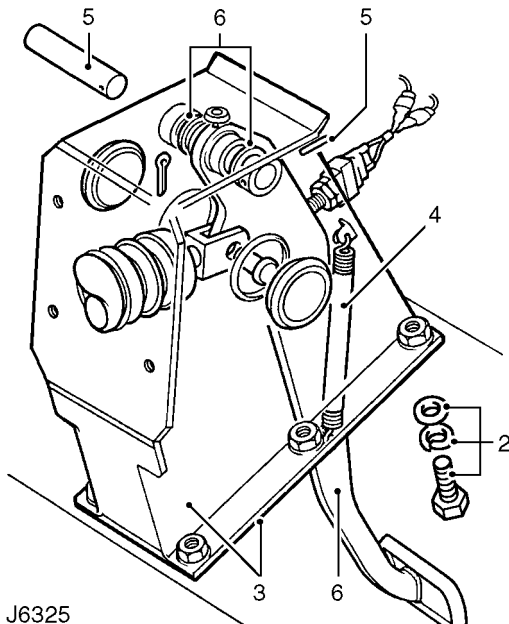

4. Release return springs from pedal and pedal box bosses.
5. Using a suitable punch, drift out retaining pin and withdraw pedal pivot shaft.
6. Remove brake pedal complete with pivot bushes.
7. Examine components for wear or damage, renew as necessary.
8. If it is necessary to fit new pivot bushes, they must be reamed out to $15,87 \text{ mm} \pm 0,02 \text{ mm}$, $0,625 \pm 0,001 \text{ in}$ after fitment.

Refit

9. Lubricate pedal pivot shaft and bushes with general purpose grease.
10. Fit pedal to pedal box, insert pivot shaft and secure with new split pin.
11. Attach return springs to pedal and pedal box bosses.
12. Fit pedal box and gasket to engine bulkhead. Tighten fixings to **25 Nm, 18 lbf/ft.**
13. Fit brake servo assembly. **See Brake servo assembly**



FRONT BRAKE PADS

Service repair no - 70.40.02

Remove

1. Remove front road wheels .
2. Clean exterior of calipers.

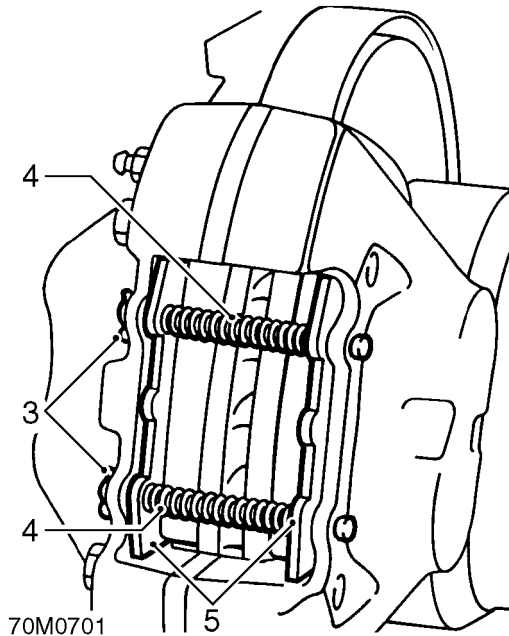

3. Remove split [cotter] pin from retaining pins.
4. Remove pad retaining pins and anti-rattle springs.
5. Remove brake pads.
6. Clean exposed parts of pistons, using new brake fluid. Wipe away excess with a lint free cloth.

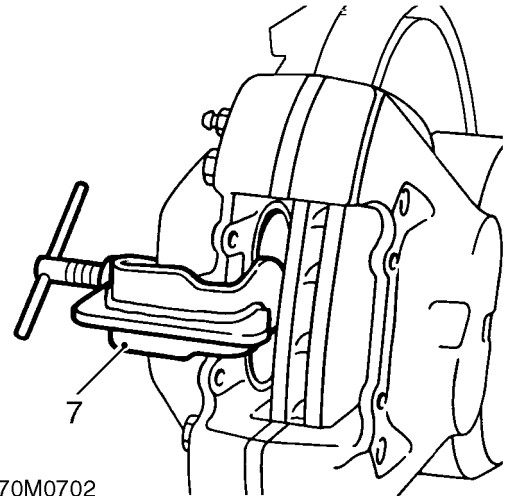

7. Using piston clamp **LRT-70-500** press each piston back into its bore. Ensure that displaced brake fluid does not overflow from reservoir.

Refit

8. Fit brake pads.
9. Fit pad retaining pins and anti-rattle springs. Secure with new split [cotter] pins.
10. Apply service brake pedal several times to locate pads.
11. Check fluid reservoir. Top-up if necessary, using correct grade of fluid. **See LUBRICANTS, FLUIDS AND CAPACITIES, Information, Recommended lubricants and fluids**

REAR BRAKE PADS

Service repair no - 70.40.03

Remove

1. Remove rear road wheels.
2. Clean exterior of calipers.

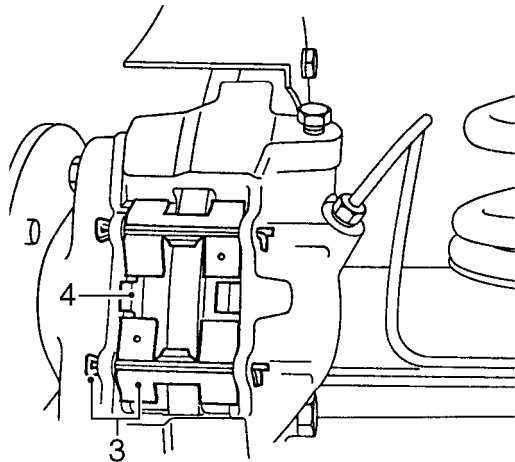

J6327

3. Remove pad retaining pins and anti-rattle springs.
4. Remove brake pads.
5. Clean exposed parts of pistons, using new brake fluid. Wipe away excess with a lint free cloth.
6. Using piston clamp **LRT-70-500** press each piston back into its bore. Ensure that displaced brake fluid does not overflow from reservoir.

Refit

7. Insert brake pads.
8. Position pad retaining springs, fit new pins and spread ends.
9. Apply brake pedal several times to locate pads.
10. Fit road wheels. **130 Nm, 95 lbf ft.**
11. Check fluid reservoir, top up if necessary, using correct grade of fluid **See LUBRICANTS, FLUIDS AND CAPACITIES, Information, Recommended lubricants and fluids**



FRONT BRAKE CALIPER ASSEMBLY

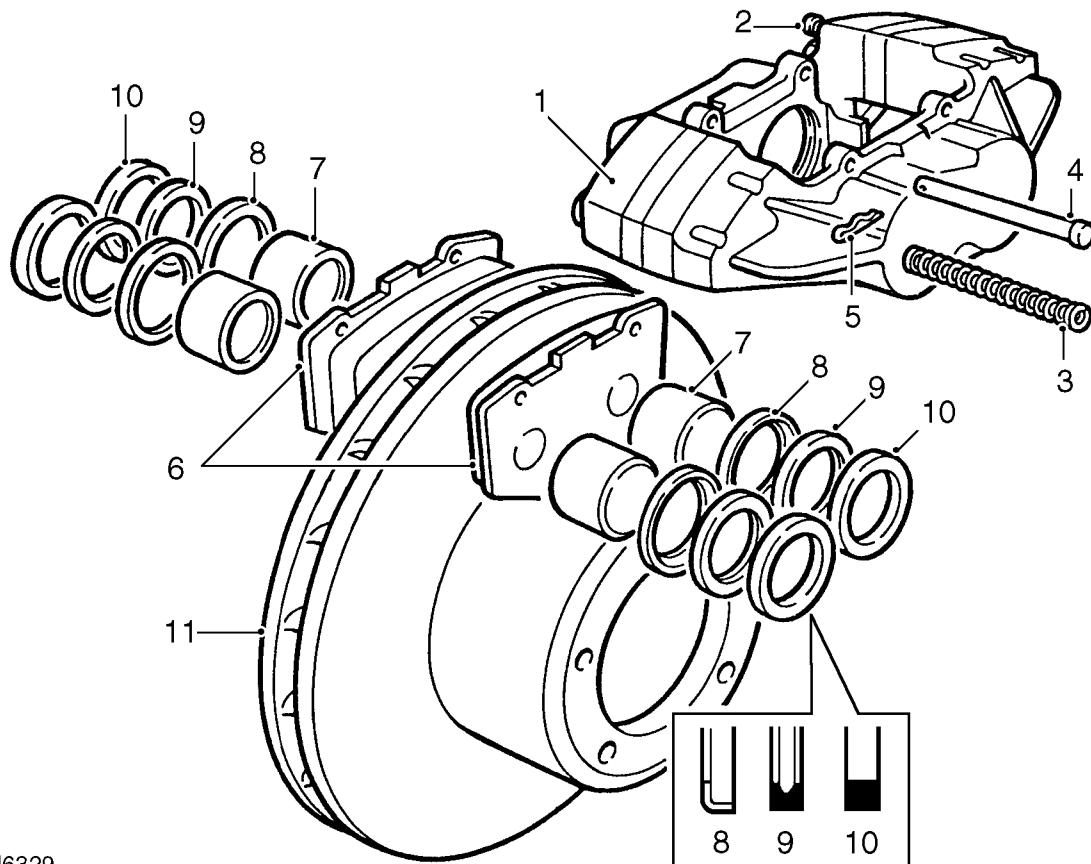

J6329

Key to caliper

- | | |
|------------------------|------------------------|
| 1. Caliper | 7. Piston |
| 2. Bleedscrew | 8. Wiper seal retainer |
| 3. Anti-rattle springs | 9. Wiper seal |
| 4. Pad retaining pins | 10. Fluid seal |
| 5. Split [cotter] pin | 11. Brake disc |
| 6. Friction pads | |

FRONT BRAKE CALIPERS

Service repair no - 70.55.05

Service repair no - 70.55.16

Before starting repair refer to general brake service practice. **See General Brake Service Practice**

Remove

1. Remove front road wheels.
2. Expose flexible brake hose by moving coiled protective covering.
3. Using a hose clamp, clamp hose to prevent loss of brake fluid.

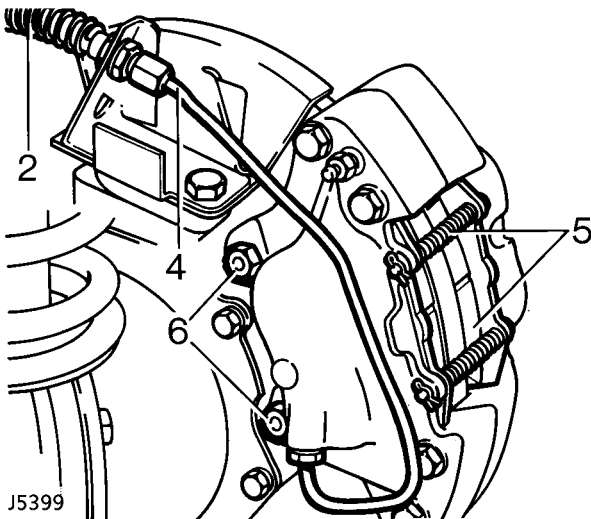

4. Disconnect rigid brake pipe from flexible hose, seal exposed ends to prevent ingress of dirt.
5. Remove split [cotter] pin, retaining pins and springs, withdraw pads. If refitting pads, identify them for assembly to original locations.
6. Remove 2 bolts and withdraw caliper from swivel housing.

Refit



WARNING: Do not separate caliper halves

7. Clean outer surfaces of caliper using aerosol brake cleaner.
8. Using special tool **LRT-70-500**, clamp pistons in inboard half of caliper. Gently, keeping fingers clear, and with **CAUTION**, apply air pressure to fluid inlet port to expel pistons. It is unlikely that pistons will expel at same time. Regulate rate with a suitable piece of wood between appropriate piston and caliper.

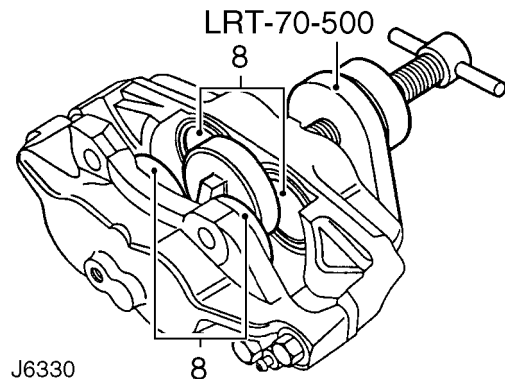

9. Finally remove pistons, identifying them with their respective bores.
10. Remove wiper seal retainer by inserting a blunt screwdriver between retainer and seal. Pry retainer carefully from mouth of bore.
11. Taking care not to damage seal grooves, extract wiper seal and fluid seal.
12. Clean bores, pistons and seal grooves using clean brake fluid only. If caliper or pistons are corroded, or their condition is not perfect, new parts must be fitted.



Assemble outboard pistons

13. Coat new fluid seal with brake fluid. Ease seal into groove in bore using only fingers, ensuring it is properly seated. Fluid seal and groove are not same in section, so when seal is seated it feels raised to touch at edge furthest away from mouth of bore.
14. Coat appropriate piston with brake fluid. Insert it squarely into bore by hand only. Do not tilt piston during insertion, leave approximately 8mm projecting from bore.
15. Coat new wiper seal with brake fluid and fit to new seal retainer. Slide assembly, seal first, over protruding piston and into bore recess. Use piston clamp to press home seal retainer and piston.

Mounting inboard pistons

16. Clamp outboard pistons and carry out same procedure for removing and fitting outboard pistons and seals, instructions 8 to 15.

Fit calipers and pads

17. Fit caliper, tighten bolts evenly to **82 Nm, 60 lbf/ft.**
18. Connect brake flexible hoses to caliper. Tighten to **15 Nm, 11 lbf/ft.**
19. Remove hose clamps.
20. Insert pads. Fit pins and springs, secure using new split [cotter] pin.
21. Bleed brake system. **See Brake System Bleed**
22. Press brake pedal firmly several times to locate friction pads.
23. Fit road wheels, remove axle stands. Finally tighten road wheel nuts to **130 Nm, 96 lbf/ft.**
24. Road test vehicle. Note that new friction pads require 'bedding-in', this may take several hundred miles before brakes are at maximum efficiency.

FRONT BRAKE DISCS

Service repair no - 70.10.10.

Remove

1. Remove hub assembly. **See FRONT AXLE AND FINAL DRIVE, Repair, Front hub assembly**
2. Remove 5 hub to disc bolts.
3. Tap disc to separate from hub.

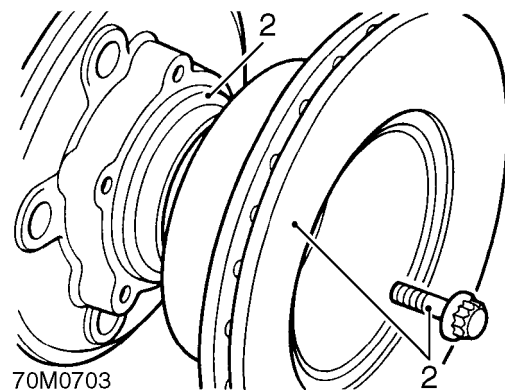

Refit

4. Locate disc to hub.
5. Apply Loctite 270 to disc bolts and tighten to **73 Nm, 54 lbf/ft.**
6. Check total disc runout with a dial indicator, this must not exceed 0,15 mm, 0.006 in. If necessary reposition disc.
7. Fit hub assembly **See FRONT AXLE AND FINAL DRIVE, Repair, Front hub assembly**

Disc reclamation

8. Check disc thickness. This dimension may be machined to minimum thickness of 22 mm, 0.875 in - ventilated discs. Machine equal amount off each face.



NOTE: The disc MUST BE renewed if the minimum running thickness stamped on the disc is recorded.

REAR BRAKE CALIPER ASSEMBLY

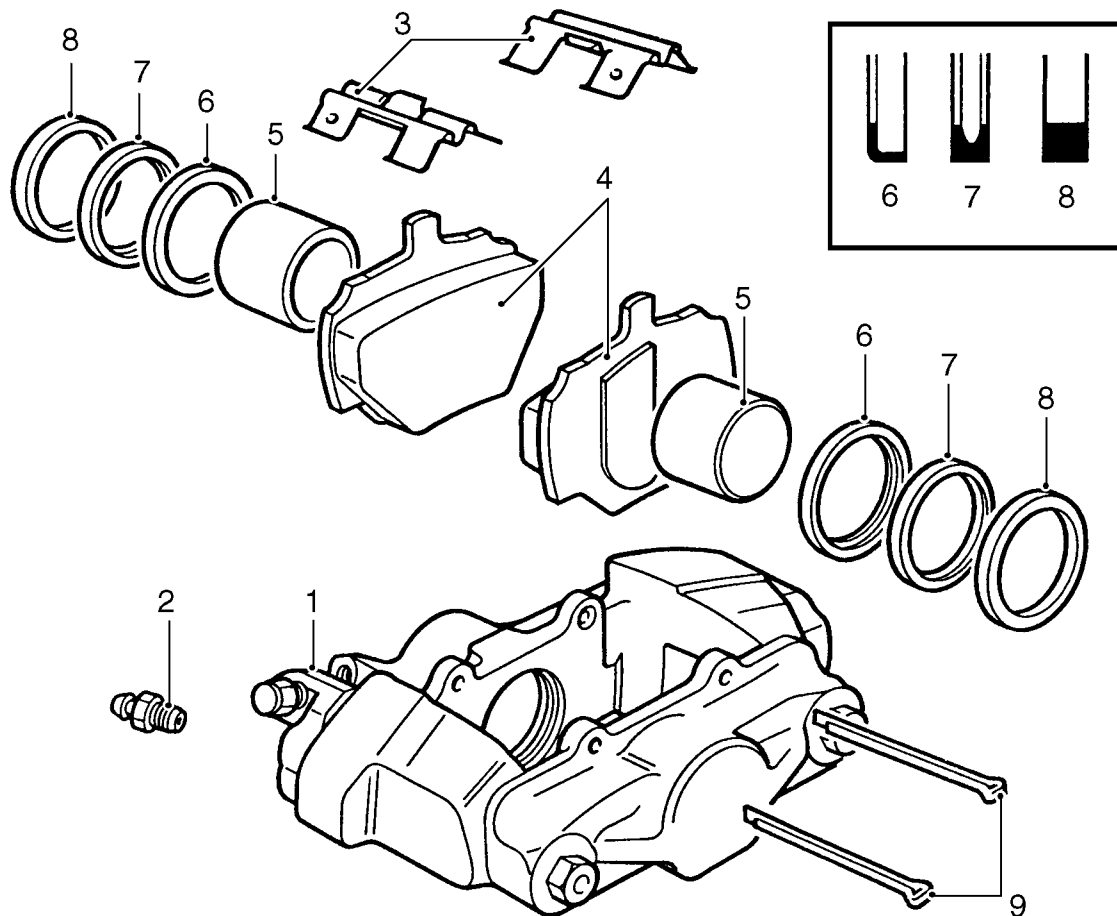

J6335

Key to rear caliper

- | | |
|--------------------------|------------------------|
| 1. Caliper | 6. Wiper seal retainer |
| 2. Bleed screw | 7. Wiper seal |
| 3. Pad retaining springs | 8. Fluid seal |
| 4. Brake pads | 9. Retaining pins |
| 5. Piston | |



REAR BRAKE CALIPERS

Service repair no - 70.55.06

Service repair no - 70.55.17

Before starting repair refer to General brake service practice. **See General Brake Service Practice**

Remove

1. Remove rear road wheels.
2. Using a recognised hose clamp, clamp flexible brake hose above rear axle.

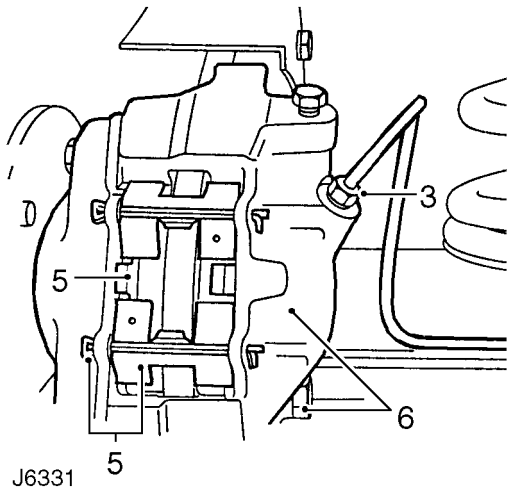

3. Remove brake pipe from rear brake caliper.
4. Seal pipe ends to prevent ingress of dirt.
5. Remove retaining pins and withdraw pads. If same pads are to be refitted, identify them for assembly in original positions.
6. Remove 2 bolts and withdraw caliper from rear axle.

Refit



WARNING: Do not separate caliper halves.

7. Clean outer surfaces of caliper with aerosol brake cleaner.
8. **WITH CAUTION** expel pistons from their bores by applying air pressure to fluid inlet port. It is unlikely both pistons will expel at same time, regulate rate with a suitable piece of wood inserted between two pistons.

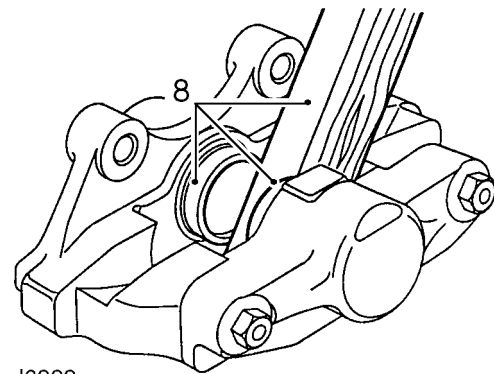

9. Finally, remove pistons keeping them identified with their respective bores.
10. Remove wiper seal retainer by inserting a blunt screwdriver between retainer and seal and pry retainer carefully from mouth of bore.
11. Taking care not to damage seal grooves, extract wiper seal and fluid seal.
12. Clean bores, pistons and particularly seal grooves using clean brake fluid only. If caliper or pistons are corroded or their condition is not perfect new parts must be fitted.
13. Apply brake fluid to new seal. Fit seal into groove in bore. When seal is seated it feels raised to touch at edge furthest away from mouth of bore.

14. Coat piston with brake fluid. Insert it squarely into bore. Do not tilt piston during insertion and leave 8mm, 0.2 in projecting from bore.
15. Coat a new wiper seal with brake fluid and fit to new seal retainer. Slide assembly, seal first, over protruding piston into bore recess.
16. Using special tool **LRT-70-500**- piston clamp, press home seal retainer and piston.

Mounting inboard piston

17. Carry out same procedure as for removing and fitting outboard piston and seals, instructions 8 to 16.

Fit calipers and pads to vehicle

18. Fit caliper to axle, tighten bolts evenly to **82 Nm, 60 lbf ft.**
19. Connect brake pipe to caliper. Tighten to **15 Nm, 11 lbf ft.**
20. Remove clamp from flexible brake hose.

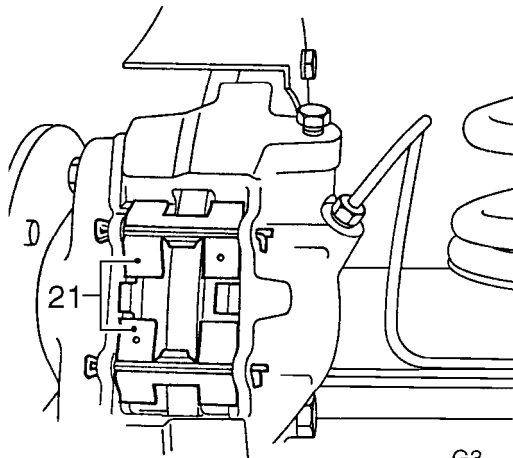

21. Insert pads and retaining springs, secure in position with new retaining pins and spread ends. Ensure retaining springs are located correctly.
22. Bleed brake system. **See Brake System Bleed**
23. Press brake pedal firmly several times to locate pads.
24. Fit road wheels, remove axle stands and finally tighten road wheel nuts, **130 Nm, 95 lbf ft.**
25. Road test vehicle.



CAUTION: New brake pads require 'bedding-in', for several hundred miles before brakes are at maximum efficiency.

REAR BRAKE DISC

Service repair no - 70.10.11.

Remove

1. Remove rear hub assembly. **See REAR AXLE AND FINAL DRIVE, Repair, Rear hub assembly.**

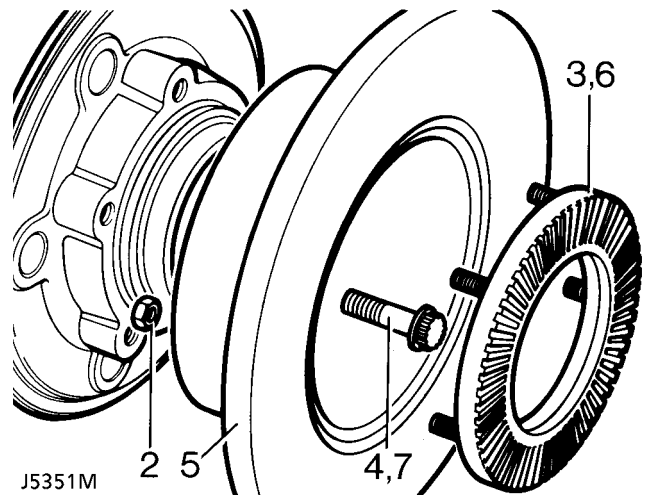

2. Remove 5 nyloc nuts securing road speed sensor ring to disc.
3. Remove sensor ring.
4. Remove disc bolts.
5. Remove disc from rear hub.

Refit

6. Fit disc to rear hub.
7. Apply loctite 270 and fit disc bolts. Tighten to **73 Nm, 54 lbf ft.**
8. Using new nyloc nuts fit sensor ring.
9. Check total disc run out, this must not exceed 0,15 mm, 0.006 in. If necessary reposition disc.
10. Fit rear hub assembly. **See REAR AXLE AND FINAL DRIVE, Repair, Rear Hub Assembly.**

Disc reclamation

11. Check disc thickness. The disc may be machined to minimum thickness of 12 mm, 0.472 in. Machine equal amounts off each face.



NOTE: The brake disc **MUST BE** renewed if the minimum running thickness stamped on the disc is recorded.

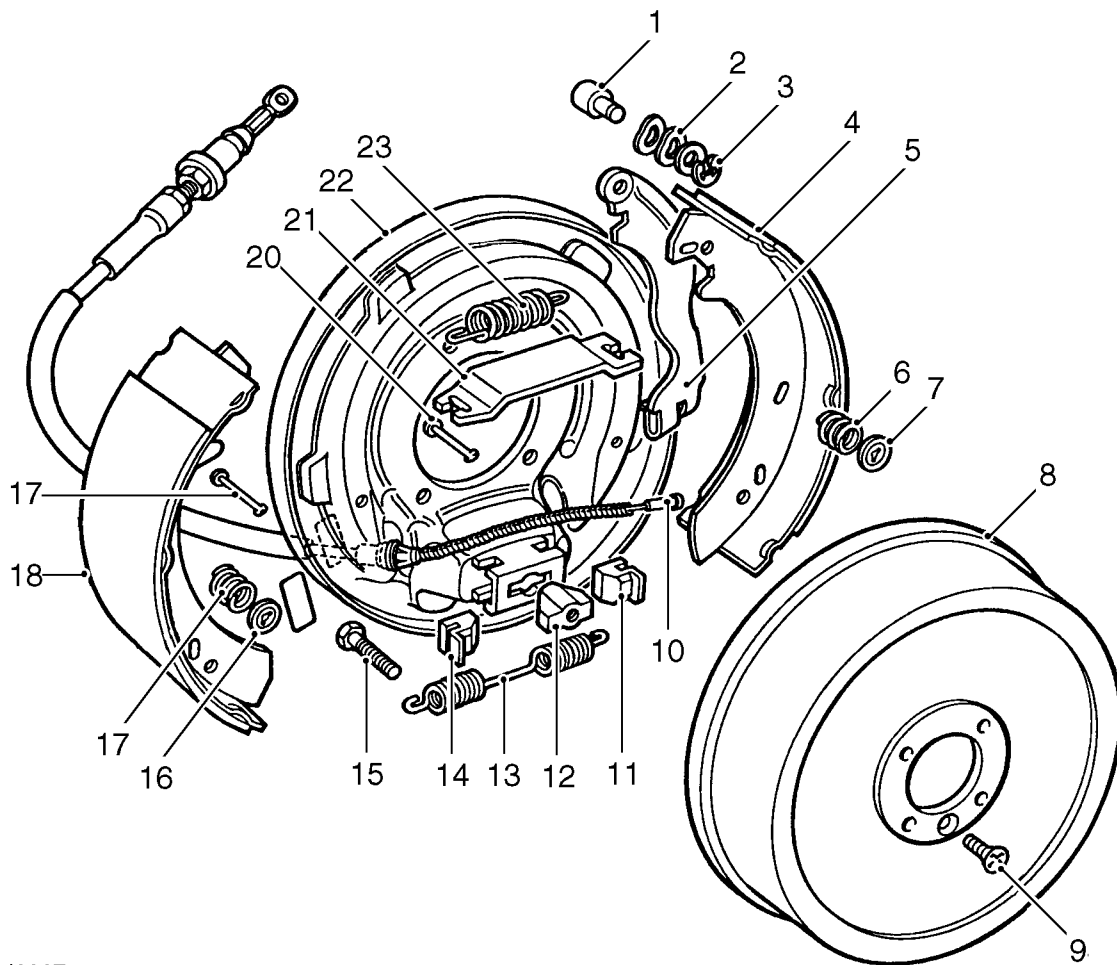

J6337

TRANSMISSION BRAKE

- | | |
|---------------------|----------------------|
| 1. Pin | 13. Spring |
| 2. Washer | 14. Adjuster slide |
| 3. 'C' clip | 15. Adjuster bolt |
| 4. Brake shoe | 16. Dished washer |
| 5. Cable lever | 17. Hold down spring |
| 6. Hold down spring | 18. Brake shoe |
| 7. Dished washer | 19. Hold down pin |
| 8. Brake drum | 20. Hold down pin |
| 9. Screw | 21. Abutment plate |
| 10. Brake cable | 22. Back plate |
| 11. Adjuster slide | 23. Spring |
| 12. Adjuster nut | |

TRANSMISSION BRAKE SHOES

Service repair no - 70.45.18

Remove

1. Park vehicle on level ground, chock road wheels and release park brake. Alternatively, raise vehicle on a ramp.
2. Disconnect rear propeller shaft from transmission output flange at brake drum.
3. Slacken off transmission brake drum adjustment bolt.

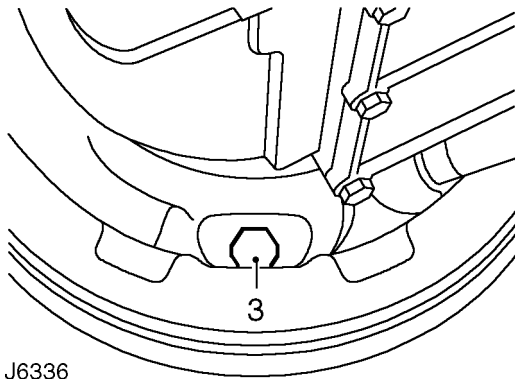

4. Remove single screw securing brake drum to output flange.
5. Withdraw drum to expose brake assembly.
6. Release top and bottom springs from brake shoes.
7. Grip dished washer with a pair of pliers, depress washer and turn through 90 °.
8. Remove dished washer, complete with hold down spring and pin from both shoes.
9. Move brake shoes out from adjuster slides, release from abutment plate and remove from backplate.
10. Check that springs are satisfactory for continued use.



NOTE: If new brake shoes are to be fitted, the springs should also be renewed.

Refit

11. Locate RH brake shoe in slide and secure brake shoe and lever assembly to backplate with hold down pin, spring and dished washer.
12. Locate LH brake shoe in slide and fit abutment plate between both brake shoes. Secure LH shoe with hold down pin, spring and dished washer.
13. Fit pull-off springs to brake shoes.
14. Fit brake drum. Tighten screw to **25 Nm, 18 lbf ft.**
15. Check that park brake lever is released.
16. Screw in and tighten adjuster bolt until brake drum will not rotate by hand.
17. Tighten adjuster bolt to **25 Nm, 18 lbf ft** to ensure brake drum is locked.
18. Slacken off adjuster bolt by 1... turns to give shoes a running clearance. Check that the drum is free to rotate.
19. Fit propeller shaft to output flange. Tighten fixings to **46 Nm, 34 lbf ft.**
20. Remove wheel chocks and check operation of park brake.



PARK BRAKE CABLE

Service repair no - 70.35.25

Remove

1. Park vehicle on level ground, chock road wheels and release handbrake. Alternatively, raise vehicle on ramp [hoist].

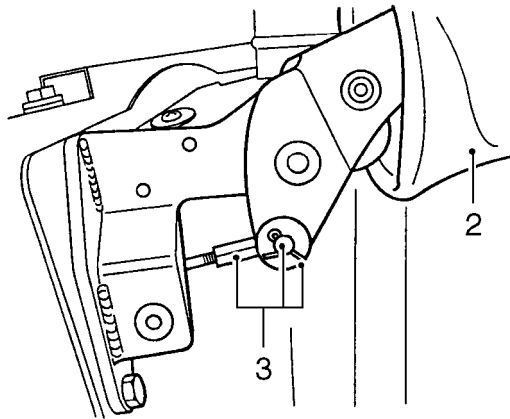

J6338

2. From inside vehicle, pull up handbrake gaiter.
3. Remove split [cotter] pin, clevis pin, washer and disconnect cable from park brake lever.
4. Slacken off transmission brake drum adjusting screw.
5. Disconnect propeller shaft from output flange.
6. Remove retaining screw and withdraw brake drum.
7. Release park brake cable clevis from abutment on cable lever, see J6337, and pull through aperture in back plate.
8. Pull cable from heelboard and remove from vehicle.

Refit

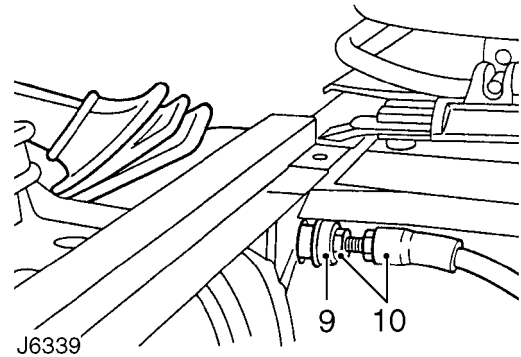

J6339

9. Feed new cable through heelboard ensuring rubber grommet is correctly located.
10. Position cable over guide plate, insert through backplate and connect to cable lever.
11. Fit cable to park brake lever and secure with clevis pin and split [cotter] pin.
12. Fit brake drum. Tighten screw to **25 Nm, 18 lbf ft.**
13. Screw in and tighten adjuster bolt until brake drum will not rotate by hand.
14. Tighten adjuster bolt further to **25 Nm, 18 lbf ft** to ensure brake drum is locked.
15. Slacken off adjuster bolt by 1... turns to give brake shoes running clearance. Check that the drum is free to rotate.
16. Slacken locknut and adjust cable to give the park brake pawl 2 notches free movement on the ratchet before being fully operational on 3rd notch (brake shoes are fully expanded against drum).



NOTE: Cable adjustment is for a new cable or to compensate for cable stretch. Cable adjustment must not be used to take up brake shoe wear.

17. Fit propeller shaft to output flange. Tighten fixings to **46 Nm, 34 lbf ft.**
18. Remove wheel chocks and check operation of handbrake.

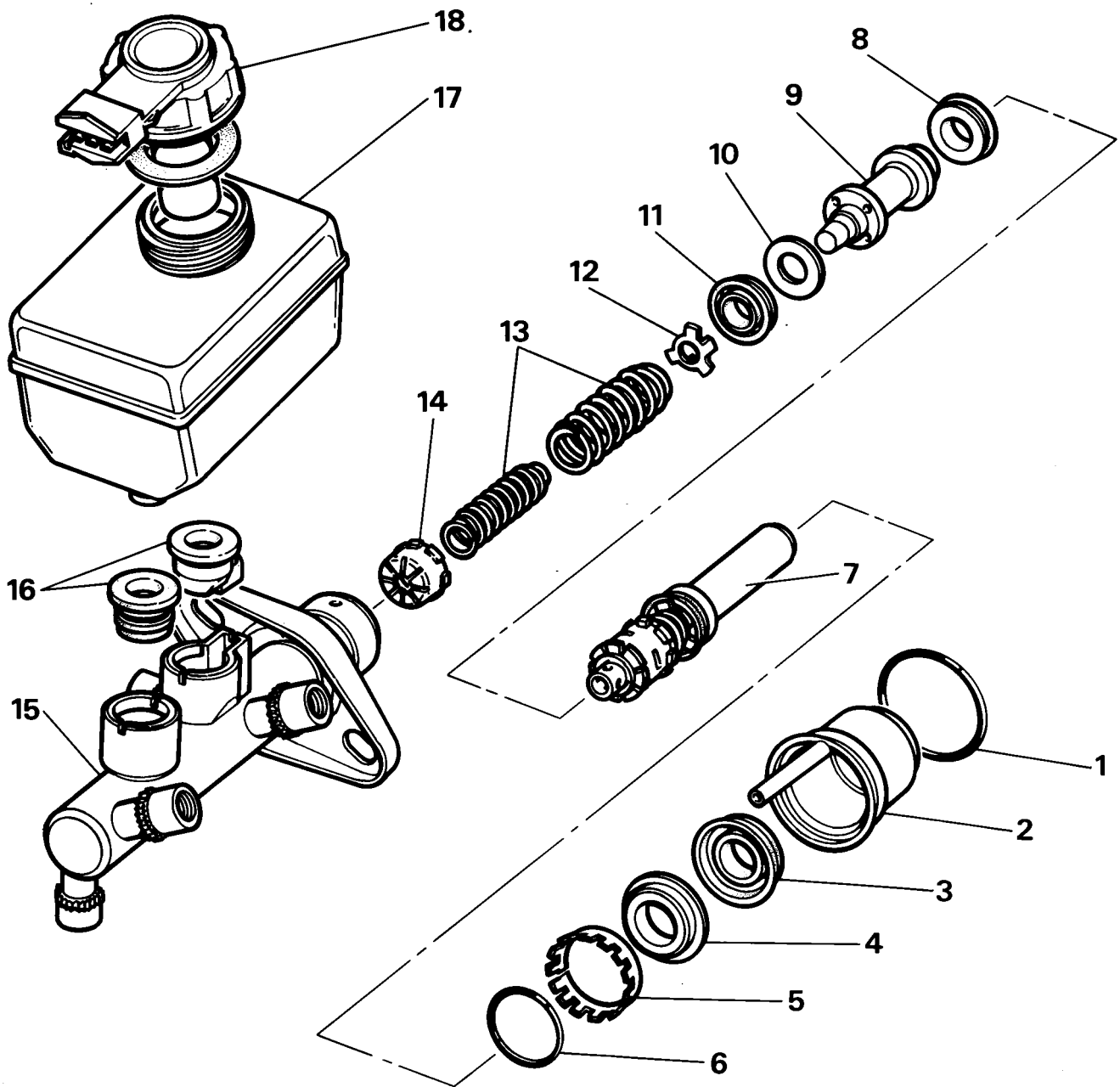

ST3324M

Key to master cylinder

- | | |
|-----------------------------|-------------------------------------|
| 1. Water ingress seal | 10. Washer |
| 2. Transfer housing | 11. Recuperating seal - primary cup |
| 3. Vacuum seal | 12. Seal retainer |
| 4. Guide ring | 13. Springs - 2 off |
| 5. Retaining ring | 14. Swirl tube |
| 6. 'O' ring seal | 15. Master cylinder body |
| 7. Primary plunger assembly | 16. Reservoir seals |
| 8. 'L' seal | 17. Reservoir |
| 9. Secondary plunger | 18. Low fluid level switch and cap |

MASTER CYLINDER

Service repair no - 70.30.09

Before starting overhaul procedure refer to general brake service practice. **See Repair, General brake service practice**

Dismantling master cylinder

1. Disconnect battery and remove master cylinder from servo **See Repair, Master cylinder**
2. Before commencing overhaul procedure thoroughly clean master cylinder and inspect outer surfaces for damage and condition, renew complete assembly if necessary.

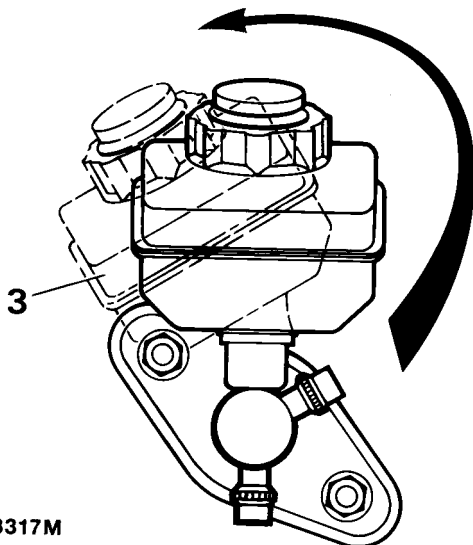

ST3317M

3. The reservoir is a push fit in master cylinder and secured by seals. Carefully ease reservoir from master cylinder by rolling it from seals as illustrated.
4. Using soft jaws, one either side of master cylinder flange and clamp flange in a suitable vice. Remove water ingress 'O' ring seal from master cylinder to servo flange and discard.

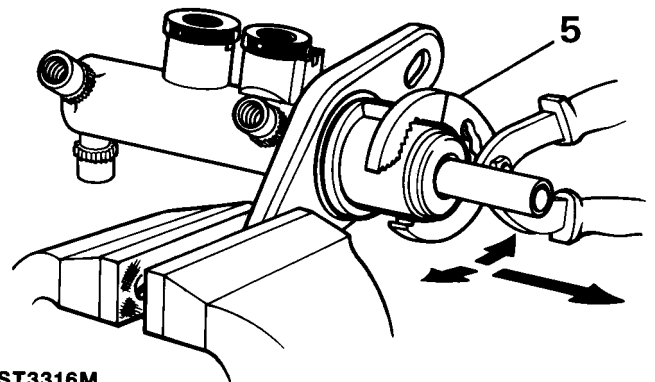

ST3316M

5. Hold outside of transfer housing with a suitable pair of grips, carefully pull, while working pliers in a backwards and forwards rocking motion to ease housing off master cylinder, discard housing and vacuum seal.

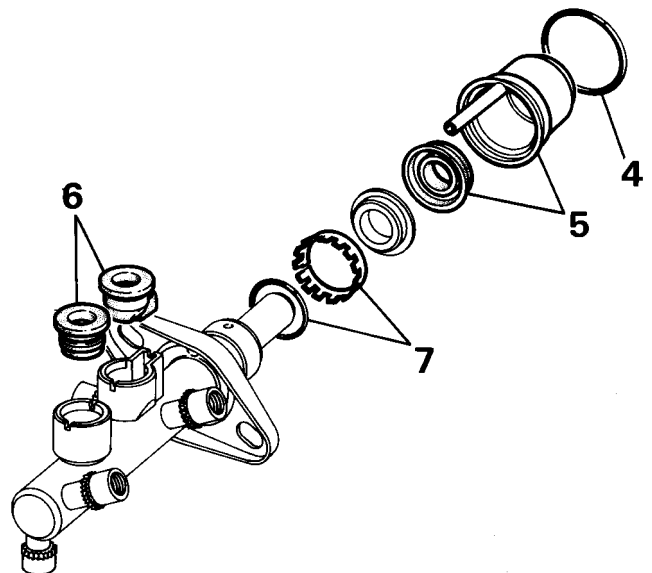

ST3318M

6. Withdraw 2 reservoir seals from master cylinder inlet ports, seals are different and should be noted for assembly. Discard both seals.
7. Remove retaining ring and 'O' ring seal from machined outer surface of master cylinder, discard both seal and retaining ring.

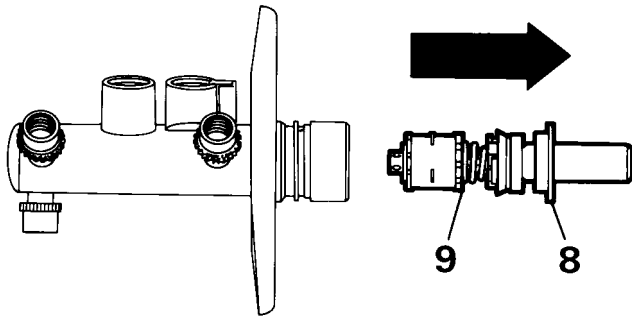

ST3319M

8. Remove guide ring from mouth of master cylinder which supports primary plunger assembly and place to one side, this component is not part of master cylinder service kit and is to be refitted on assembly of unit.
9. Pull primary plunger assembly out of master cylinder.

NOTE: The primary plunger assembly cannot be broken down any further and is serviced as a complete unit. Discard assembly.

10. The secondary plunger assembly will remain at bottom of master cylinder bore, plunger can be easily expelled by tapping assembly on a piece of timber until plunger appears at cylinder mouth, carefully pull plunger out of master cylinder.

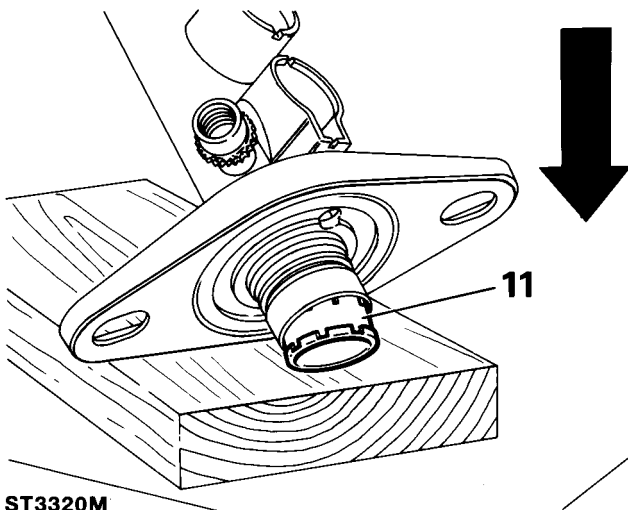

ST3320M

11. If swirl tube was not expelled at same time as secondary plunger, repeat above operation to expel it from bottom of master cylinder bore and discard.

12. Clean all parts with Girling cleaning fluid or unused brake fluid and place cleaned parts on to a clean sheet of paper. Inspect cylinder bore and plungers for signs of corrosion, ridges and score marks. Provided working surfaces are in perfect condition, new seals from a Girling Service repair kit may be used.

Renewing secondary plunger seals

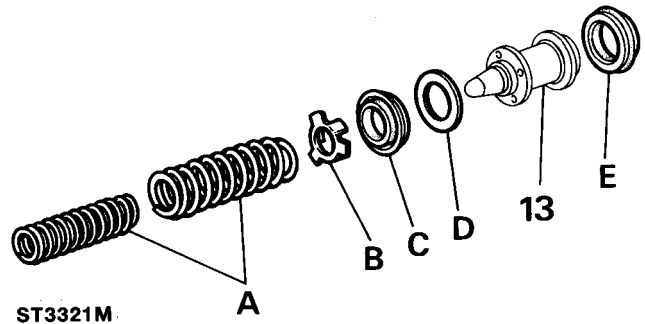

ST3321M

13. Remove following components from secondary plunger and discard:

NOTE: A small screwdriver with end rounded and polished is required to remove 'L' seal. DO NOT damage secondary plunger. A. Springs B. Seal retainer C. Recuperating seal (primary cup) D. Washer E. 'L' seal

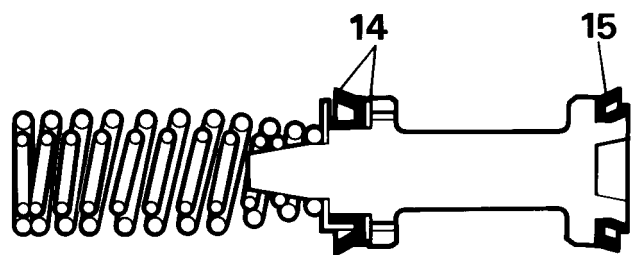

ST3322M

14. Coat new seals in unused brake fluid and firstly fit 'L' seal to plunger.
15. Fit washer followed by recuperating seal. Fit seal retainer and springs, ensure springs are correctly seated.

Assembling master cylinder



CAUTION: It is important that the following instructions are carried out precisely, otherwise damage could be caused to new seals when inserting plungers into cylinder bore. Generous amounts of new brake fluid should be used to lubricate parts during assembly.



NOTE: Thoroughly check that no debris is lodged in fluid passageways and drillings. If debris is found, carefully remove, re-clean cylinder and re-check.

16. Fit new swirl tube to bottom of cylinder bore.

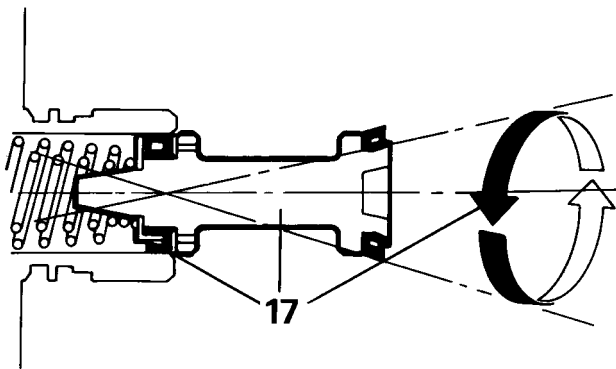

ST3323M

17. Lubricate secondary plunger and cylinder bore. Offer plunger assembly to cylinder until recuperation seal is resting centrally in mouth of bore. Gently introduce plunger with a circular rocking motion, as illustrated. Ensuring that seal does not become trapped, ease seal into bore and slowly push plunger down bore in one continuous movement.
18. Fit primary plunger assembly using same method as for secondary plunger, push plunger down bore.
19. Fit original guide ring to support primary plunger.
20. Coat a new 'O' ring with brake fluid and fit to its respective groove on outer location surface of master cylinder.



CAUTION: 'O' ring should not be rolled down outer location surface of master cylinder but should be slightly stretched and eased down cylinder and into its groove. Do not over stretch seal.

21. Fit a new retaining ring on outer surface of master cylinder ensuring that serrations of ring are facing mounting flange.
22. Fit two new reservoir seals in its respective ports.
23. Fit a new vacuum seal to either primary plunger or to bottom of transfer housing bore, open face of seal towards primary plunger guide ring.
24. Lubricate vacuum seal with brake fluid, fit transfer housing to master cylinder, push housing fully up to cylinder mounting flange. Do not adjust transfer housing after fitting.
25. Lubricate a new water ingress seal with brake fluid, slightly stretch seal and ease it down housing until seal is in correct position between housing and flange.
26. Roll reservoir into top of master cylinder, reversing procedure described in instruction 3.
27. Fit master cylinder to servo. **See Repair, Master cylinder**
28. Reconnect battery, and road test vehicle.



TORQUE VALUES

Brakes	Nm	lbf ft
Brake pipe connections to:		
- Pressure reducing valve	15	11
- Brake calipers	15	11
- Master cylinder	15	11
Flexible hoses to calipers	15	11
Bleed screws	15	11
Brake caliper to swivel pin housing	82	60
Brake disc bolts*	73	54
Brake drum screw	25	18
Rear propeller shaft flange	46	34
Brake drum adjuster bolt	25	18
Servo assembly to pedal box	26	19
Pedal box to engine bulkhead	25	18
Master cylinder to servo	26	19
Road wheels	130	95

* Apply Loctite 270 before assembly



TYPES OF WHEEL RIMS AND TYRES

Description

The vehicle is equipped with alloy wheels and tubeless radial ply tyres.

Tyre codes

The writing, codes and numbers moulded into the tyre wall vary between tyre manufacturers, however most tyres are marked with the information shown in the illustrated example.

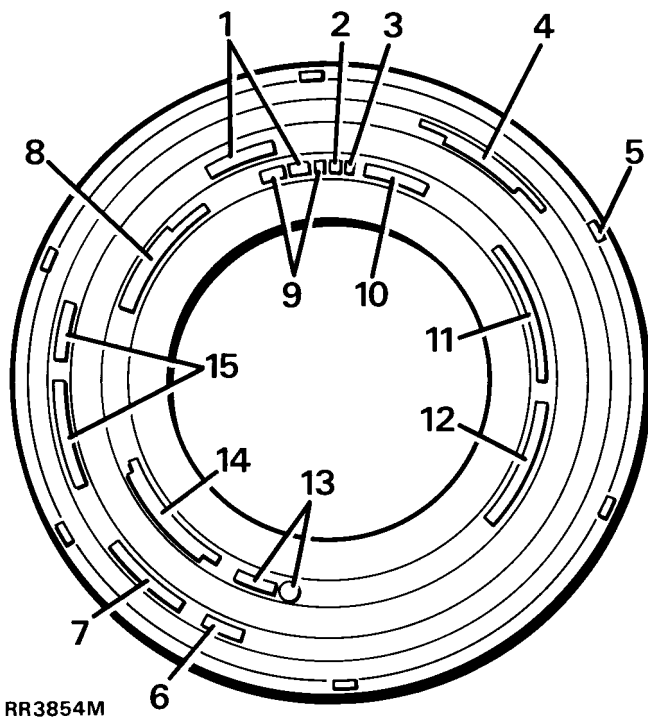



1. Type of tyre construction - **Radial Ply**
2. Load index - **104**
3. Speed symbol - **S or T**
4. USA Tyre quality grading - **Tread wear 160 Traction A temperature B**
5. Tread wear indicators moulded into tread pattern are located at intervals around the tyre and marked by a code - **E66 103S6**
6. Tyres with 'Mud Snow' type tread pattern are marked - **M&S**
7. Tyre reinforcing mark - **Reinforced**
8. USA Load and pressure specification - **1260Kg(2778LBS) at 450kPa (65psi)**
9. Tyre size - **265/75 R16 All Terrain**
10. Type of tyre - **TUBELESS**
11. Country of manufacture - **MADE IN GREAT BRITAIN**
12. USA Compliance symbol and identification - **DOT AB7C DOFF 267**
13. European type approval identification - **E11 01234**
14. Tyre construction - **SIDE WALL 2 PLYS RAYON. TREAD 2 RAYON 2 STEEL**
15. Manufacturers brand name/type - **TRACTION PLUS mzx M**

 **NOTE:** The illustration is an example of the type of markings moulded into tyres and is for guidance only. For specific tyre specifications See **GENERAL SPECIFICATION DATA, Information, Tyre size and pressures** .

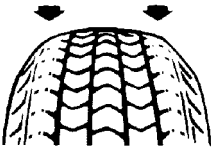
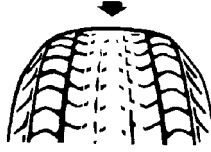
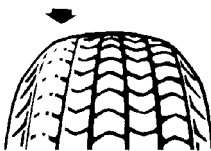

TYRE WEAR CHART

FAULT	CAUSE	REMEDY
<p>Rapid wear at shoulders</p> 	<p>Tyres under-inflated Worn suspension components i.e. ball joints, panhard rod bushes, steering damper</p> <p>Excessive cornering speeds</p>	<p>Inflate to correct pressure Replace worn components</p>
<p>Rapid wear at centre of tread</p> 	<p>Tyres over-inflated</p>	<p>Inflate to correct pressure</p>
<p>Wear at one shoulder</p> 	<p>Track out of adjustment</p> <p>Bent panhard rod</p>	<p>Adjust track to correct figure</p> <p>Check and replace worn or damaged components</p>
<p>Bald spots or tyre cupping</p> 	<p>Wheel out of balance</p> <p>Excessive radial runout</p> <p>Shock absorber worn</p> <p>Excessive braking</p>	<p>Balance wheel and tyre assembly</p> <p>Check runout and replace tyre if necessary</p> <p>Replace shock absorber</p>
<p>Tyre scalloped</p>  <p>RR2136E</p>	<p>Track out of adjustment</p> <p>Worn suspension components</p> <p>Excessive cornering speeds</p>	<p>Adjust toe to correct figure</p> <p>Replace as necessary</p>



CAUTION: This diagnosis chart is for general guidance only and does not necessarily include every cause of abnormal tyre wear.

FAULT - SYMPTOMS

Vibration through steering wheel

1. Check tyre pressures. *See Repair, Tyre Pressures*
2. Check condition of tyres. *See Tyre Wear Chart*
3. Check front wheel alignment *See STEERING, Adjustment, Front Wheel Alignment*
4. Check wheel balance. *See Repair, Wheel Balancing*



NOTE: In the event that any apparent vibration is not eliminated at this stage. *See PROPELLER SHAFTS, Fault diagnosis, Vibration Harshness*



NOTE: Radial ply tyres have a flexible sidewall, which produces a sidewall bulge making the tyre appear under-inflated. This is a normal condition for radial ply tyres. Do not attempt to reduce this bulge by over-inflating the tyre.

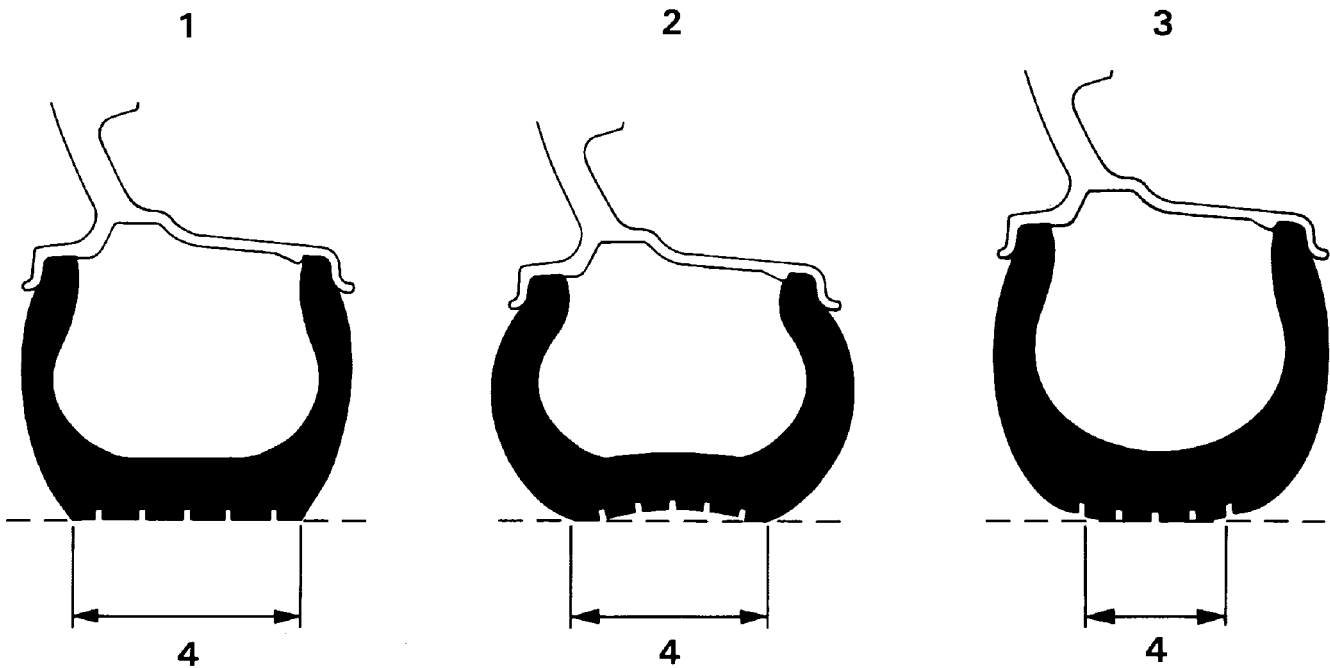

RR2133E

1. Correct inflation.
2. Under-inflation.
3. Over-inflation.
4. Tread contact with road.



GENERAL INFORMATION



WARNING: This is a multi-purpose vehicle with wheels and tyres designed for both on and off road usage. Only use wheels and tyres specified for use on the vehicle.

The vehicle is equipped with tubeless radial ply tyres as standard equipment. The tyres are of European metric size and must not be confused with the 'P' size metric tyres available in North America.

Vehicle wheel sets, including spare wheel, must be fitted with the same make and type of tyre to the correct specification and tread pattern. Under no circumstances must cross-ply or bias-belted tyres be used.

For tyre specification and pressures. **See GENERAL SPECIFICATION DATA, Information, Wheels and Tyres**

Alloy Wheels

Tubeless tyres are mounted on 7.0 inch wide by 16 inch diameter cast aluminium alloy wheels. The surface has a paint finish covered with a clear polyurethane lacquer. Care must be taken when handling the wheel to avoid scratching or chipping the finish.

The alloy wheel rim is of the asymmetric hump type incorporating a safety hump to improve location of the tyre bead in its seat. If difficulty is experienced in fitting tyres to this type of rim. See Tyre Fitting



WARNING: DO NOT fit an inner tube to an alloy wheel.

TYRE INSPECTION

Inspect tyres at weekly intervals to obtain maximum tyre life and performance and to ensure compliance with legal requirements. Check for signs of incorrect inflation and uneven wear, which may indicate a need for balancing or front wheel alignment, if the tyres have abnormal or uneven wear patterns. **See Fault diagnosis, Tyre Wear Chart**

Check tyres at least weekly for cuts, abrasions, bulges and for objects embedded in the tread. More frequent inspections are recommended when the vehicle is regularly used in off road conditions.

To assist tyre inspection, tread wear indicators are moulded into the bottom of the tread grooves, as shown in the illustration below.

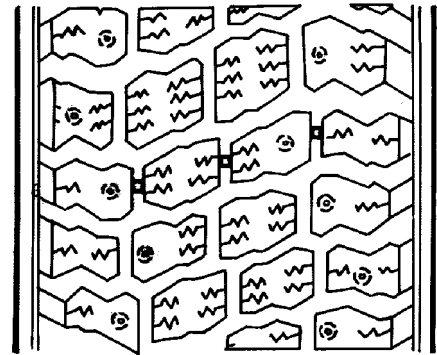

RR2145E

When the tread has worn to a remaining depth of 1.6 mm, 0.06 in the indicators appear at the surface as bars which connect the tread pattern across the width of the tread as shown in the illustration below.

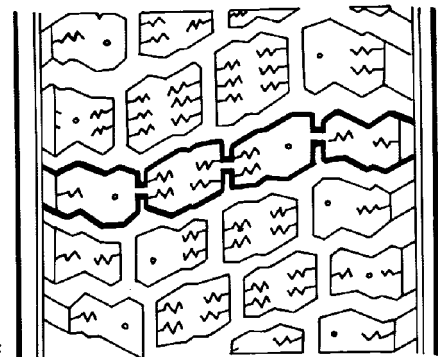

RR2146E

When the indicators appear in 2 or more adjacent grooves, at 3 locations around the tyre, a new tyre must be fitted.



NOTE: DO NOT attempt to interchange tyres, e.g. from front to rear, as tyre wear produces characteristic patterns depending on their position. If tyre position is changed after wear has occurred, the performance of the tyre will be adversely affected.



NOTE: Territorial vehicle regulations governing tyre wear MUST be adhered to.

WHEELS INSPECTION

Regularly check the condition of the wheels. Replace any wheel that is bent, cracked, dented or has excessive runout.

VALVES INSPECTION

Check condition of inflation valve. Replace any valve that is worn, cracked, loose, or leaking air.

TYRE PRESSURES

Maximum tyre life and performance will be obtained only if tyres are maintained at the correct pressures .

Tyre pressures must be checked at least once a week and preferably daily, if the vehicle is used off road.

The tyre inflation pressure is calculated to give the vehicle satisfactory ride and steering characteristics without compromising tyre tread life. For recommended tyre pressures in all conditions **See GENERAL SPECIFICATION DATA, Information, Wheels and Tyres**

Always check tyre inflation pressures using an accurate gauge and inflate tyres to the recommended pressures only .

Check and adjust tyre pressures **ONLY** when the tyres are cold, vehicle parked for three hours or more, or driven for less than 3 km, 2 miles at speeds below 65 km/h, 40 mph. Do not reduce inflation pressures if the tyres are hot or the vehicle has been driven for more than 3 km, 2 miles at speeds over 65 km/h, 40 mph, as pressures can increase by 0.4 bar, 6 lb/in² over cold inflation pressures.

Check **ALL** tyre pressures including the spare. Refit the valve caps as they form a positive seal and keep dust out of the valve.

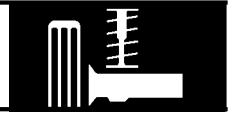

WHEEL BALANCING



CAUTION: It is essential that all wheel balancing is carried out off the vehicle. The use of on the vehicle balancing could cause component damage or personal injury and **MUST NOT** be attempted.



NOTE: Before attempting to balance a wheel and tyre assembly clean all mud and dirt deposits from both inside and outside rims and remove existing balance weights.

Remove stones from the tyre tread in order to avoid operator injury during dynamic balancing and to obtain the correct balance.

Inspect tyres for damage and correct tyre pressures and balance according to the equipment manufacturer's instructions.

Alloy wheels

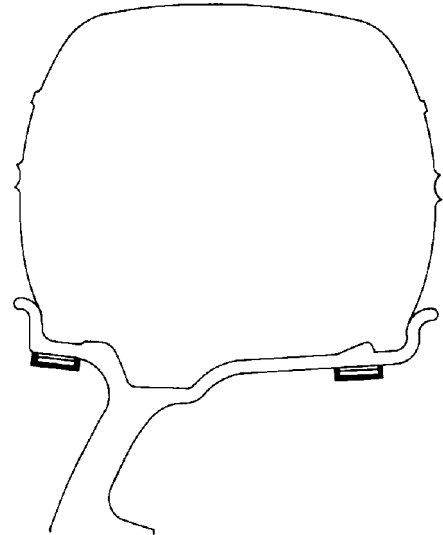

RR2 138E

Clean area of wheel rim and attach adhesive balance weights in position shown. Cut through rear face of weight strip to detach required weights.

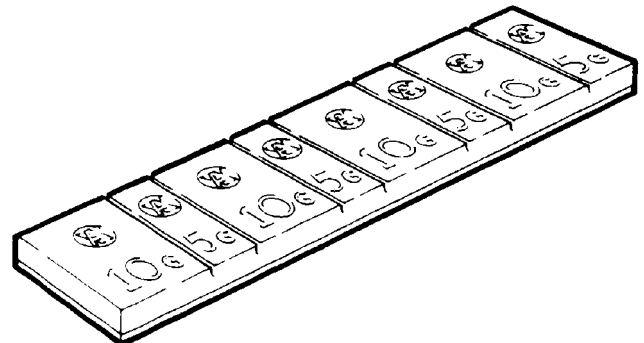

RR2 137E



CAUTION: Use only correct adhesive balance weights to avoid damage to aluminium wheel rim. **DO NOT** attempt to use a steel wheel weight on an aluminium wheel.

Static balance

Wheel tramp

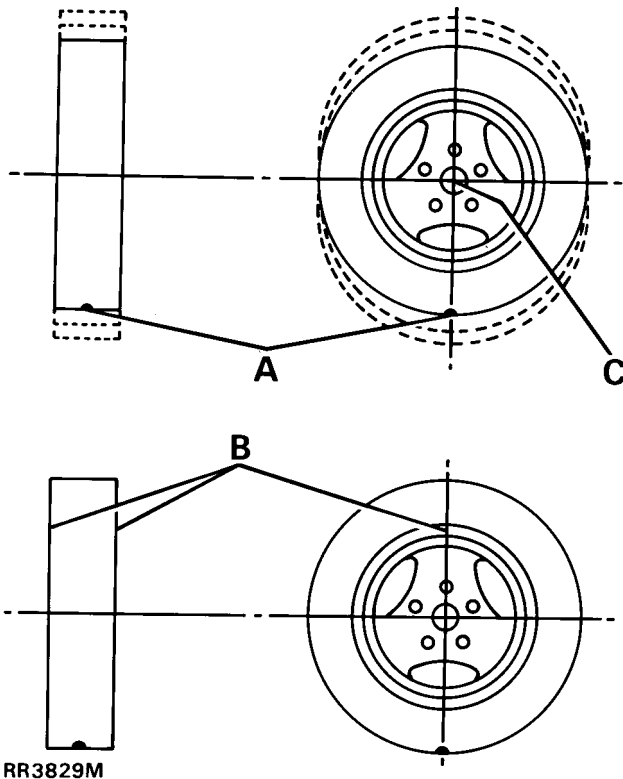

RR3829M

- A. Heavy spot.
- B. Add balance weights here.
- C. Centre line of spindle.

Static balance is the equal distribution of weight around the wheel. A statically unbalanced wheel will cause a bouncing action called wheel tramp. This condition will eventually cause uneven tyre wear.

Dynamic balance

Wheel shimmy

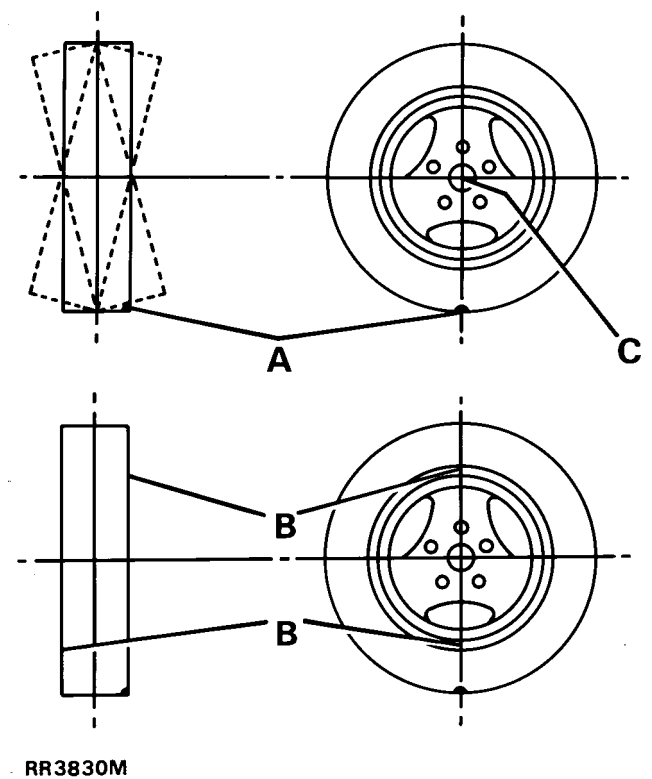

RR3830M

- A. Heavy spot.
- B. Add balance weights here.
- C. Centre line of spindle.

Dynamic balance is the equal distribution of weight on each side of the centre line so that when the wheel spins there is no tendency for side to side movement. A dynamically unbalanced wheel will cause wheel shimmy.

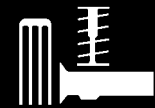

Off vehicle balancing

Balance wheel assembly referring to equipment manufacturer's instructions.

It is essential that the wheel is located by the centre hole **NOT** the stud holes. To ensure positive wheel location the diameter of the locating collar on the machine shaft must be 112.80 to 112.85 mm, 4.441 to 4.443 in. This diameter will ensure that the collar fits correctly within the centre hole of the wheel.

Where possible always use the vehicle wheel retaining nuts to locate the wheel on the balancer, to avoid damaging the wheel. If this is not possible, the locating nuts must be of a similar pattern to the original wheel nuts. The use of conical type wheel nuts for this purpose may damage the surface on alloy wheels.

Cleaning

Wash the aluminium wheels using a suitable wash and wax concentrate correctly diluted and rinse with cold clear water. **DO NOT** use abrasives or aluminium wheel cleaners containing acid, as they will destroy the lacquer finish.

Tyre changing

Use only tyre changing equipment to mount or demount tyres, following the equipment manufacturer's instructions. **DO NOT** use hand tools or tyre levers, as they may damage tyre beads or the wheel rim.

Puncture repair

Remove punctured tyre from wheel and repair using a combination service plug and vulcanising patch. Always follow manufacturer's instructions when using a puncture repair kit.

Only punctures in tread area are repairable, **DO NOT attempt to repair punctures in tyre shoulders or sidewalls.**

Do not attempt to repair a tyre that has sustained the following: bulges or blisters, ply separation, broken or cracked beads, wear indicators visible and punctures larger than 6 mm diameter.



CAUTION: Do not use tyre sealants that are injected through valve stem to repair punctured tyres, they may produce wheel corrosion and tyre imbalance.

Aluminium wheel rim bead seats should be cleaned using a non-abrasive cleaner to remove the mounting lubricants and old rubber. Before mounting or demounting a tyre, bead area should be well lubricated with a suitable tyre lubricant.

TYRE FITTING

Alloy wheels

1. Install a new valve assembly.
2. Ensure wheel and tyre is adequately lubricated.
3. Mount tyre in normal manner. Inflate tyre and at same time apply hand pressure to area around valve to aid seating over valve first.



NOTE: Stop inflation immediately if tyre seats opposite valve, as this will result in valve being blocked by tyre beading, making further inflation impossible, and carry out following procedure.

4. Deflate tyre, unseat and rotate it around the rim until valve is in line with that part of tyre which seated initially. This part of beading having seated over hump previously will automatically seat first when tyre is re-inflated.
5. Inflate tyre to seat beads correctly, finally inflate to correct pressure.

WHEELS

Remove



WARNING: The parking brake acts on the transmission, not rear wheels, and may not hold vehicle when jacking unless the following procedure is used. If one front wheel and one rear wheel is raised, no vehicle holding or braking effect is possible. Wheels **MUST** be chocked in all circumstances.

Apply parking brake, select 'P' in main gearbox and engage low gear in transfer box.

1. Loosen 5 wheel nuts.
2. Using a suitable trolley jack, raise vehicle and place on axle stands. **See INTRODUCTION, Information, Jacking**
3. Remove wheel nuts and carefully withdraw wheel over studs.

Refit

4. Ensure that retaining studs and nuts are clean.
5. Alloy wheels: Lightly coat wheel mounting spigot face with a suitable anti-seize compound to minimise possibility of adhesion between wheel and spigot face.
6. Refit wheel taking care not to damage stud threads. (Do not apply oil).
7. Fit wheel nuts and turn by hand for at least 3 full threads before using any form of wheel wrench.
8. Tighten nuts as much as possible using a suitable wrench.

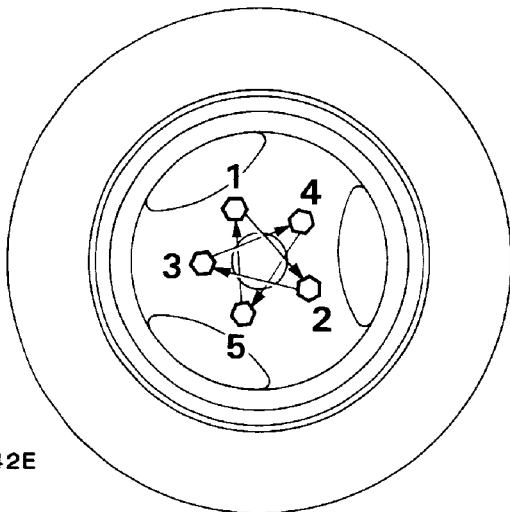

RR2142E

9. Lower vehicle and finally tighten nuts to correct torque in sequence shown. **130 Nm, 95 lbf ft.**

WHEEL STUD

Remove

1. Remove wheel. **See Wheels**
2. Drive stud out of driveshaft flange.

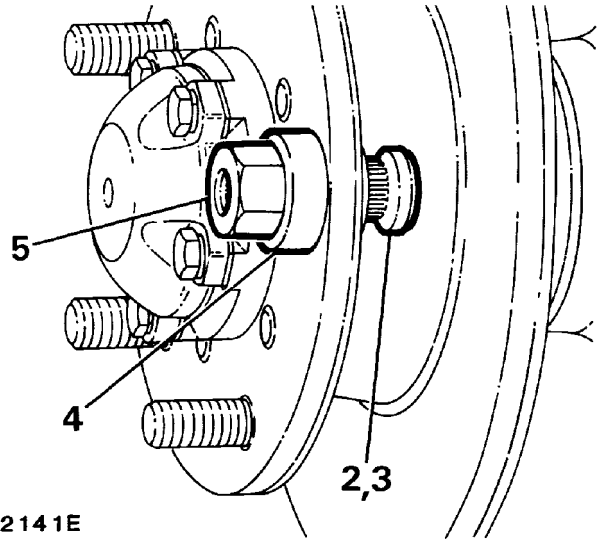

RR2141E

Refit

3. Position stud in flange.
4. Install a suitable spacer over stud.
5. Using a M16 x 1.5 nut, a slave wheel nut is suitable, pull stud into flange until shoulder of stud abuts flange.
6. Refit wheel. **See Wheels**



CHASSIS AND BODY

Chassis

The chassis on all Defender variants are of the box section, ladder type construction, manufactured from 2 mm (14swg) steel and treated with zinc phosphate, cathodic electro coated, followed by waxing in the rear crossmember.

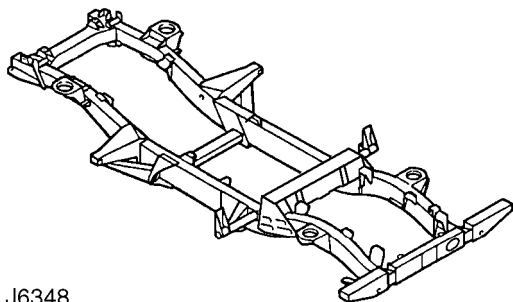

J6348

Outriggers and angled brackets welded to the chassis support suspension and axle components and are also used as body mounting points. A detachable box section crossmember, located between the two chassis longitudinals, is fitted to facilitate main gearbox and transfer box assembly removal.

Should chassis damage occur a comprehensive range of components are available, including body support outriggers, cross members and radius arm mounting brackets. ALWAYS fit genuine parts that are fully guaranteed and to original equipment specification, fitted with Land Rover's BS 5135 welding standard.

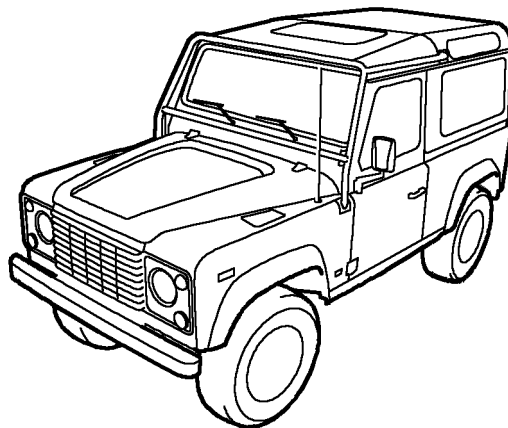

J6350

Body

All body panels, with the exception of the fascia bulkhead, are manufactured from aluminium alloy. Galvanized steel is used for the front wheel arches to give optimum protection. Most panels are also treated with zinc phosphate and cathodic electrocoated with polyester surfacer, and are bolted to the welded chassis.

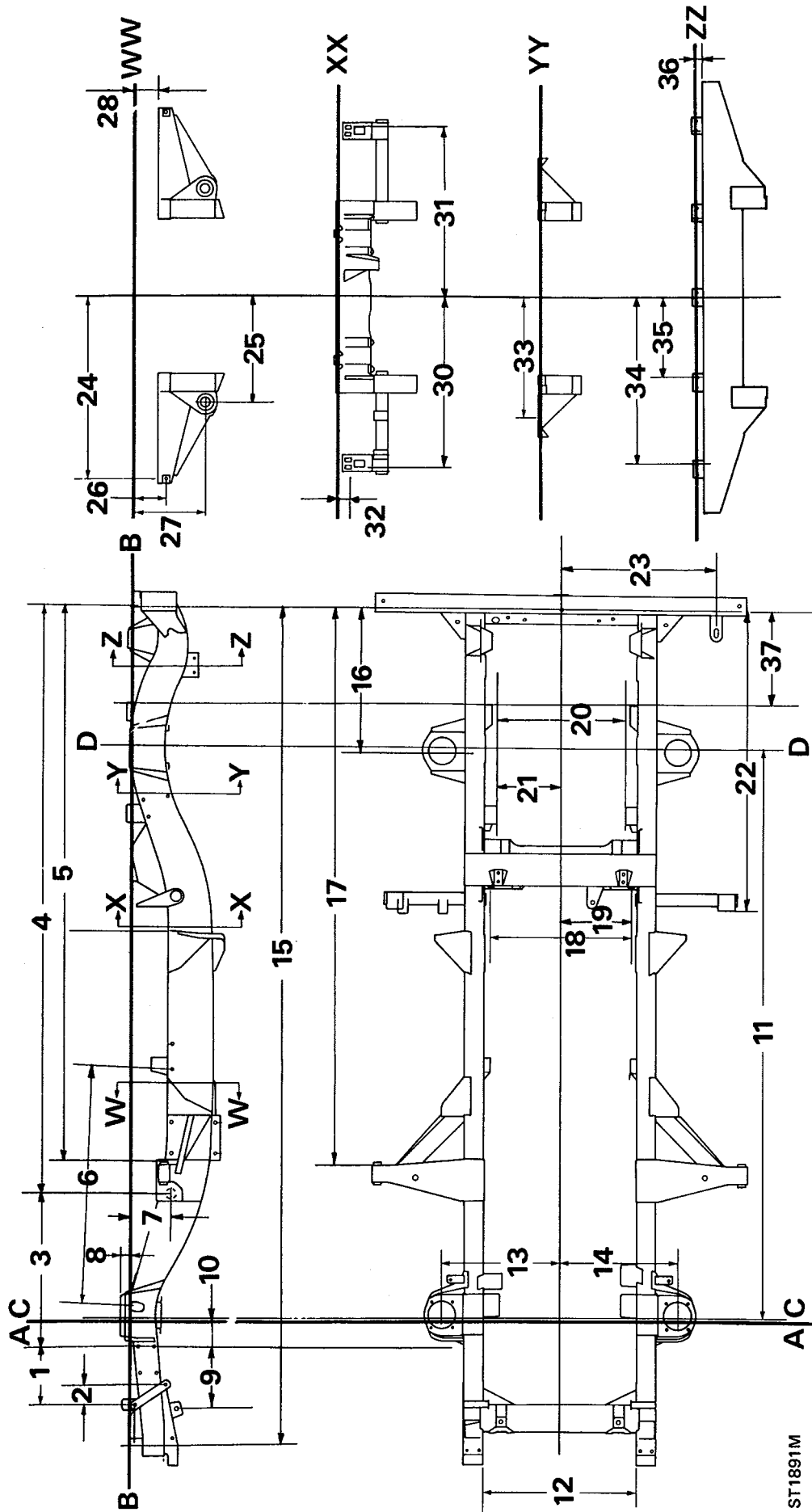

ST1891M



CHASSIS ALIGNMENT DIMENSIONS

- A Front Datum**
B Chassis Datum
C Front axle centre line
D Rear axle centre line

- | | |
|---|---|
| 1. 239,0 - 236,5 mm 9.41 - 9.31 in | 20. 519,60 - 517,00 mm 20.46 - 20.35 in |
| 2. 82,0 - 79,5 mm 3.23 - 3.13 in | 21. 259,80 - 258,50 mm 10.23 - 10.18 in |
| 3. 633 mm 24.921 in | 22. 1242,6 - 1240,6 mm 48.92 - 48.84 in |
| 4. 2420,6 - 2418,6 mm 94.51 - 95.22 in | 23. 642,5 - 639,5 mm 25.30 - 25.18 in |
| 5. 2306,4 - 2305,4 mm 90.80 - 90.76 in | 24. 750,9 mm 29.56 in |
| 6. 981,2 - 978,7 mm 38.63 - 38.53 in | 25. 439,5 - 436,5 mm 17.30 - 17.18 in |
| 7. 182,7 mm 7.19 in | 26. 136,5 mm 5.37 in |
| 8. 41,5 - 37,0 mm 1.63 - 1.46 in | 27. 299,5 - 295,5 mm 11.79 - 11.63 in |
| 9. 252 - 250 mm 9.92 - 9.84 in | 28. 103 - 100 mm 4.06 - 3.94 in |
| 10. 110 mm 4.33 in | 29. 131,5 - 126,5 mm 5.18 - 4.98 in |
| 11. 2360mm - 92.91 in - Wheelbase | 30. 705,5 - 704,5 mm 27.76 - 27.74 in |
| 12. 636 - 634 mm 25.04 - 24.96 in | 31. 705,5 - 704,5 mm 27.76 - 27.74 in |
| 13. 488 - 483 mm 19.21 - 19.01 | 32. 42,2 - 40,2 mm 1.66 - 1.58 in |
| 14. 488 - 483 mm 19.21 - 19.01 in | 33. 491 - 486 mm 19.33 - 19.13 in |
| 15. 3431,1 - 3426,1 mm 135.08 - 134.89 in | 34. 594,2 - 593,4 mm 23.39 - 23.36 in |
| 16. 588,3 - 586,3 mm 23.16 - 23.08 in | 35. 283,0 - 282,2 mm 11.14 - 11.11 in |
| 17. 2313,8 - 2311,8 mm 91.09 - 91.06 in | 36. 32,25 - 31,25 mm 1.27 - 1.23 in |
| 18. 590,5 mm 23.25 in | 37. 397 - 395 mm 15.63 - 15.55 in |
| 19. 295,25 mm 11.62 in | |

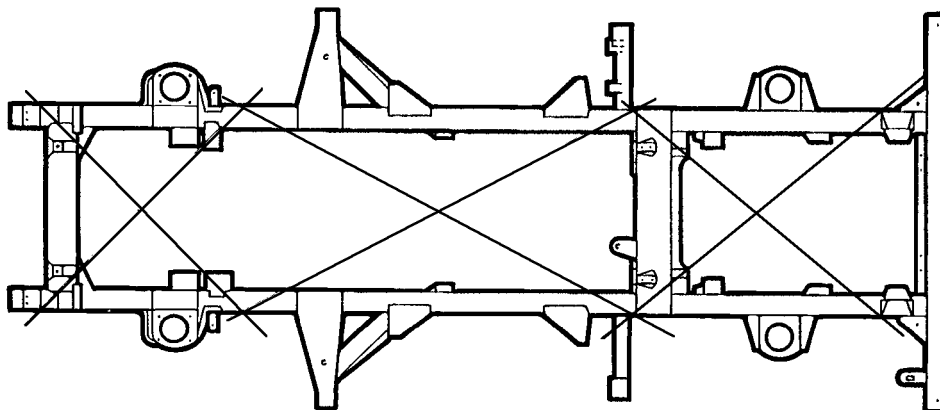

76M2376

Chassis frame alignment

With the vehicle assembled a check for chassis squareness can be made as follows:

1. Place the vehicle on a level floor.
2. Mark measuring points at approximately the locations shown, ensure that the marks are exactly opposite on each side of the chassis frame.
3. Hold a plumb line against each of the measuring points in turn and mark the floor directly beneath the plumb-bob.
4. Move the vehicle and measure diagonally between the marks made on the floor, if the chassis is square the diagonals between the related measuring points should agree within 9,50 mm.
5. Chassis frame dimensional checks can be made, with the vehicle upper structure removed, referring to the applicable illustration and associated key.



DOOR LOCK STRIKER - ADJUST

Service repair no - 76.37.23

Adjust

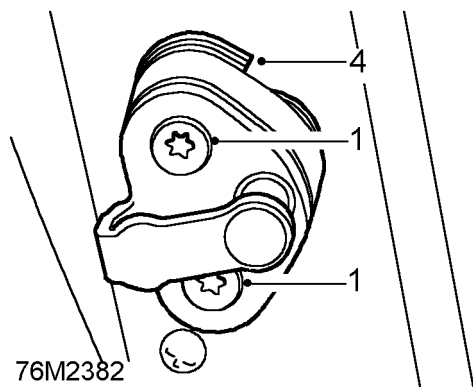

1. Loosen Torx bolts securing striker to 'B' post.
2. Adjust alignment of striker vertically and horizontally, lightly tighten bolts.
3. Close door, check for correct latching with door lock and for centring on striker.
4. Add or remove packing shims as necessary. Fully tighten bolts.
5. Carry out further adjustment as necessary. If full adjustment cannot be achieved carry out following:
6. Remove striker and nut plate.
7. Elongate striker bolt holes in 'B' post to increase movement in direction required.
8. Refit striker and adjust as necessary.

TAIL DOOR STRIKER - ADJUST

Service repair no - 76.37.25

Adjust

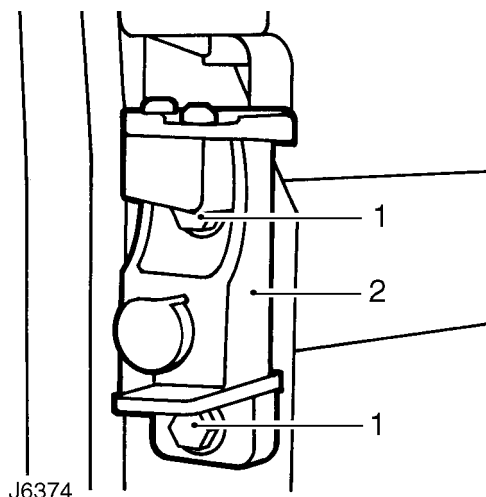

1. Loosen striker securing screws.
2. Adjust striker vertically and horizontally, lightly tighten screws.
3. Close door and check for correct latching with door lock.
4. Carry out further adjustment as necessary. If full adjustment cannot be achieved carry out following:
5. Remove striker and nut plate.
6. Elongate holes in body panel in direction required.
7. Refit striker and adjust as necessary.

FRONT DOOR - HARD TOP

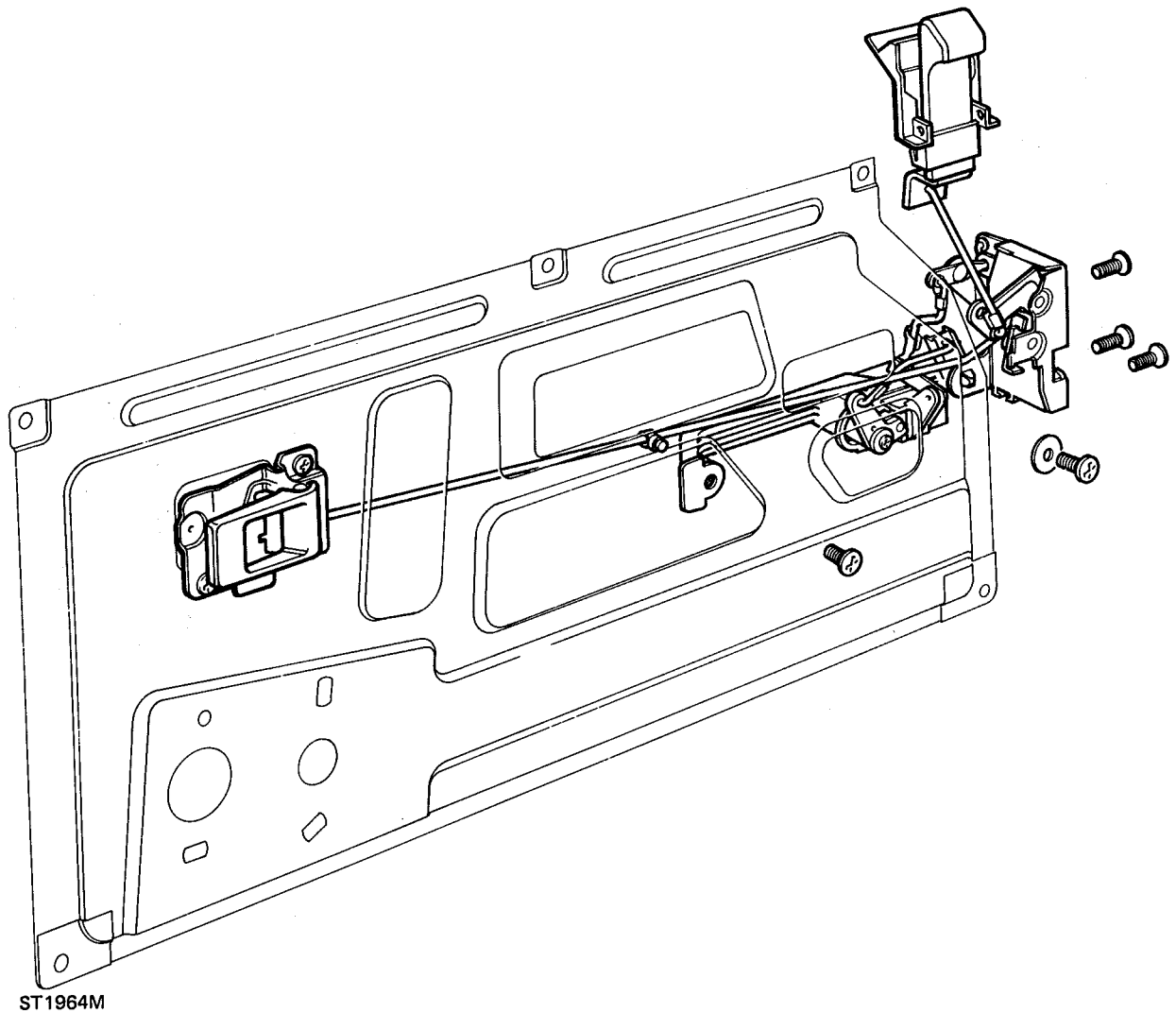

Front door lock mechanism - RH shown

TRIM CASING - FRONT DOOR

Service repair no - 76.34.01

Remove

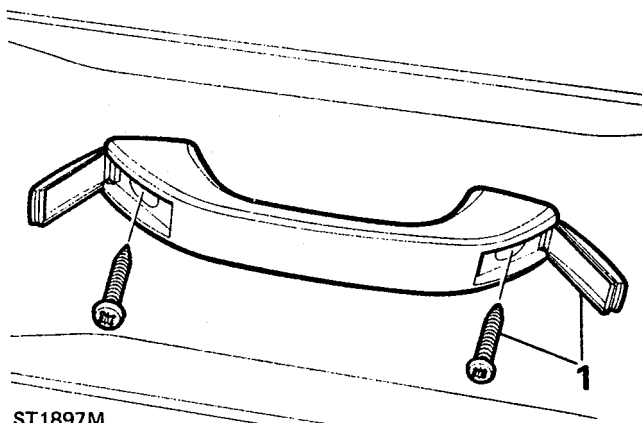

ST1897M

1. Prise open finisher caps, remove 2 screws, and detach door pull.

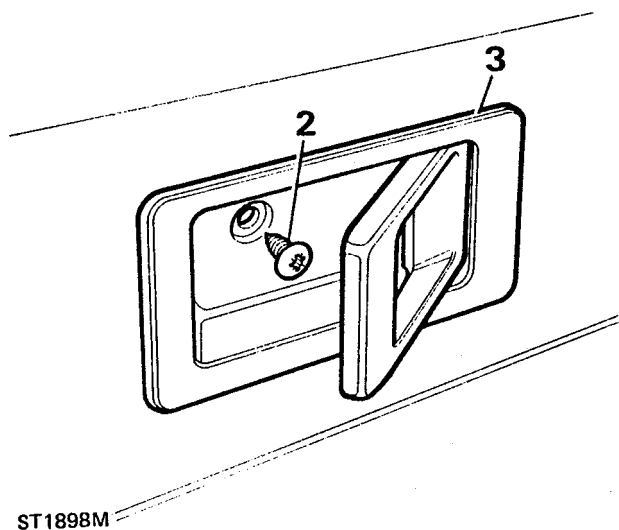

ST1898M

2. Remove single screw behind remote control lever.
3. Prise off remote control lever bezel.

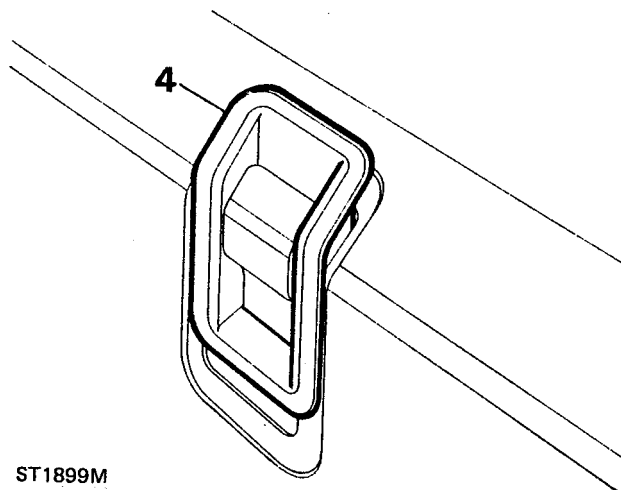

ST1899M

4. Prise off door locking button bezel.

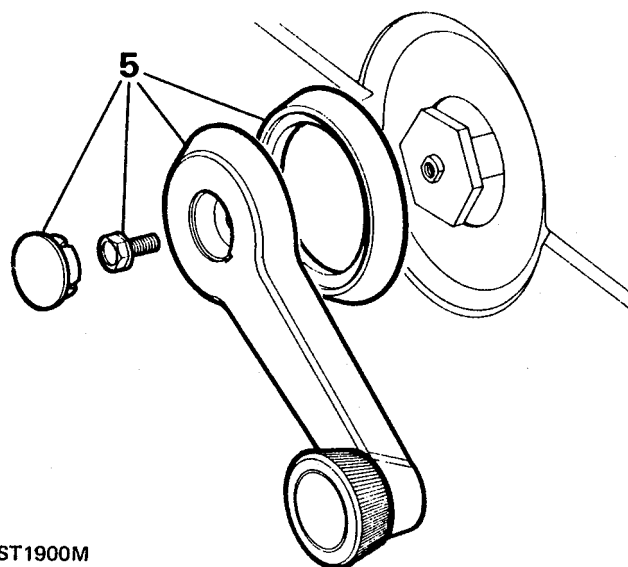

ST1900M

5. Prise out window regulator handle centre finisher, remove retaining screw, and withdraw handle and bezel.
6. Using a screwdriver to release trim fasteners, carefully ease trim casing from door.



Refit

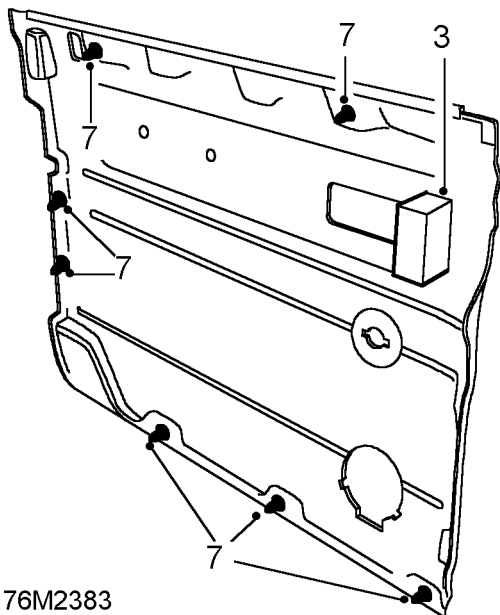

76M2383

7. Remove any trim fasteners held in door panel. Refit or insert new clips to trim casing.
8. Ensure that anti-vibration pads are in position and offer-up trim casing to door. Line-up fasteners with holes in door and firmly push trim into position.
9. Fit bezels to locking button and remote control lever.
10. Fit single screw behind remote control lever.
11. Fit door pull and secure with 2 screws and finisher caps.
12. Fit window regulator handle and retain with single screw and finisher.

MOUNTING PANEL - FRONT DOOR

Service repair no - 76.11.28

Remove

1. Remove door trim casing *See Trim casing - front door* and plastic sheet.

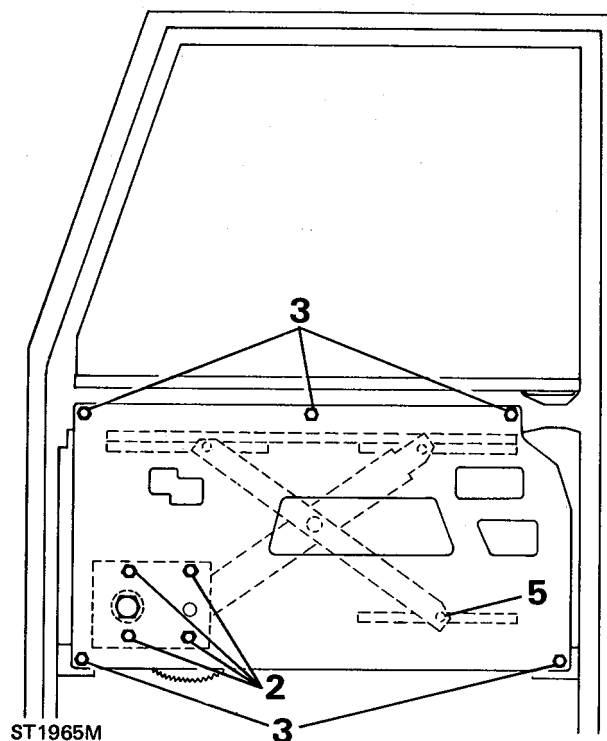

ST1965M

2. Remove 4 screws securing window regulator to mounting panel.
3. Remove 5 screws securing mounting panel to door frame.

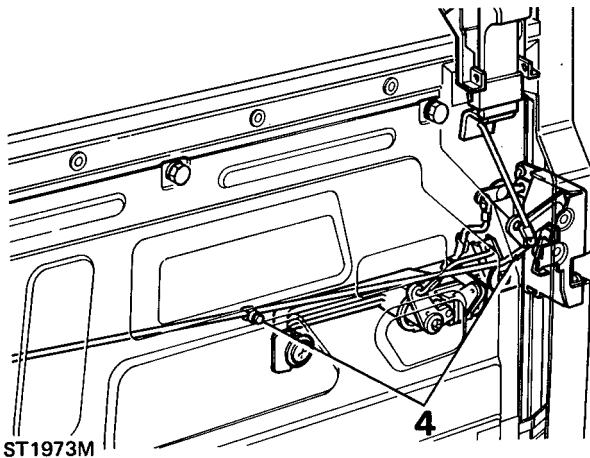

4. Release remote control lever rod from latch mechanism and from plastic clip in mounting panel.
5. Slide window regulator arm from mounting panel channel and remove panel with remote control lever and rod.

Refit

6. Engage window regulator arm in mounting panel channel.
7. Connect remote control rod to latch mechanism and secure with clip.
8. Fit mounting panel and retain with 5 screws.
9. Secure window regulator to mounting panel with 4 screws.
10. Raise and lower window to check for free movement.
11. Fit plastic sheet and door trim casing. *See Trim casing - front door*

SILL LOCKING BUTTON - FRONT DOOR

Service repair no - 76.37.29

Remove

1. Remove door trim casing. *See Trim casing - front door*
2. Peel back plastic sheet to expose mechanism.

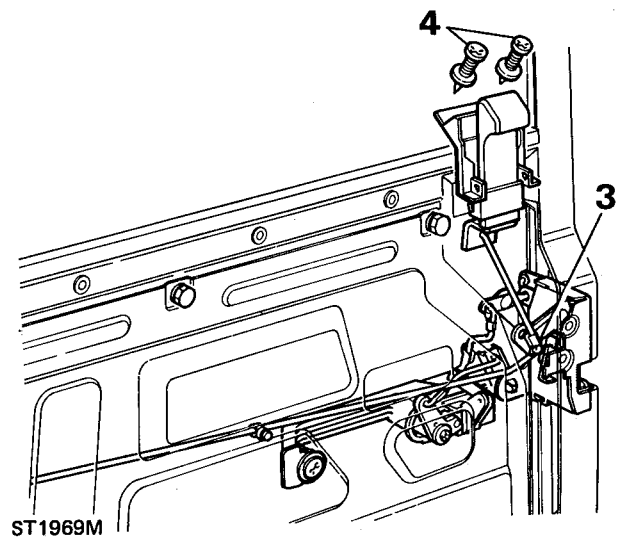

3. Release spring clip and disconnect operating rod from latch mechanism.
4. Remove 2 screws and withdraw locking button assembly.

Refit

5. Secure locking button assembly to door with 2 screws.
6. Connect operating rod to latch mechanism and secure with spring clip.
7. Re-seal plastic sheet and fit door trim casing. *See Trim casing - front door*



WINDOW REGULATOR - FRONT DOOR

Service repair no - 76.31.45

Remove

1. Remove door trim casing. *See Trim casing - front door*
2. Remove plastic sheet.
3. Temporarily fit handle, position window half open and support with a length of timber.

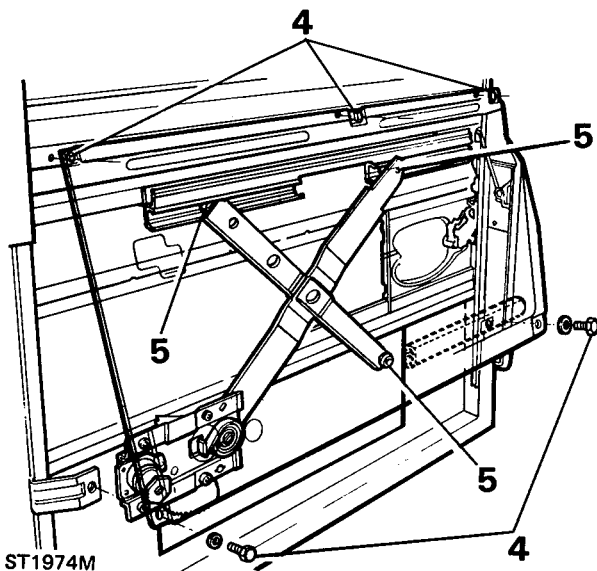

4. Remove 2 lower screws securing mounting panel to door and slacken 3 upper screws.
5. Remove 4 screws retaining window regulator to mounting panel and slide operating arms from channels attached to glass and mounting panel and remove regulator.

Refit

6. Insert regulator operating arms into channels.
7. Fit and tighten mounting panel lower screws and tighten upper screws.
8. Align holes in regulator with holes in mounting panel and secure with 4 screws.
9. Temporarily fit regulator handle and check that glass can be raised and lowered without tight spots.
10. Secure plastic sheet.
11. Fit door trim casing. *See Trim casing - front door*

REMOTE CONTROL LEVER - FRONT DOOR

Service repair no - 76.37.31

Remove

1. Remove door trim. *See Trim casing - front door*
2. Peel back sufficient of plastic sheet to gain access to remote lever.

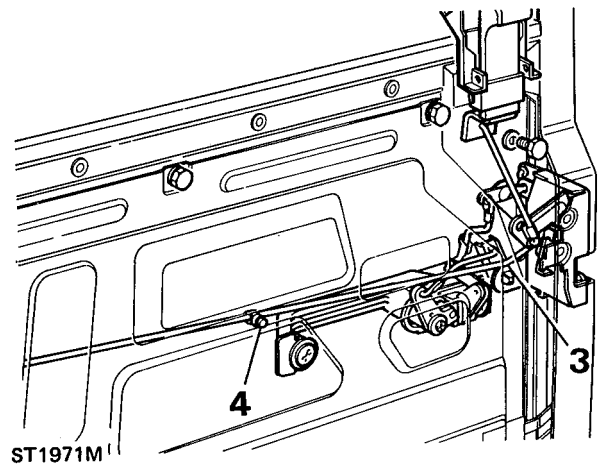

3. Release spring clip and disconnect control rod from latch mechanism.
4. Release control rod from plastic clip in mounting panel.

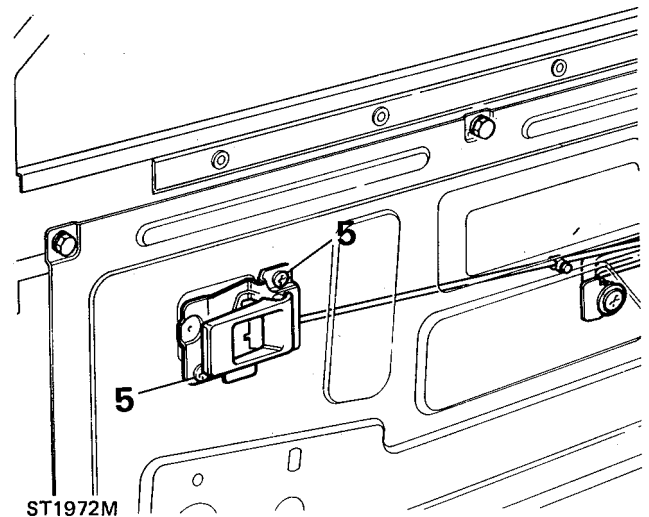

5. Remove 2 screws securing remote control lever to mounting panel and withdraw lever and control rod.

Refit

6. Feed control rod into position and loosely secure lever to mounting panel with 2 screws.
7. Connect control rod to latch mechanism and secure with spring clip.
8. Tighten control lever retaining screws.
9. Secure control rod to plastic clip in mounting panel.
10. Secure plastic sheet with adhesive.
11. Fit door trim casing. *See Trim casing - front door*

EXTERIOR HANDLE - FRONT DOOR

Service repair no - 76.58.01

Remove

1. Remove door trim casing. *See Trim casing - front door*

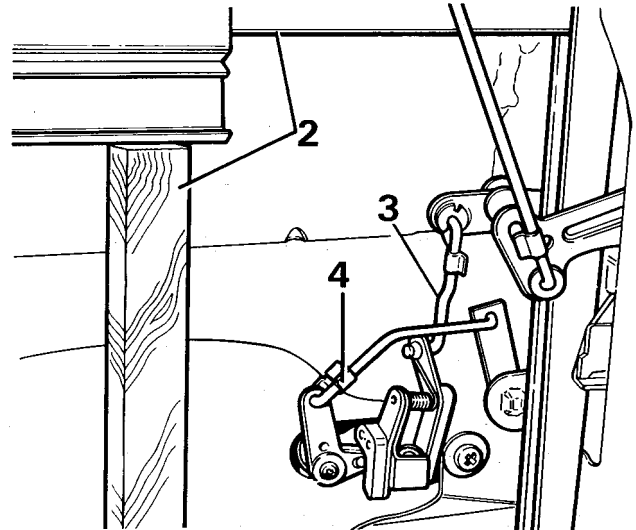

ST1982M

2. Remove mounting panel. *See Mounting panel - front door* and support glass with timber.
3. Disconnect operating rod from handle mechanism.
4. Disconnect rod from locking barrel lever.

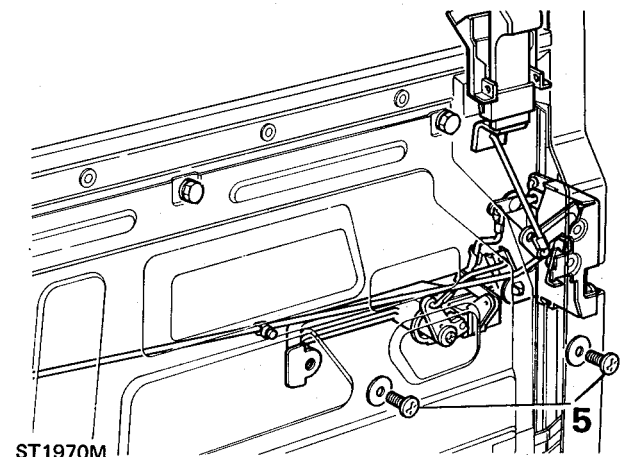

ST1970M

5. Remove 2 screws and withdraw handle assembly.

**Refit**

6. Fit handle to door ensuring that two bezels are in position - flat faces towards door, and secure with 2 screws.
7. Connect rod to handle operating lever and secure with spring clip.
8. Connect rod to locking barrel lever and retain with spring clip.
9. Fit mounting panel **See *Mounting panel - front door***
10. Fit door trim casing. **See *Trim casing - front door***

LATCH ASSEMBLY - FRONT DOOR

Service repair no - 76.37.12

Remove

1. Remove mounting panel. *See Mounting panel - front door* and support glass with timber.
2. Disconnect control rod from handle operating lever.

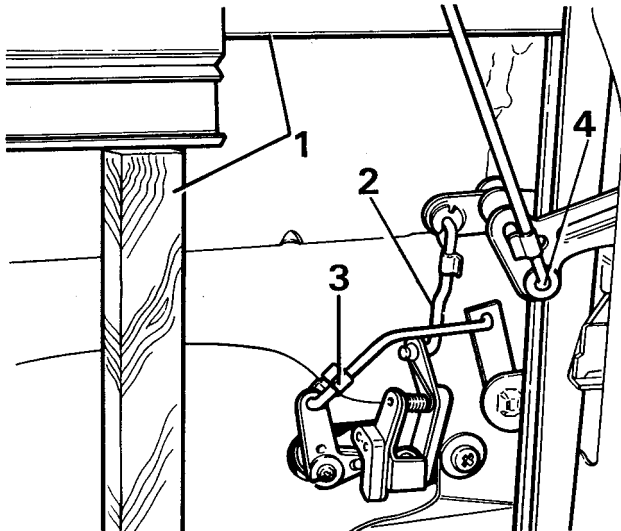

ST1983M

3. Disconnect control rod from locking lever on handle.
4. Disconnect locking button control rod from latch mechanism.
5. Remove 2 screws and remove handle assembly from door.
6. Remove 2 self-tapping screws retaining lower end of window glass runner.
7. Remove 3 screws securing latch assembly to door.
8. Whilst taking care not to damage runner, ease runner away from latch and manoeuvre latch assembly from door.

Refit

9. Carefully ease window runner away, sufficiently to enable latch to be located into position.
10. Secure latch to door with 3 screws.
11. Secure window runner with 2 screws ensuring that packing strip is in position and that screw heads are below bottom of runner to prevent damage to glass.

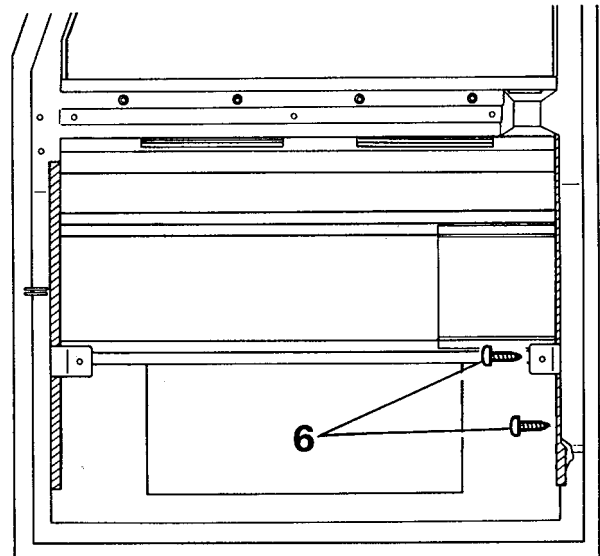

ST1977M

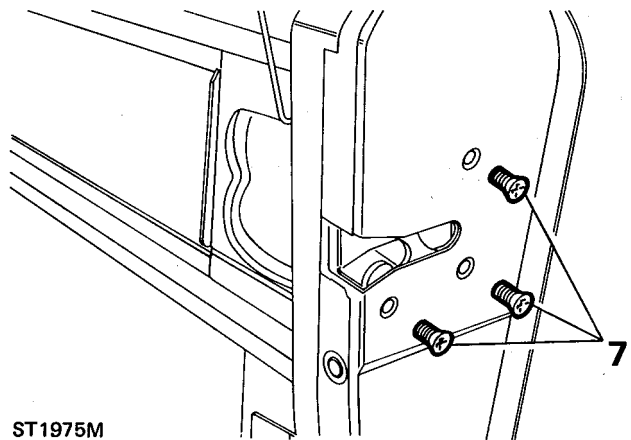

ST1975M

12. Fit handle with 2 screws, ensuring that bezels are in position.
13. Connect control rod to handle operating lever and secure with spring clip.
14. Connect control rod to locking lever and retain with spring clip.
15. Connect locking button control rod to latch lever and secure with spring clip.
16. Fit mounting panel. *See Mounting panel - front door*



DOOR GLASS - FRONT DOOR

Service repair no - 76.31.01

Remove

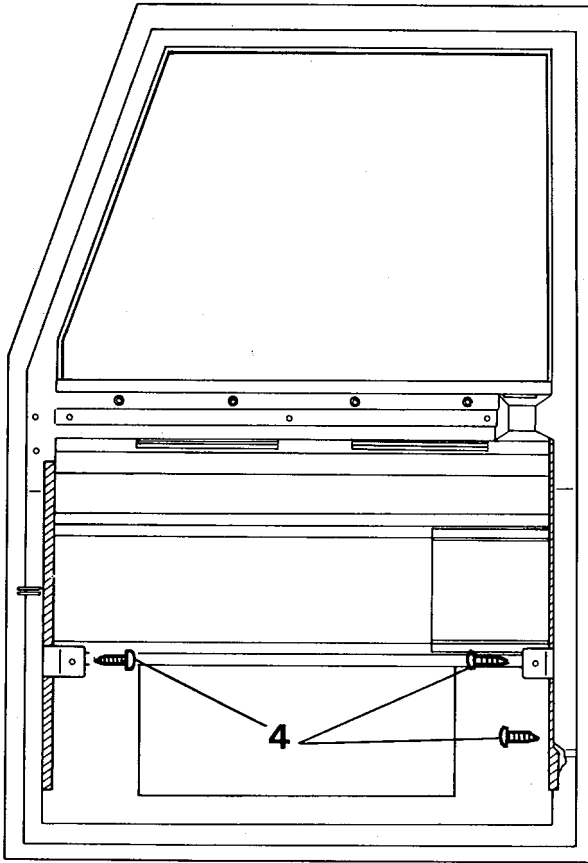

ST1976M

1. Remove mounting panel. *See Mounting panel - front door*
2. Remove window regulator. *See Window regulator - front door*
3. Push glass up to top of its travel and support with a suitable length of timber.
4. Remove 2 self tapping screws securing window glass runner on latch side of door and single screw from hinge side.

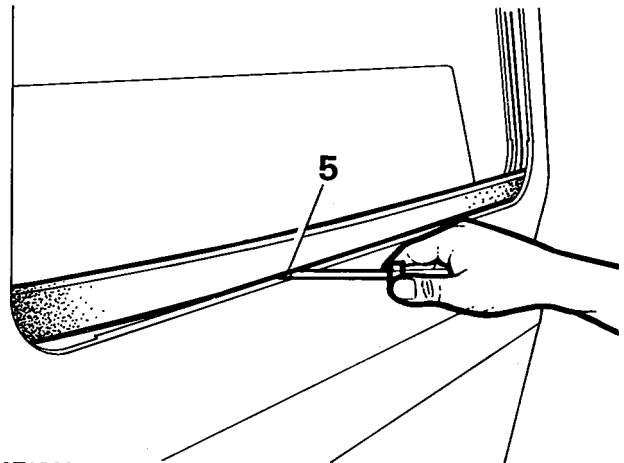

ST1966M

5. Taking care not to damage paint, prise exterior waist weather strip from door.
6. Remove timber support and lower glass to bottom of door.

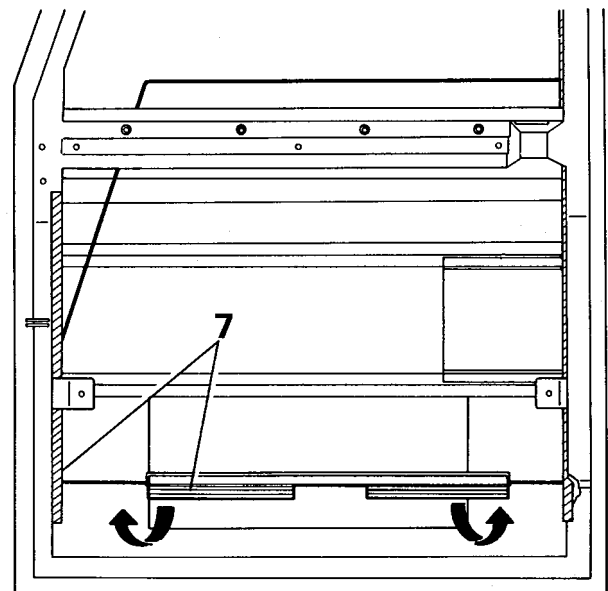

ST1968M

7. Ease runner from glass at hinge side of door, lift glass over bottom edge of door and withdraw.

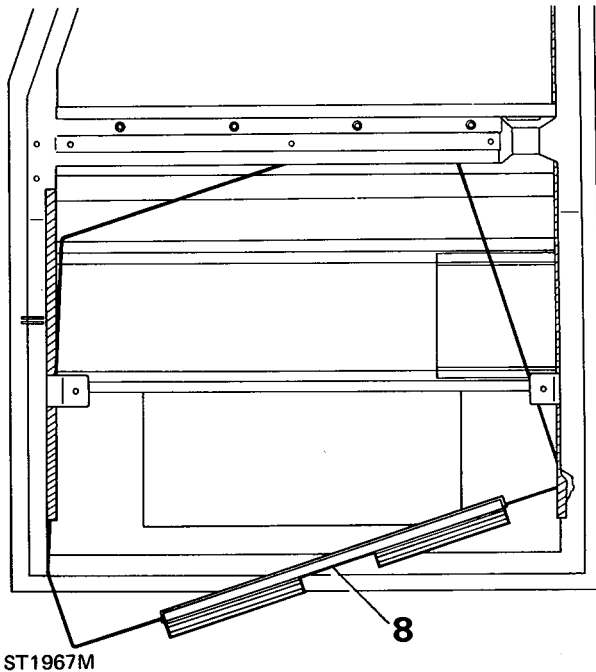

Refit

8. Insert glass into runners at an angle as illustrated.
9. Whilst lifting glass, position it squarely in runners, raise to top of travel and insert timber support.
10. Secure hinge side runner with single screw ensuring that packing strip is in position.
11. Locate packing strip and secure opposite runner with 2 screws. Ensure that all 3 screw heads are well below bottom of runners to prevent damage to glass.
12. Locate regulator in window lift channels.
13. Fit mounting panel **See Mounting panel - front door**

LOCKING BARREL - FRONT DOOR

Service repair no - 76.37.39

Remove

1. Remove door trim **See Trim casing - front door** and plastic sheet.
2. Remove mounting panel **See Mounting panel - front door**

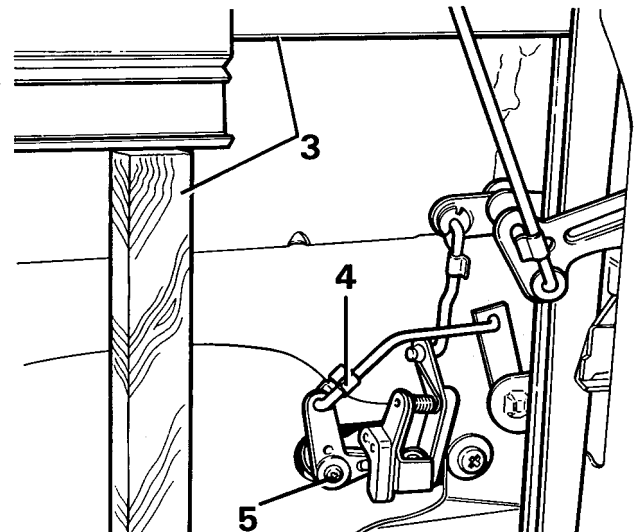

3. Raise and support glass to gain access to latch mechanism.
4. Release spring clip and disconnect rod from lock operating lever.
5. Remove single screw and withdraw lock lever assembly.

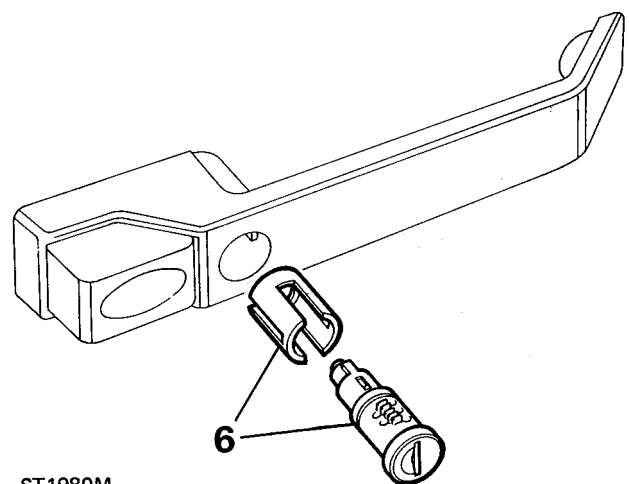

6. Withdraw lock barrel from exterior door handle complete with locking sleeve.

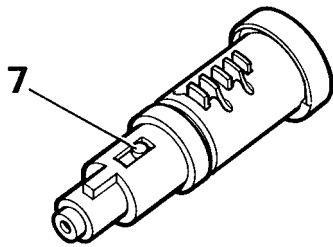

ST1979M

7. To remove barrel from plastic retaining sleeve, depress spring loaded button and withdraw sleeve.

Refit



NOTE: If a new barrel is being fitted, check that number on barrel coincides with number on accompanying key.

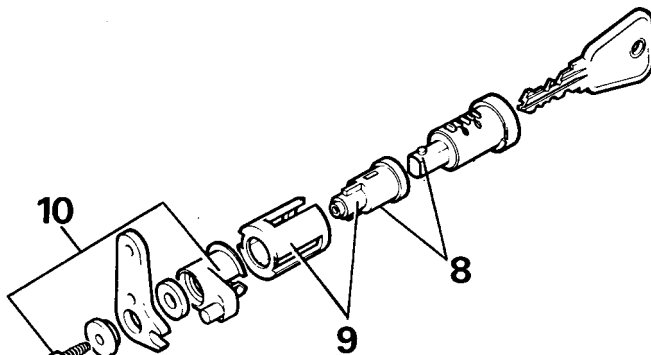

ST1978M

8. Push plastic retaining sleeve over barrel until spring loaded peg locks it into position.
9. Fit barrel and plastic sleeve assembly to locking sleeve and insert into exterior handle reversing instruction 6.
10. Assemble lock lever components as illustrated and from inside of door panel, fit them to barrel assembly with single screw.
11. Connect operating rod to lock lever and secure with spring clip, reversing instruction 4.
12. Fit mounting panel. **See Mounting panel - front door**

REAR SEAT CUSHION

Service repair no - 78.10.18/99

Remove

1. Release seat cushion stowage strap.
2. Remove 4 bolts and spring washers and lift seat cushion from pivot brackets.
3. Remove 4 bolts, plain washers, spring washers and nuts. Detach both pivot brackets from wheel arch.

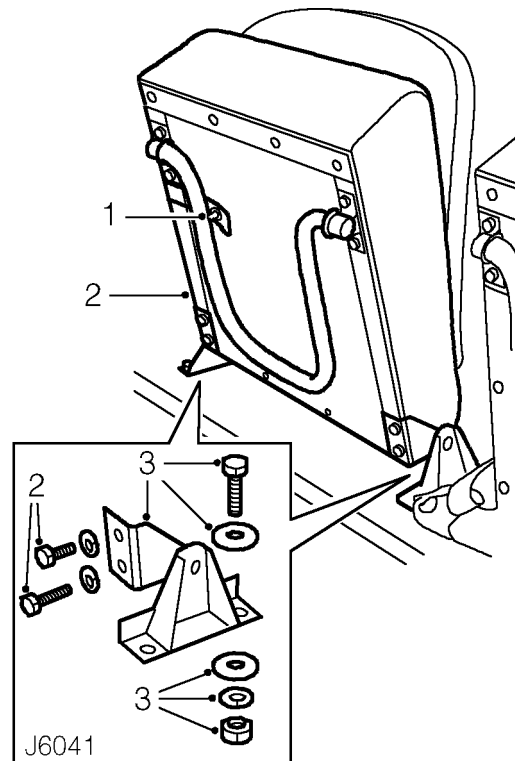

Refit

4. Secure pivot brackets to wheel arch and tighten bolts to **10 Nm, 7 lbf ft.**
5. Position seat cushion in pivot brackets and secure with 4 bolts and spring washers.
6. Fit stowage strap.

REAR SEAT SQUAB

Service repair no - 78.10.58/99**Remove**

1. Release seat cushion stowage strap and lower seat cushion.
2. Loosen 2 bolts securing seat squab brackets to body side.
3. Remove 2 bolts, plain washers, spring washers and nuts securing seat squab to wheel arch.
4. Lift and release brackets from retaining bolts and remove seat squab.

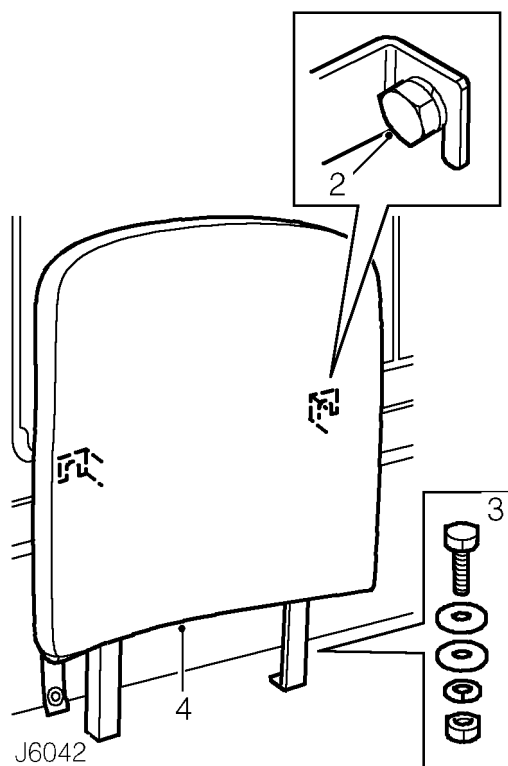
**Refit**

5. Lower seat squab brackets over retaining bolts, tighten bolts to **10 Nm, 7 lbf ft.**
6. Secure seat squab to wheel arch, tighten bolts to **10 Nm, 7 lbf ft.**
7. Raise seat cushion and fit stowage strap.



REAR SEAT BELTS

Service repair no - 76.73.18

Remove

1. Release belt straps from buckles on both seats.
2. Raise both seat cushions and secure with stowage straps.
3. Unscrew bolt and remove bracket and inner seat belt straps.

4. Unscrew bolt and remove rear seat buckle strap from wheel arch.
5. Unscrew bolt and remove front seat buckle strap from interior roll-over bar mounting.

Refit

6. Reverse removal procedure, ensuring seat belt fixing bolts are tightened to **32 Nm, 24 lbf ft**.

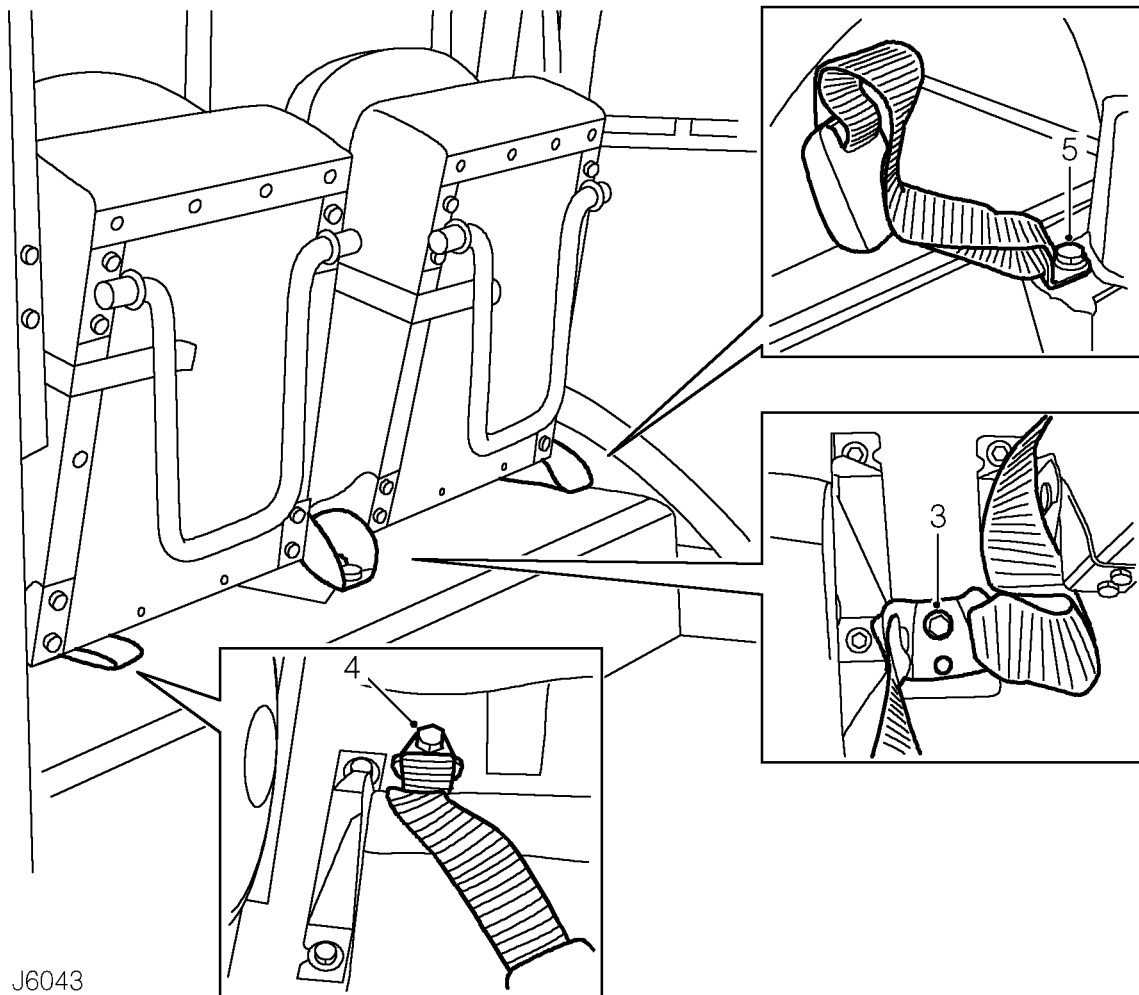

J6043

FRONT SEAT BELTS

Service repair no - 76.73.13

Remove

1. Remove cap and unscrew seat belt guide bracket fixing bolt from 'B/C' post.
2. Remove 3 bolts and plain washers securing seat belt mounting bracket to body on outside of seat base.

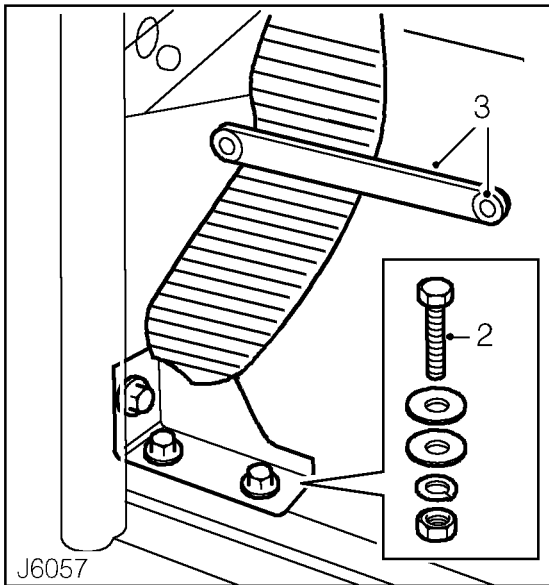
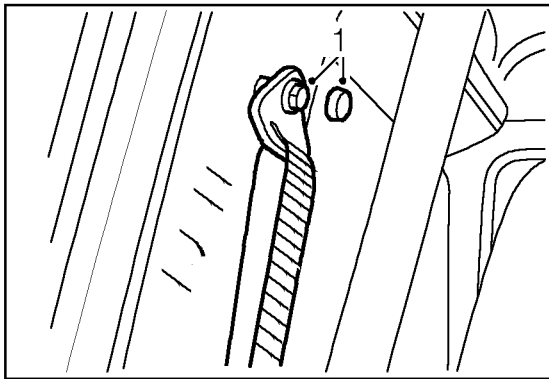

3. Prise seat belt retaining clip from side of seat mounting and remove trim studs.
4. Unscrew bolt and remove seat belt inertia reel from roll-over bar mounting bracket.
5. Remove seat belt and inertia reel assembly.
6. Unscrew bolt and washer and remove seat belt buckle stalk from roll-over mounting bracket.
7. On the driver's side, disconnect harness plug connector of audible warning circuit at buckle stalk.

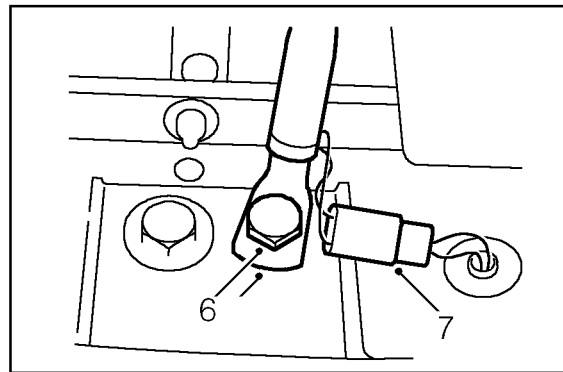
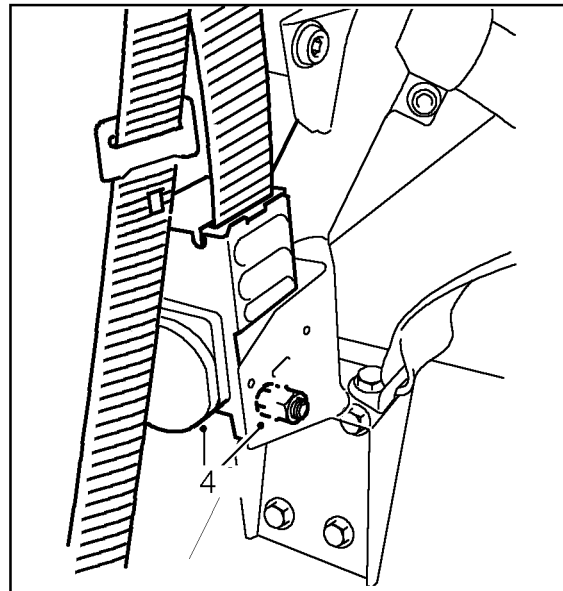

Refit

8. Reconnect harness plug of audible warning circuit.
9. Position stalk on roll-over bar mounting bracket and tighten fixing bolt to **32 Nm, 24 lbf ft.**
10. Secure seat belt inertia reel to roll-over bar mounting and tighten bolt to **32 Nm, 24 lbf ft.**
11. Secure seat belt bucket to floor on outside of seat base and tighten bolts to **23 Nm, 17 lbf ft).**
12. Fit seat belt retaining clip to side of seat base and secure with trim studs.
13. Extend belt from inertia reel, secure slide bracket to 'B/C' post and tighten bolt to **32 Nm, 24 lbf ft.**
14. Refit fixing bolt cap.



SIDE TRIM PANEL - HARD TOP

Service repair no - 76.13.70

Remove

1. Remove rear seat squabs. *See Rear seat squab*
2. Remove rear end trim panel. *See Rear end trim panel - hard top*
3. Prise cap from front seat belt upper guide retaining bolt.

4. Unscrew retaining bolt and remove seat belt from 'B/C' post.
5. Carefully prise 2 trim studs from 'B/C' post.
6. Remove 4 bolts securing side trim panel and forward seat support to body side.
7. Release top edge of side trim panel by striking upwards with the hand to disengage 3 spring clips.
8. Carefully pull trim panel rearwards to clear interior roll-over bar.
9. Remove side trim panel from vehicle.

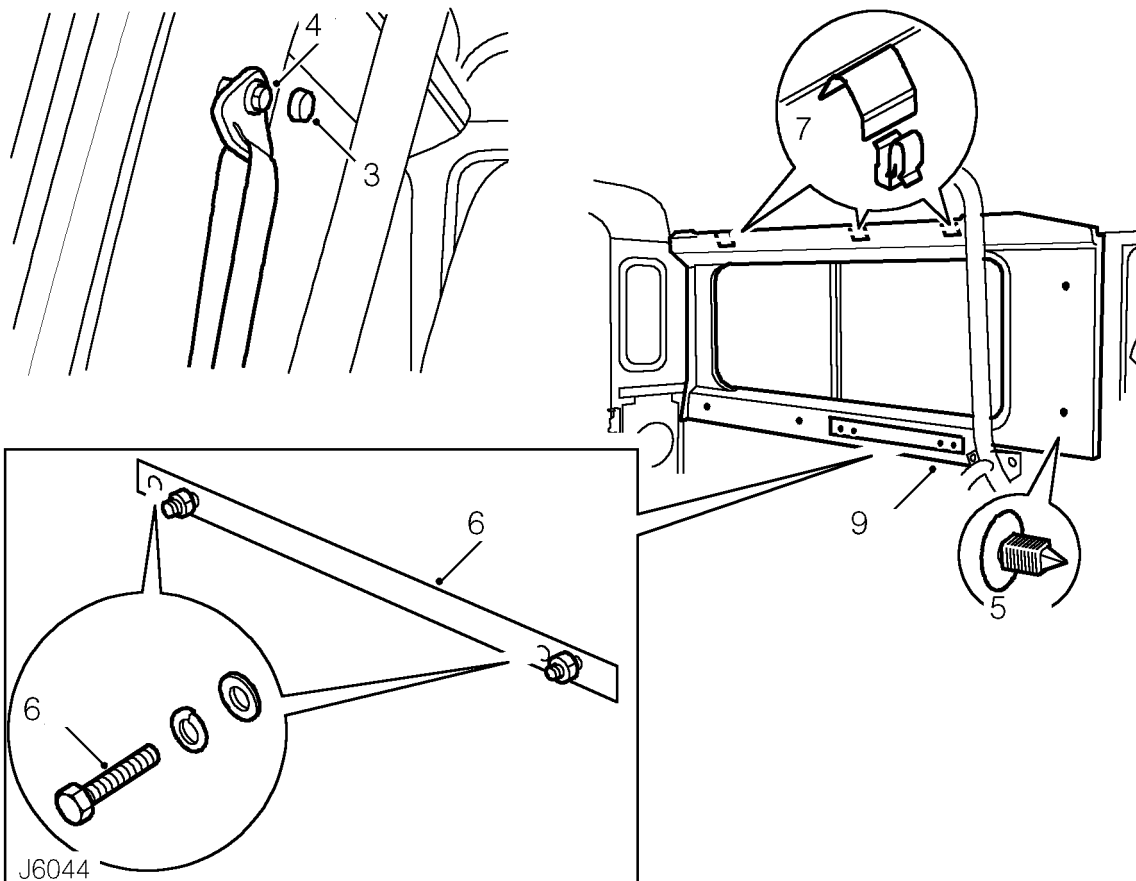

Refit

10. Fit new spring clips to the 3 brackets on top edge of side trim panel.
11. Carefully pull trim panel behind interior roll-over bar.
12. Align trim panel, ensuring it is correctly positioned around side window.
13. Locate trim panel spring clips on inner cant rail and press firmly down to secure top edge of trim panel.
14. Align bosses of trim panel and forward seat support bracket with body side fixing holes and secure with bolts and washers. **Do not** fully tighten at this stage.
15. Fit trim stud to secure bottom edge of trim panel to 'B/C' post.
16. Secure seat belt guide to 'B/C' post, tighten bolt to **32 Nm, 24 lbf/ft** and fit cap.
17. Fit rear end trim panel. *See Rear end trim panel - hard top*
18. Fit rear seat squab. *See Rear seat squab*

REAR END TRIM PANEL - HARD TOP

Service repair no - 76.13.71

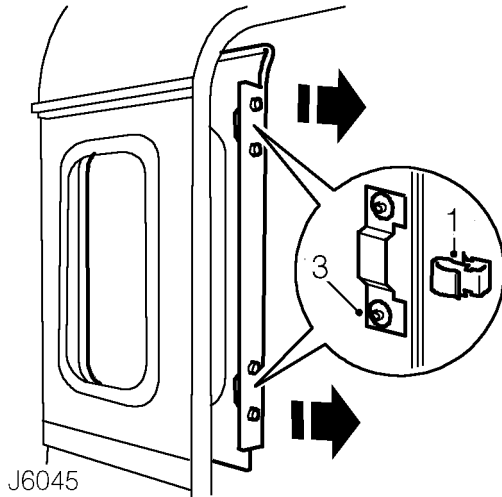
Remove

1. Pull edge of rear end trim panel firmly to release the two spring retaining clips from vertical rail at door aperture.
2. Remove rear end trim panel.

Refit

3. Fit new spring clips to the two brackets on side of trim panel.
4. Position outboard edge of trim panel in corner to abut side trim panel and locate spring clips on vertical rail.
5. Press edge of trim panel firmly to secure in position.

REAR GRAB HANDLE - HARD TOP

Service repair no - 76.58.35

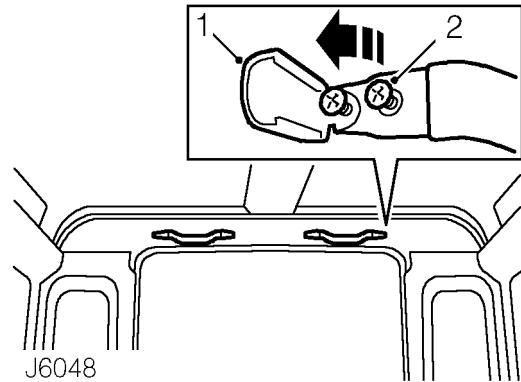
Remove

1. Carefully prise top and bottom edges of finisher caps from grab handle and then hinge outwards to gain access to fixing screws.
2. Remove 4 fixing screws and detach grab handle from rear end trim panel.

Refit

3. Position grab handle on rear end trim panel and secure with 4 fixing screws.
4. Press finisher caps over screws.



REAR END LINING - HARD TOP

Service repair no - 76.64.12

Remove

1. Remove rear end trim panel. *See Rear end trim panel - hard top*
2. Remove rear grab handles. *See Rear grab handle - hard top*

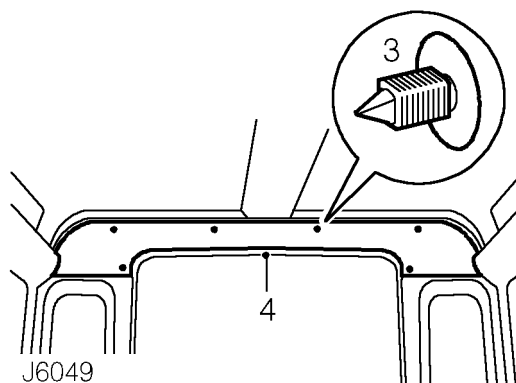

3. Carefully prise out 6 trim studs securing rear end lining to mounting brackets.
4. Remove rear end lining.

Refit

5. Position rear end lining on mounting brackets and secure with 6 trim studs.
6. Fit rear grab handles. *See rear grab handle - hard top*
7. Fit rear end trim panel. *See rear end trim - hard top*

TRIM CASING - TAIL DOOR

Service repair no - 76.34.09

Remove

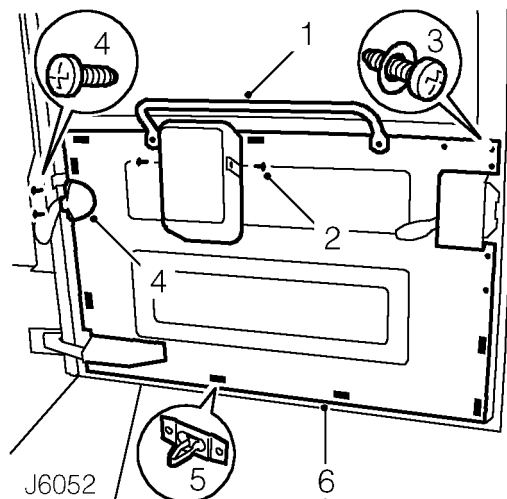

1. Unscrew 2 bolts and remove grab handle from rear door.
2. Remove 2 screws and detach wiper motor cover.
3. Remove 7 screws securing trim casing to door.
4. Remove 2 screws and lift wiper motor harness cover from harness support bracket.
5. Carefully release 8 clips securing trim casing to door.
6. Remove trim casing and collect door lock cover.

Refit

7. Position door lock cover, fit trim casing and secure with clips.
8. Fit harness cover and secure with two screws.
9. Secure door panel with retaining screws.
10. Position wiper motor cover and secure with 2 screws.
11. Position grab handle and secure with 2 bolts.

DOOR LOCK - TAIL DOOR

Service repair no - 76.37.16

Remove

1. Remove door trim casing. *See trim casing - tail door*

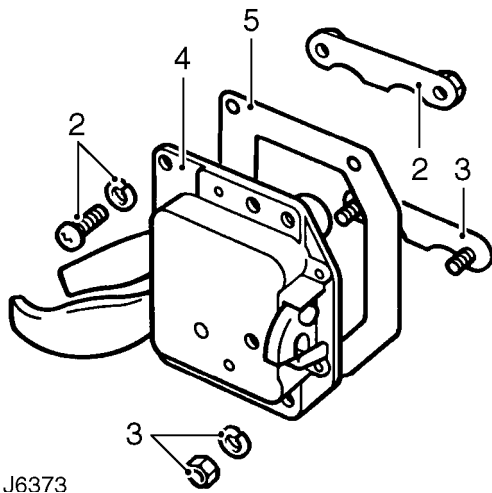

2. Remove screws, washers and nut retainer plate securing top of lock to door.
3. Remove nuts, washers and stud retainer plate securing bottom of lock to door.
4. Withdraw lock assembly.
5. Remove door lock gasket.
6. Clean sealant from retainer plates.
7. Insert key into barrel.
8. Depress lock barrel plunger and withdraw barrel from lock.

Refit

9. Fit new barrel into lock.
10. Apply sealant to lock retainer plates.
11. Fit lock to door with a new gasket.
12. Secure with retainer plates, screws, washers and nuts.
13. Close door and check for correct latching with striker. Adjust striker as necessary. *See Adjustment, Tail door striker - adjust*
14. Fit door trim casing. *See trim casing - tail door*



SUN ROOF

Service repair no - 76.83.01

Remove

1. Open sun roof fully.
2. Disengage spring lock from operating handle catch.
3. Holding sun roof at both sides, release hinges from locating brackets at front of outer frame.

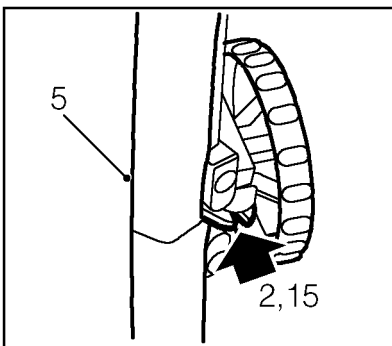
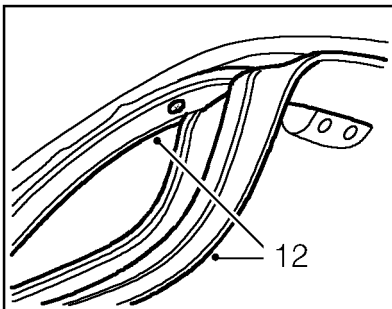

J6054

4. Remove sun roof.
5. Starting from centre rear, peel headlining finisher from inner frame.
6. Remove 18 screws securing inner frame to outer frame and detach inner frame.
7. Lift outer frame from roof.



NOTE: Assistance may be required to remove the sun roof assembly.

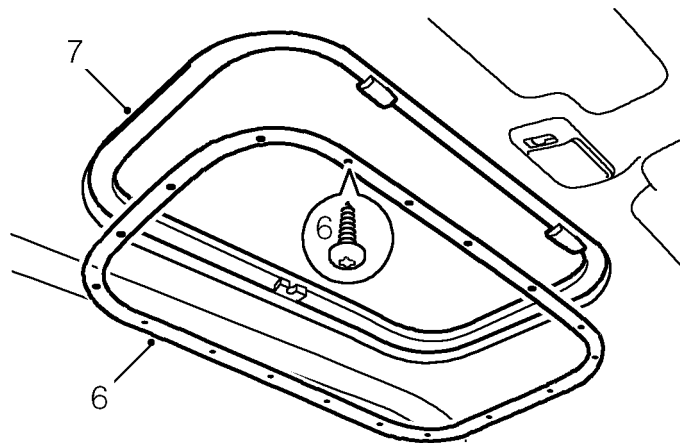
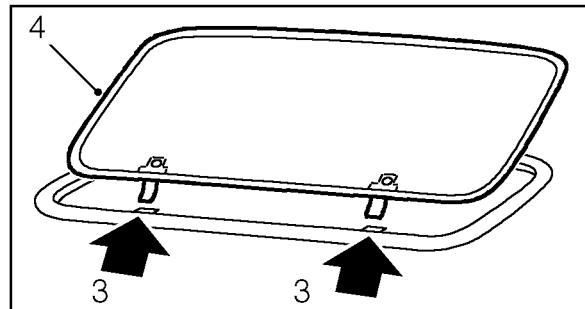

Refit

8. Clean roof area around outer frame seating.
9. Position outer frame on roof.
10. Fit inner frame to headlining and secure to outer frame with 18 screws but do not fully tighten.
11. Check alignment of inner and outer frames with roof mounting and headlining, adjust as necessary, and fully tighten fixing screws to **10 Nm, 7 lbf ft.**
12. Starting from centre rear, fit headlining finisher lip into locating channel of inner frame.
13. Press finisher firmly over inner frame and continue around complete frame, ensuring finisher lies flat on headlining.
14. Fit sun roof hinges fully into locating brackets on outer frame, and lower the glass panel.
15. Engage operating handle catch with spring lock of outer frame and close sunroof.

INTERIOR MIRROR

Service repair no - 76.10.51

Remove

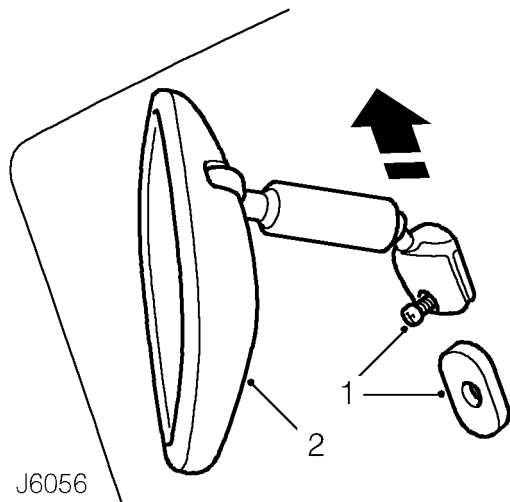

1. Remove retaining screw securing mirror adjustment arm to mounting slug.
2. Slide adjustment arm up from mounting slug and remove mirror.

Refit

3. Slide mirror adjustment arm over mounting slug.
4. Secure mirror with retaining screw.

SUN VISORS

Service repair no - 76.10.47

Remove

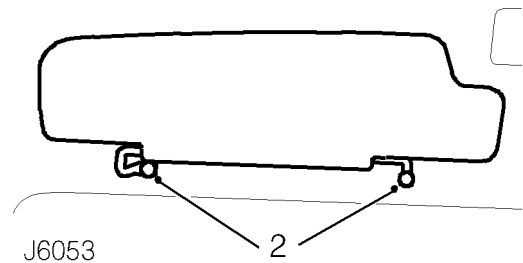

1. Raise sun visor.
2. Remove 2 screws and collect sun visor.

Refit

3. Position sun visor and secure with 2 screws.



FRONT HEADLINING - HARD TOP

Service repair no - 76.64.10

Remove

1. Remove sun roof headlining finisher.
2. Remove sun visors. **See Sun visors**
3. Remove interior lamp. **See ELECTRICAL, Repair, Interior lamp**
4. Remove 4 retaining screws and detach both 'A' post trims.
5. Remove caps and unscrew front seat belt fixing bolts from 'B/C' posts.
6. Carefully prise side trim panel cap fastener from 'B/C' posts.

7. Carefully prise 2 cap fasteners, from each side, securing headlining to body at door apertures.
8. Carefully prise out 7 cap fasteners securing front and rear headlinings to roof.
9. From both sides, pull side trim panel inwards enough to release rear corners of front headlining.
10. Lower headlining, disconnect interior lamp harness plug at 'A' post, and remove headlining from vehicle.



NOTE: Take care not to bend the headlining on removal and refitting.

11. **Do not carry out further dismantling if component is removed for access only.**
12. Remove interior lamp harness from headlining.

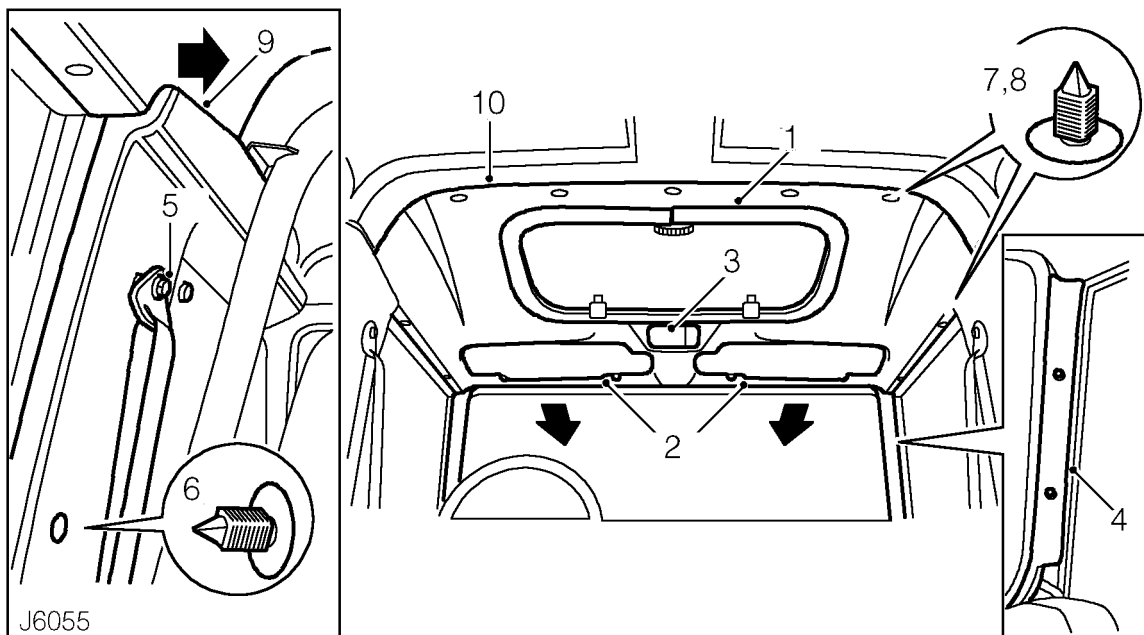

Refit

13. Tape interior lamp harness to headlining.
14. With assistance, raise headlining to roof.
15. Carefully pull side trim panel inwards, on both sides, and slide headlining behind trim panel.
16. Position front headlining into recess of rear headlining and secure both to roof mounting brackets with cap fasteners.
17. Secure both sides of front headlining to body at door apertures with cap fasteners.
18. Fit side cap fasteners at 'B/C' posts.
19. Secure seat belts to 'B/C' posts and tighten bolts to **32 Nm, 24 lbf ft**. Fit caps to bolts.
20. Fit 'A' post trims.
21. Fit interior lamp. **See ELECTRICAL, Repair, Interior lamp**
22. Fit sun visors. **See Sun visors**
23. Fit sun roof headlining finisher.

REAR HEADLINING - HARD TOP

Service repair no - 76.64.11

Remove

1. Remove rear end trim panel. *See Rear end trim panel - hard top*
2. Remove side trim panels. *See Side trim panel - hard top*
3. Remove rear grab handles. *See Rear grab handle - hard top*
4. Remove rear end lining. *See Rear end lining hard top*
5. Remove rear interior lamp. *See ELECTRICAL, Repair, Interior lamp*
6. Remove interior roll-over bar. *See Interior roll-over bar - hard top*
7. Carefully prise out 7 trim studs securing rear and front headlining to roof mounting brackets.
8. Release front corners of headlining from cant rail, on both sides.
9. Pull headlining forwards sufficiently to clear rear end lining mounting brackets.
10. Release rear corners of headlining from cant rail, on both sides.
11. Lower rear headlining from roof and remove from vehicle.



NOTE: Take care not to bend headlining on removal and refitting.

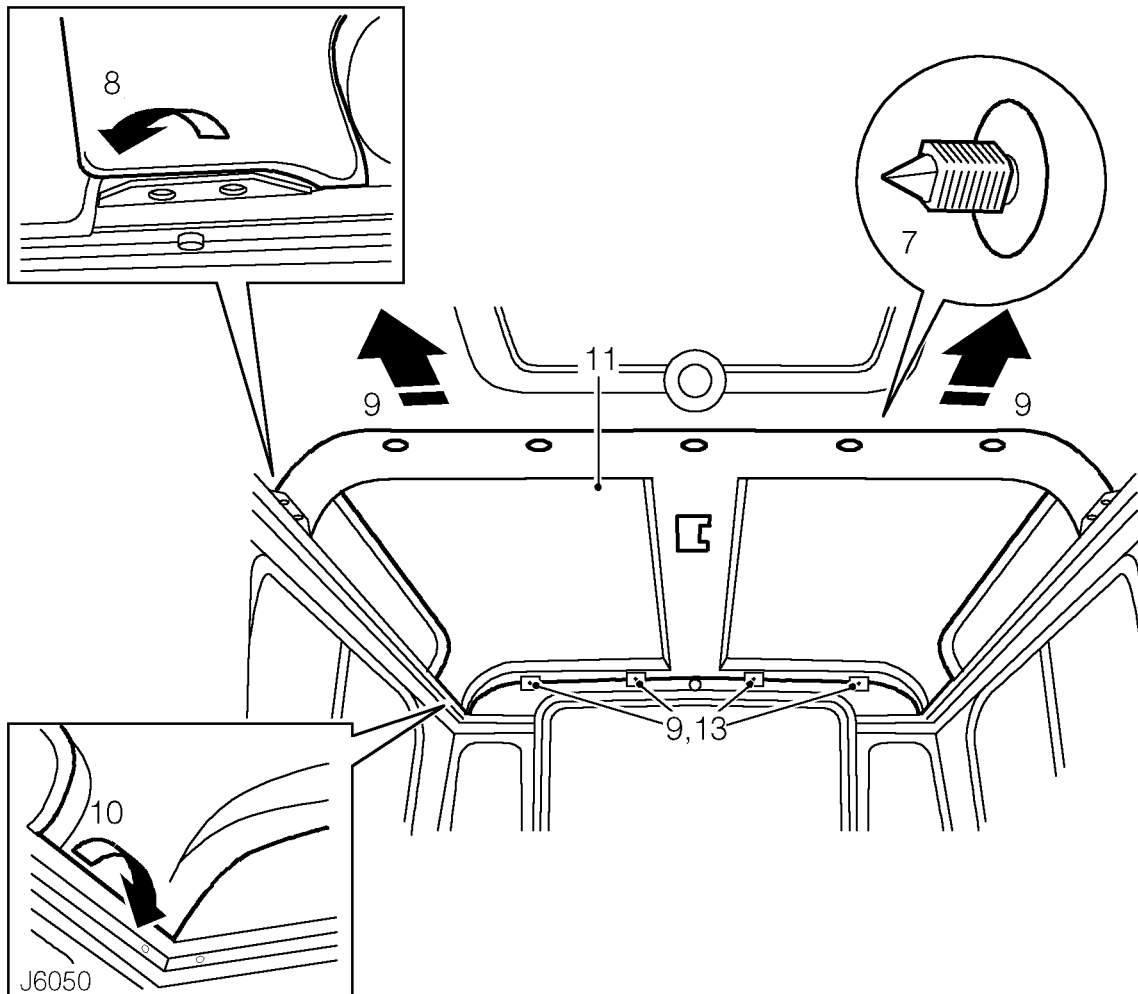



Refit

12. With assistance, position rear headlining to roof and locate rear corners in cant rail.
13. Push headlining rearwards and position over rear end lining mounting brackets.
14. Locate front corners of headlining in cant rail.
15. Position front edge of rear headlining over front headlining and secure with trim studs.
16. Adjust rear headlining to achieve good fit at all corners.
17. Fit rear interior lamp. *See ELECTRICAL, Repair, Interior lamp*
18. Fit interior roll-over bar. *See Interior roll-over bar - hard top*
19. Fit rear end lining. *See Rear end lining - hard top*
20. Fit rear grab handles. *See Rear grab handle - hard top*
21. Fit side trim panels. *See Side trim panel - hard top*
22. Fit rear end trim panels. *See Rear end trim panel - hard top*

BONNET LOCK

Service repair no - 76.16.21

Remove

1. Open bonnet.

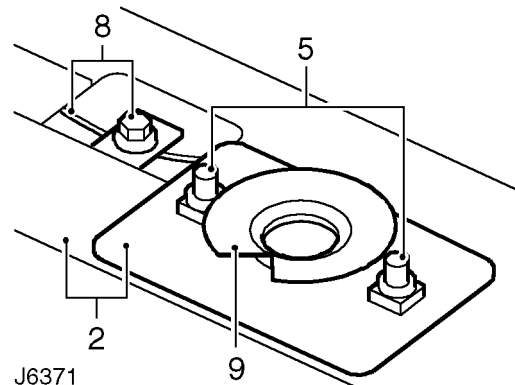

2. Mark position of guide plate and lock to bonnet platform.
3. Remove 8 screws securing grille.
4. Remove grille.
5. Remove 2 bolts securing guide plate and lock.
6. Remove guide plate.
7. Release spring securing lock to bonnet platform.
8. Slacken clamping bolt securing bonnet release cable.
9. Remove lock.

Refit

10. Fit spring between lock and bonnet platform.
11. Position lock and guide plate to bonnet platform and nip up bolts.
12. Position guide plate and lock to position marks and tighten bolts to **10 Nm. 7 lbf/ft.**
13. Fit cable to lock and tighten clamping bolt.
14. Check operation of release cable and adjust if necessary.
15. Fit grille and tighten securing screws.
16. Close bonnet.

BONNET RELEASE CABLE

Service repair no - 76.16.29

Remove

1. Open bonnet.
2. Remove 8 screws securing grille.
3. Remove grille.

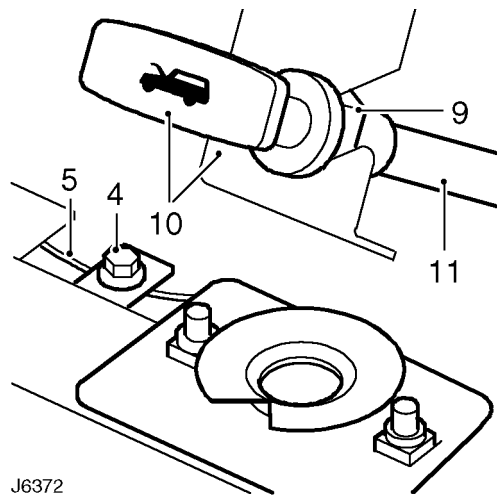

4. Slacken clamping bolt securing bonnet release cable.
5. Remove cable from lock.
6. Release cable from clip on underside of bonnet platform.
7. Feed cable through valance.
8. Collect cable grommet.
9. Loosen clamping nut securing bonnet release pull to mounting bracket.
10. Remove bonnet release pull from mounting bracket.
11. Withdraw cable through bulkhead.

Refit

12. Feed cable through bulkhead and fit bonnet release pull to mounting bracket. Tighten clamping nut.
13. Route cable along inner wing.
14. Feed cable through valance.
15. Fit grommet between cable and valance.
16. Fit cable to securing clip on underside of bonnet platform.
17. Fit cable to lock and tighten clamping bolt.
18. Check operation of release cable and bonnet lock and adjust if necessary.
19. Fit grille and tighten screws.
20. Close bonnet.



LOWER FASCIA PANEL (HEATER DUCT) ASSEMBLY

Service repair no - 76.46.05

Remove

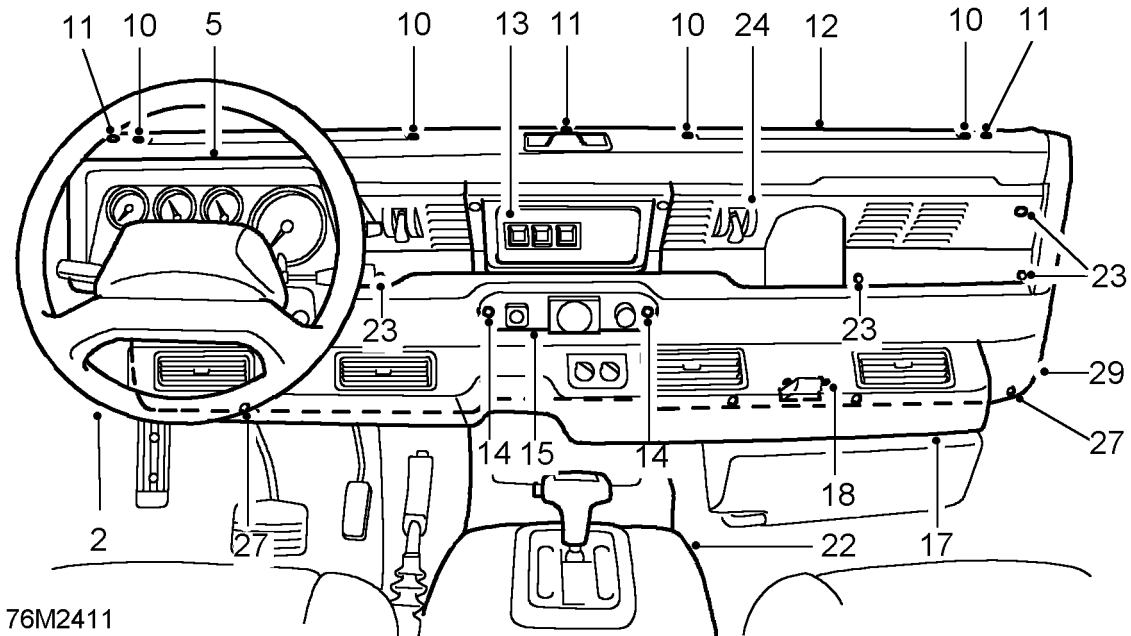

1. Disconnect battery.
2. Remove steering wheel. If necessary, use puller LRT-57-014.
6. Disconnect heater control cable. **See HEATING AND VENTILATION, Repair, Heater control cable - air distribution**

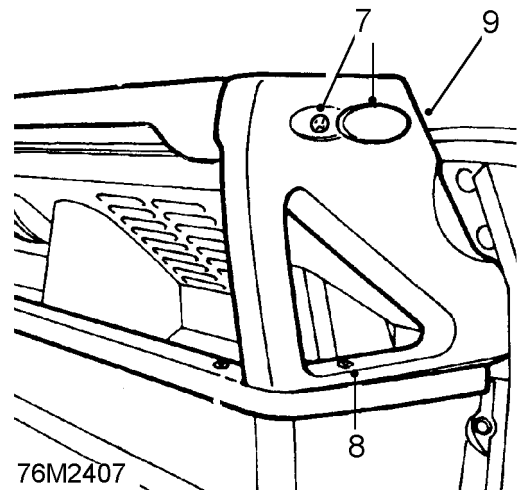
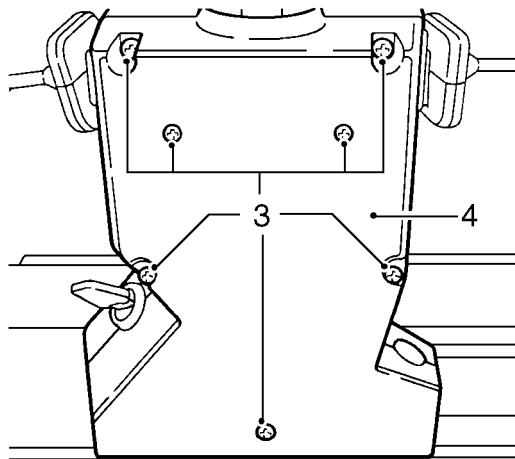

3. Remove 7 screws and lift top half of nacelle from steering column switch assembly.
4. Ease bottom half of nacelle from switch gaiters/grommets and remove.
5. Remove instrument panel. **See INSTRUMENTS, Repair, Instrument panel**
7. Prise out Land Rover decal and remove screw securing grab handle to crash pad.
8. Remove screw securing grab handle to lower fascia panel.
9. Lift grab handle to release locating pins from fascia panel.

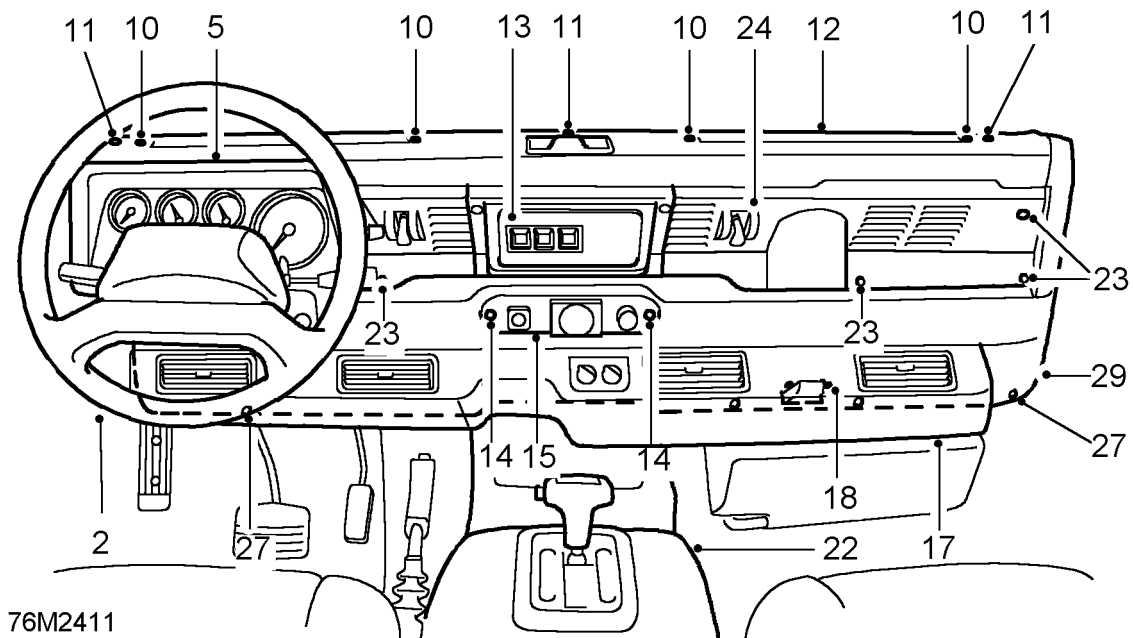

10. Remove 4 screws and remove both demister vents from crash pad.
11. Remove 3 screws securing crash pad to fascia bulkhead.
12. Remove crash pad.
13. Remove rear door switch panel. **See ELECTRICAL, Repair, Switch panel-rear door services**
14. Remove 2 screws, washers and nuts securing auxiliary switch panel to lower fascia panel and switch cover.
15. Withdraw switch panel and disconnect harness leads.
16. Remove 2 screws securing switch cover to parcel tray.
17. Remove air conditioning fascia duct bezel. **See AIR CONDITIONING, Repair, Fascia duct bezel**
18. If air conditioning is not fitted, remove 4 screws and remove both footwell vents from lower fascia panel.
19. Remove single screw and detach door check strap cover from LH and RH doors.
20. Remove 3 screws securing wiper motor cover to fascia bulkhead.
21. Release locating pins from fascia panel, lower wiper motor cover and disconnect instrument illumination switch plug. Retain wiper motor rack cover.
22. Remove centre console. **See Centre console**
23. Prise out 2 large and 5 small cap fasteners securing trim panel to parcel shelf and fascia bulkhead.

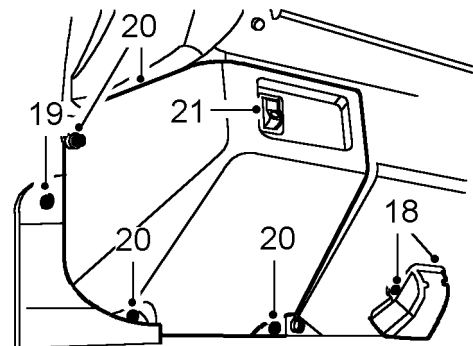

24. Carefully fold back trim panel to clear fresh air vent operating levers and remove panel from parcel shelf.
25. Release demist hose and lift parcel shelf from lower fascia panel (heater duct). Feed main harness leads and plugs through aperture in parcel shelf.
26. Remove parcel shelf.
27. Remove 4 screws securing bottom edge of lower fascia panel to fascia bulkhead, noting position of both footwell cover retaining plates. Remove retaining plates.
28. Unscrew 2 retaining bolts securing top edge of lower fascia panel to bulkhead.
29. With assistance, release lower fascia panel and remove from vehicle.



Refit

30. Position lower fascia panel to bulkhead and secure top edge with 2 bolts.
31. Locate RH footwell cover retaining plate under bottom edge of fascia panel and secure with 3 screws.
32. Repeat operation for LH footwell cover retaining plate.
33. Fit remaining lower fascia panel fixing screws.
34. Locate parcel shelf. Ensure all rear door services and auxiliary switch panel harness leads and plugs are fed through aperture in parcel shelf.
35. Fit demist hoses into heater duct of lower fascia panel. Ensure flanges of hose grommets are correctly seated.
36. Fit trim panel and secure with cap fasteners.
37. Fit centre console. **See Centre console**
38. Reconnect instrument illumination switch plug and locate wiper motor cover pins in lower fascia panel and secure with 3 screws. Ensure wiper rack cover is correctly seated.
39. Fit door check strap covers on both sides.
40. Fit air conditioning fascia duct bezel. **See AIR CONDITIONING, Repair, Fascia duct bezel**
41. If air conditioning is not fitted, fit footwell vents to lower fascia panel.
42. Fit auxiliary switch cover to parcel tray.
43. Connect leads and plugs to auxiliary switches and clock.
44. Secure switch panel to lower fascia panel and switch cover.
45. Fit rear door switch panel. **See ELECTRICAL, Repair, Switch panel-rear door services**
46. Fit crash pad to fascia bulkhead.
47. Fit demister vents in crash pad.
48. Fit grab handle to lower fascia panel and secure to crash pad. Refit Land Rover decal.
49. Connect multi-plugs to rear screen, hazard and interior lamp switches and fit switch panel to fascia panel.
50. Fit heater control cable. **See HEATING AND VENTILATION, Repair, Heater control cable - air distribution**
51. Fit instrument binnacle. **See ELECTRICAL, Repair, Instrument binnacle**
52. Fit steering column nacelle.
53. Fit steering wheel.
54. Reconnect battery.

FRONT WING [FENDER] ASSEMBLY

Service repair no - 76.11.05

Remove

1. Release exterior roll-over bar from its fitted position to allow removal of front wing [fender]. **See exterior roll-over bar**
2. Raise and support front of vehicle on safety stands.
3. Remove road wheel.
4. Disconnect wiring connectors for parking and indicator lamps.
5. Disconnect harness multiplug for headlamp.
6. Position wiring clear of wheel arch.
7. Inside wing [fender] rear: Loosen fully 3 bolts securing wing [fender] bulkhead.
8. Remove 2 bolts securing wheel arch to brackets, front and rear.
9. From inside engine bay: Remove bolt securing rear of wing [fender] to bulkhead.
10. Remove 2 bolts securing wing [fender] to bracket, front bottom.
11. Remove 2 bolts securing wing [fender] to bracket, front top.
12. Lift wing [fender] assembly and disengage rear from 3 bolts and remove.

Refit

13. Ensure washers are against heads of bolts with clearance to insert wing [fender].
14. Position and engage rear of wing [fender] onto bolts.
15. Fit bolts securing top of wing [fender] to front bracket, do not tighten.
16. Fit bolts securing bottom of wing [fender] to front bracket, do not tighten.
17. Fit bolts securing wheel arch to brackets, do not tighten.
18. Position wiring inside wheel arch.
19. Fit bolt securing top of wing [fender] to bulkhead.
20. Align wing [fender] to 'A' post and tighten bolts inside wing [fender] and at top. **25 Nm, 18 lbf ft.**
21. Align front of wing [fender] and tighten bolts at front. **25 Nm, 18 lbf ft.**
22. Tighten bolts inside wheel arch. **25 Nm, 18 lbf ft.**
23. Connect wiring.
24. Fit road wheel and lower vehicle, tighten nuts to **130 Nm, 95 lbf ft.**
25. Fit exterior roll-over bar. **See exterior roll-over bar**

TRIM CASING - FRONT DOOR SOFT TOP

Service repair no - 76.34.01

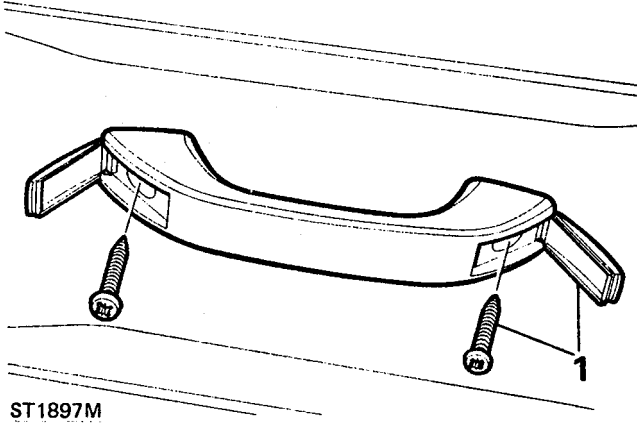
Remove

1. Prise open 2 finishers and remove 2 screws securing door pull.
2. Remove 13 screws securing door trim casing.
3. Release trim casing from door, disconnect wires from speaker and withdraw casing from door handle.

Refit

4. Ensure screw inserts are in door panel or use new inserts. Ensure that anti-vibration pads are in position on trim casing.
5. Position trim casing to door, connect speaker wiring and engage door handle, align fixings in door and secure with screws.
6. Fit door pull, secure with screws and insert finishers.

FRONT DOOR LOCK - SOFT TOP

Service repair no - 76.37.12

Remove

1. Remove door casing. *See Trim casing - front door soft top*

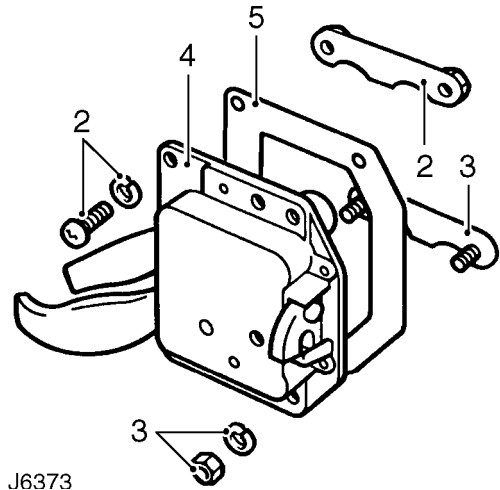

2. Remove 2 screws, washers and nut retainer securing top of lock to door.
3. Remove 2 nuts, washers and screw retainer securing bottom of lock to door.
4. Withdraw lock complete from door panel.
5. Remove door lock gasket.
6. Clean sealant from retainer plates.
7. Insert key into barrel, depress lock barrel plunger and withdraw lock barrel.

Refit

8. Fit new barrel into lock.
9. Apply sealant to lock retainer plates.
10. Fit lock to door with a NEW gasket.
11. Secure with retainer plates, screws, washers and nuts.
12. Close door and check for correct latching with striker.
13. Adjust striker as necessary. *See Adjustment, Door lock striker - adjust*
14. Refit door casing. *See Trim casing - front door soft top*



TAIL DOOR LOCK - SOFT TOP

Service repair no - 76.37.16

Remove

1. Open tail door.

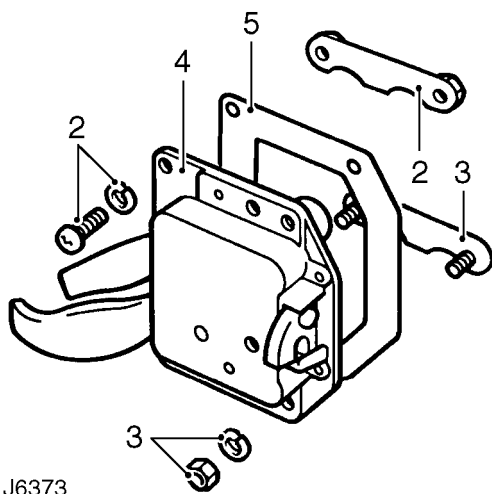

2. Remove 2 screws, washers and nut retainer securing top of lock to door.
3. Remove 2 nuts, washers and screw retainer securing bottom of lock to door.
4. Withdraw lock assembly.
5. Remove door lock gasket.
6. Clean sealant from retainer plates.

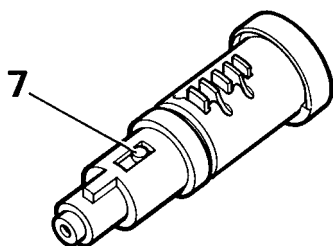

7. Insert key into barrel, depress lock barrel plunger and withdraw barrel from lock.

Refit

8. Fit new barrel into lock.
9. Apply sealant to lock retainer plates.
10. Fit lock to door with a NEW gasket.
11. Secure with retainer plates, screws, washers and nuts.
12. Close door and check for correct latching with striker.
13. Adjust striker as necessary. **See Adjustment, tail door striker - adjust**

PRIVATE LOCK - TAIL DOOR

Service repair no - 76.37.42

Remove

1. Remove tail door lock. **See Door lock - tail door**
2. Insert key in barrel.
3. Depress lock barrel plunger (see ST1979M).
4. Withdraw barrel from lock.

Refit

5. Reverse removal procedure.
6. Refit tail door lock. **See Door lock - tail door**

EXTERIOR ROLL-OVER BAR

Service repair no - 76.11.39

Remove

1. Remove torx bolt, from both sides, securing top of roll-over bar to roof mounted bar.
2. With assistance to support roll-over bar at windscreen, remove 4 torx bolts, from both sides, securing roll-over bar to fender mounting.

3. Remove two torx bolts, from both sides, securing top bar to roof mounting.
4. Slide top bars rearwards to disengage from main roll-over bar assembly.
5. Lift main roll-over bar assembly from vehicle.
6. If necessary, remove 2 torx bolts and nuts, from both sides, and detach lower cross bar from main roll-over bar.

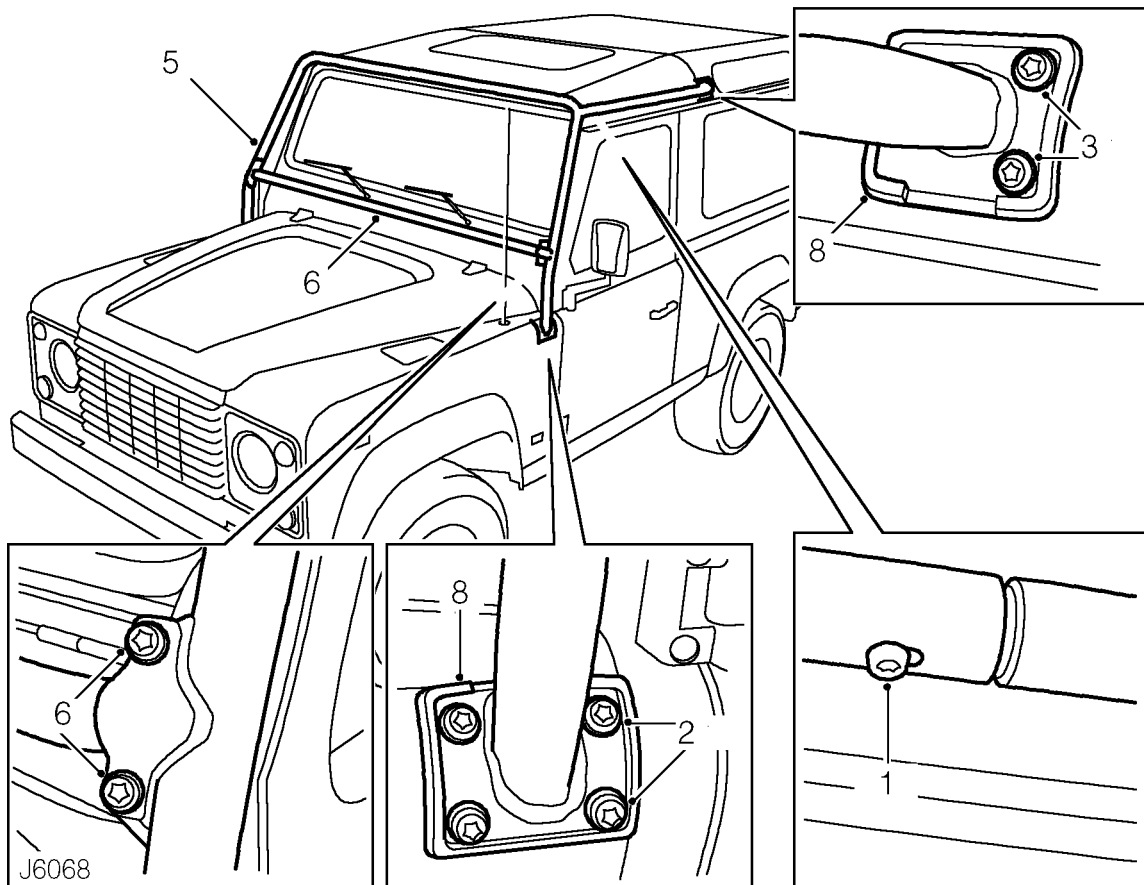
**Refit**

7. Locate lower cross bar into main roll-over bar mounting brackets and secure with torx bolts and nuts to **25 Nm, 18 lbf ft.**
8. Ensure rubber gaskets are fitted correctly to roll-over bar mounting brackets.
9. With assistance, lift roll-over bar assembly and position on fenders.
10. Slide top bars into main roll-over bar, position on roof mounting and secure with torx bolts to **25 Nm, 18 lbf ft.**
11. Secure roll-over bar to both fender mountings with torx bolts. Tighten to **25 Nm, 18 lbf ft.**
12. Secure top bars to main roll-over bar and tighten fixing bolts to **25 Nm, 18 lbf ft.**



INTERIOR ROLL-OVER BAR - HARD TOP

Service repair no - 76.11.40

Remove

1. Remove rear seat squabs. *See rear seat squab*
2. Remove rear end trim panels. *See rear end trim panel - hard top*
3. Remove side trim panels. *See side trim panel - hard top*
4. Remove centre console. *See Centre console*
5. Remove 4 bolts securing centre section of roll-over bar and seat belt stalks to floor. On driver's side, disconnect harness plug connector of audible warning circuit at belt stalk.
6. Remove 2 torx bolts and nuts from both sides and detach centre section of roll-over bar assembly.
7. Remove torx bolt, from both sides, securing roll-over bar to body side mounting brackets.
8. Remove 3 bolts and washers, from both sides, securing lower roll-over bar brackets to front of wheelarch.
9. Remove 2 torx bolts and washers, from both sides, securing roll-over bar upper mountings to roof fixing brackets and carefully lower complete assembly to floor.
10. Unscrew retaining bolts, from both sides, and remove front seat belt inertia reels and rear seat belts from roll-over bar mounting.
11. Supporting from both sides, raise and tilt roll-over bar rearwards to clear wheelarches.
12. Remove roll-over bar from vehicle.



NOTE: Assistance may be required to remove roll-over bar.

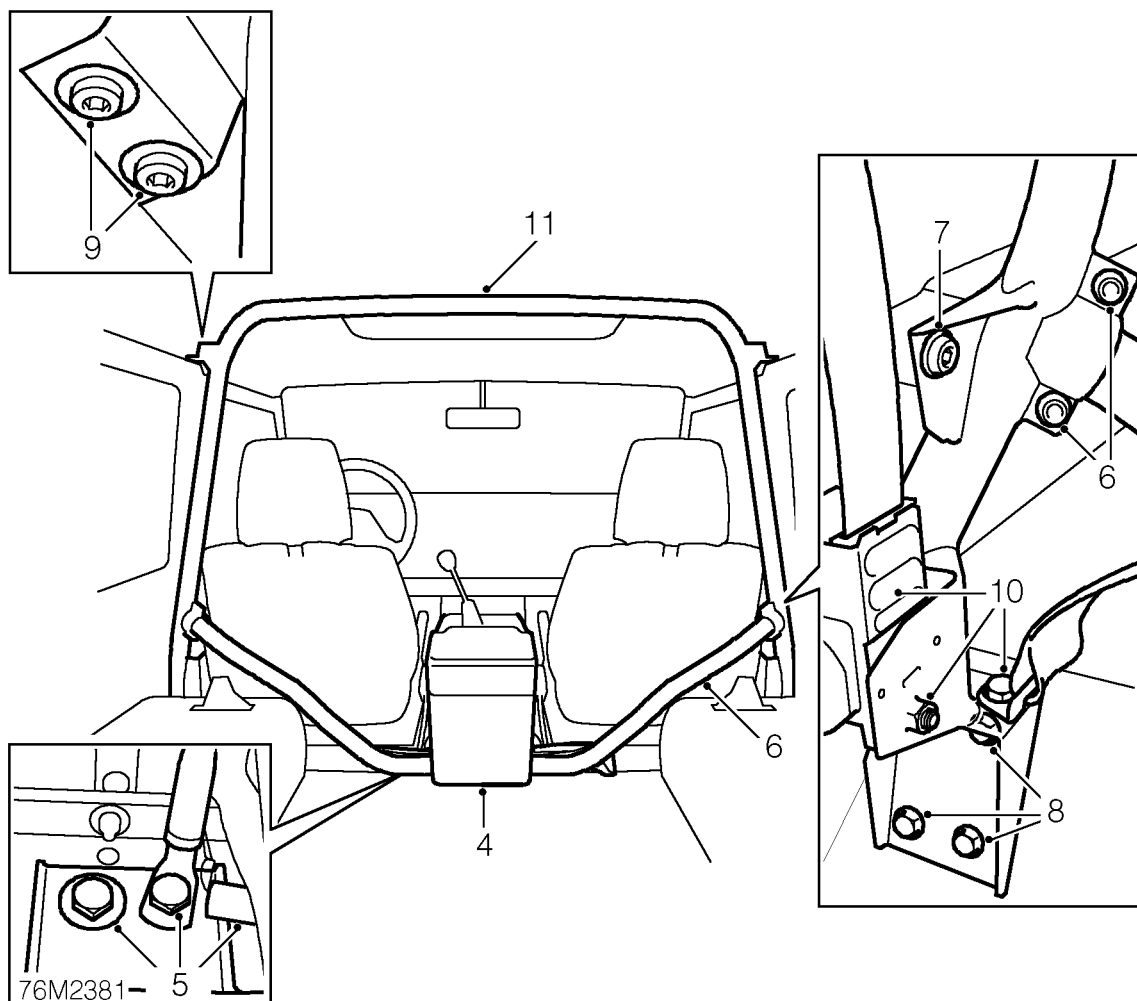

Refit

13. Supporting from both sides, position roll-over bar, engage struts in rear corners and front of side panels. Align on floor.
14. Secure front seat belt inertia reels and rear seat belts to roll-over bar mountings. Tighten bolts to **32 Nm, 24 lbf ft.**
15. Raise roll-over bar assembly and secure to roof mounting brackets. Tighten bolts to **45 Nm, 33 lbf ft.**
16. Secure roll-over bar to wheelarches. Tighten bolts to **45 Nm, 33 lbf ft.**
17. Secure roll-over bar to body side mounting brackets, tightening bolts to **45 Nm, 33 lbf ft.**
18. Secure centre section to main roll-over bar, but do not fully tighten fixing bolts at this stage.
19. Reconnect driver's seat belt audible warning harness plug.
20. Secure seat belt stalks and roll-over bar floor mounting brackets to chassis. Tighten bolts to **32 Nm, 24 lbf ft.**
21. Fully tighten roll-over bar centre section retaining bolts to **45 Nm, 33 lbf ft.**
22. Fit centre console. *See Centre console*
23. Fit side trim panel. *See Side trim panel*

REAR SPEAKER PANEL

Service repair no - 76.13.11

Remove

1. Raise seat cushion and fit stowage strap.
2. Remove rear end trim panel. *See rear end trim panel - hard top*
3. Remove rear speaker. *See ELECTRICAL, Repair, rear speaker*

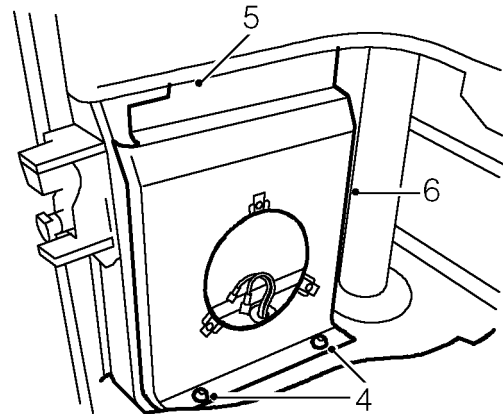

J6051

4. Peel back carpet and remove 2 screws securing speaker panel to wheelarch.
5. Prise top edge of panel down to release from body channel.
6. Remove speaker panel.

Refit

7. Position speaker panel on wheel arch.
8. Press top edge of panel down firmly and locate under body channel.
9. Secure speaker panel to wheel arch with screws and reposition carpet.
10. Fit rear speaker. *See ELECTRICAL, Repair, rear radio speaker*
11. Fit rear end trim panel. *See rear end trim panel - hard top*



WINDSCREEN GLASS

Service repair no - 76.81.01

Remove

1. Remove windscreen wiper arms. **See WIPERS AND WASHERS, Repair, Wiper arm**
2. Remove rear view mirror. **See Interior rear view mirror**
3. Remove 2 screws from each side and release 'A' post finishers.
4. Cover windscreen demist vents with tape to prevent ingress of glass particles.
5. From the outside: Free lip of the sealing rubber from sealant along top of frame and down each side.
6. With an assistant supporting the glass from outside and starting at a top corner, press windscreen glass outwards and release sealing rubber from flange.
7. Remove sealing rubber from glass.



WARNING: If glass has splintered, protect the eyes and use protective gloves.

8. If windscreen has broken, ensure that all particles of glass are removed. Use a vacuum cleaner to remove glass from fascia, carpets and seats.
9. Check frame for distortion and damage to flange, dress and true flange as necessary. Apply primer to any bare metal.
10. Remove particles of glass and examine sealing rubber for cuts and damage, renew as necessary.

Refit

11. Lay glass on felt covered supports, **DO NOT stand on edge.**



CAUTION: Any chipping of glass edge may develop into cracks.

12. Apply a soap solution to glazing channel of sealing rubber.
13. Align sealing rubber to glass and fit by working around glass and easing sealing lips over glass edge.
14. Insert a cord around the flange channel of sealing rubber so that ends cross over at the bottom.
15. Apply a soap solution around sealing rubber to aid fitment.
16. Place glass assembly against frame ensuring sealing rubber has equal overlap all round with draw cord over bottom of flange.
17. Assistant from outside, press sealing rubber firmly against flange and use cord to pull lip of seal over flange.
18. Carefully work around sealing rubber and equalize seal to glass and flange.
19. Apply a bead of windscreen sealant under outside sealing lip, along each side and across the top.
20. Fit rear view mirror. **See Interior rear view mirror**
21. Fit 'A' post finishers.
22. Remove tape from demist vents.
23. Fit windscreen wiper arms. **See WIPERS AND WASHERS, Repair, Wiper arm**

REAR TOW BAR

Service repair no - 76.11.41

Remove

1. Remove bolt, washer and nut from both sides, securing tow bar lower mounting brackets and towing [fender] eyes to chassis.

2. Remove 4 bolts and spring washers securing tow bar centre mounting bracket to chassis.
3. Remove both bolts securing 2 tow bar locating tubes in rear chassis cross member.
4. Remove 2 bolts securing tow bar top mounting brackets to chassis.
5. With assistance, withdraw tow bar assembly from chassis.

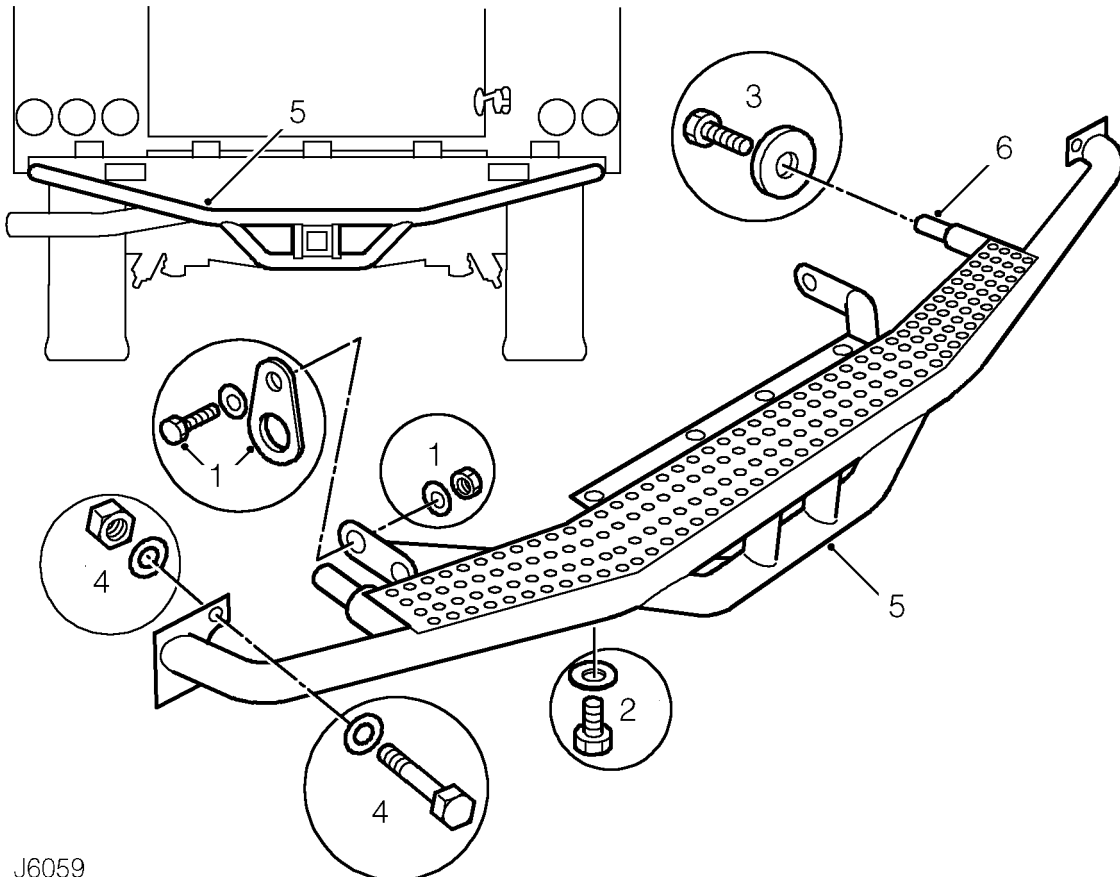

J6059

Refit

6. With assistance, lift tow bar assembly and locate both tubes in chassis crossmember.
7. Secure top tow bar mounting brackets to chassis but do not fully tighten fixings.
8. Secure tow bar locating tubes to rear of chassis and tighten bolts to **25 Nm, 18 lbf ft.**
9. Secure tow bar centre mounting bracket to underside of chassis and tighten bolts to **25 Nm, 18 lbf ft.**
10. Position towing [fender] eyes to lower mounting brackets and secure to chassis and tighten bolts to **25 Nm, 18 lbf ft.**
11. Fully tighten tow bar top mounting bracket bolts to **25 Nm, 18 lbf ft.**



BONNET

Service repair no - 76.16.01/99

Remove

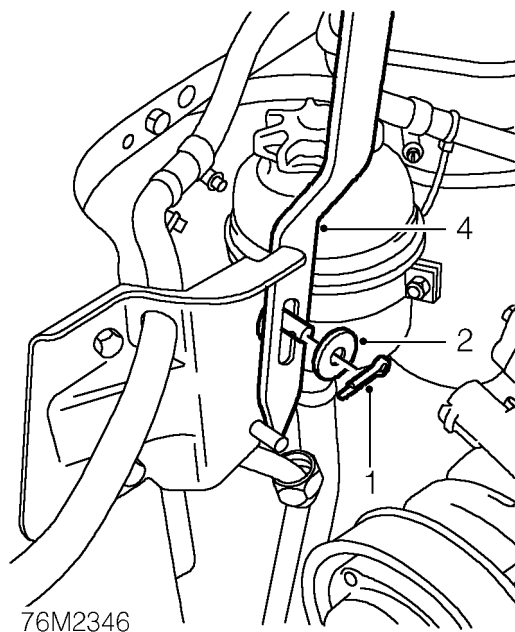

76M2346

1. Remove split [cotter] pin from bonnet prop lower pivot.
2. Remove washer and anti-rattle washer from pivot.
3. Position suitable chock to support bonnet in a position to gain access to hinge nuts.
4. Release bonnet prop from pivot, fold prop up into bonnet and rest bonnet onto chock.

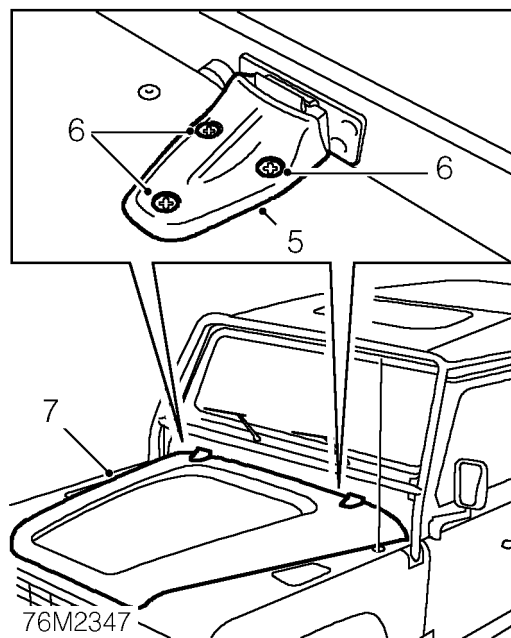

76M2347

5. Mark outline of hinge on bonnet.
6. Remove 6 nuts and screws securing bonnet to hinges.
7. With assistance, remove bonnet.

Refit

8. With assistance, position bonnet to hinges.
9. With assistance, fit screws through hinges and bonnet and fit washers and nuts to screws.
10. Align hinges to bonnet markings.
11. Tighten hinge retaining screws.
12. Raise bonnet from chock and connect prop to pivot.
13. Fit anti-rattle and plain washers to pivot and secure with split [cotter] pin.
14. Release prop and close bonnet to check alignment and operation.

CENTRE CONSOLE**Service repair no - 76.25.01****Remove**

1. Open cubby box lid.
2. Remove in-car entertainment unit - if fitted.

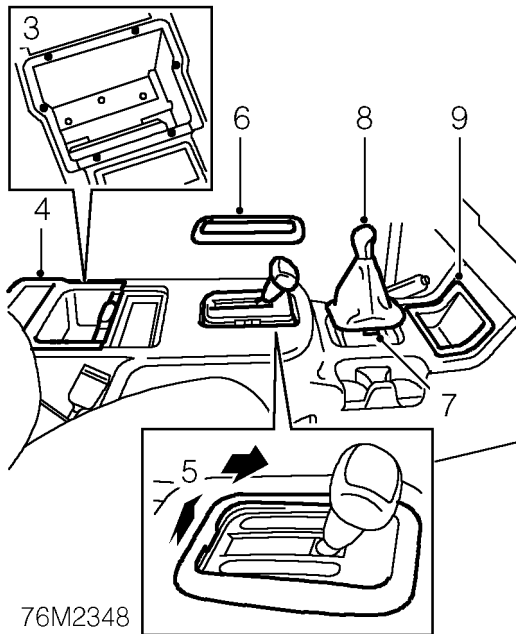

76M2348

3. Remove 6 screws securing cubby box to console.
4. Remove cubby box.
5. Release rear edge of selector housing surround.
6. Remove surround.
7. Release hi-low gear lever gaiter from console.
8. Remove hi-low gear lever knob and gaiter assembly.
9. Remove tray from console.
10. Remove screw securing front edge of console.
11. Remove 3 screws securing rear of console.
12. Remove console.

Refit

13. Fit and align console.
14. Fit and tighten screws securing console.
15. Fit tray to console.
16. Fit hi-low gear lever knob and gaiter assembly.
17. Secure hi-low gear lever gaiter to console.
18. Fit gear selector housing surround and secure.
19. Fit cubby box to console and secure with screws.
20. Fit in-car entertainment unit - if fitted.
21. Close cubby box lid.



RADIATOR GRILLE

Service repair no - 76.55.03

Remove

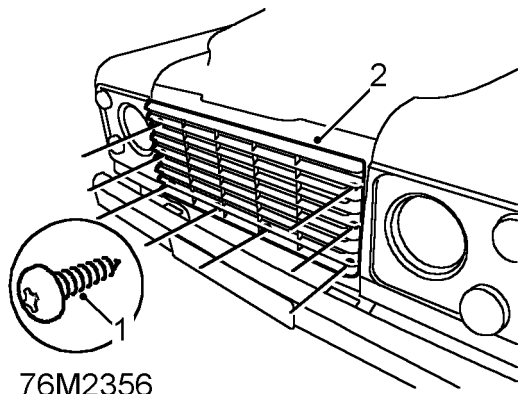

1. Remove 8 screws securing grille to front panel.
2. Remove radiator grille

Refit

3. Position radiator grille to front panel.
4. Secure grille with screws.

GRILLE PANEL

Service repair no - 76.55.06

Remove

1. Remove radiator grille. **See radiator grille**
2. Disconnect multiplug from condenser fan fly-lead.
3. Loosen bolts securing top panel and grille panel to fenders.
4. Remove bolts securing grille panel to fenders.
5. Remove grille panel.

Refit

6. Position grille panel and fit bolts to fender, finger tight.
7. Fit plastic nuts to lower fixing, each side
8. Fit screws to top panel.
9. Align grille panel and tighten all fixings.
10. Fit radiator grille. **See radiator grille**

CANOPY ASSEMBLY

Service repair no - 76.61.11

Remove

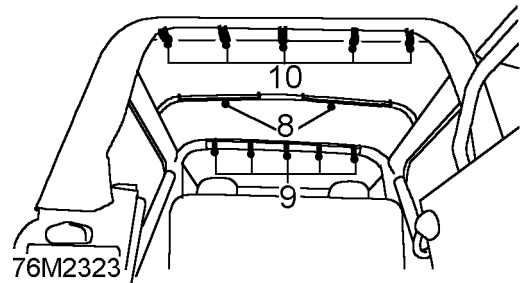
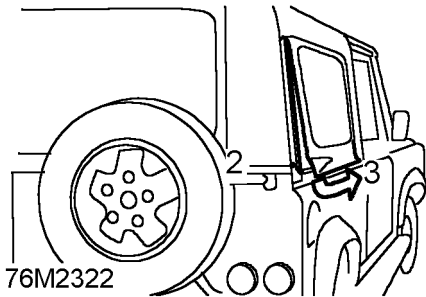

1. Release side window velcro strips, each side and top.
2. Unzip side window panels, at side only.
3. Release retaining batten from bottom channel.

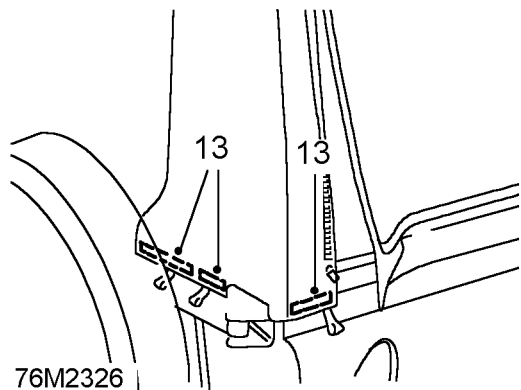
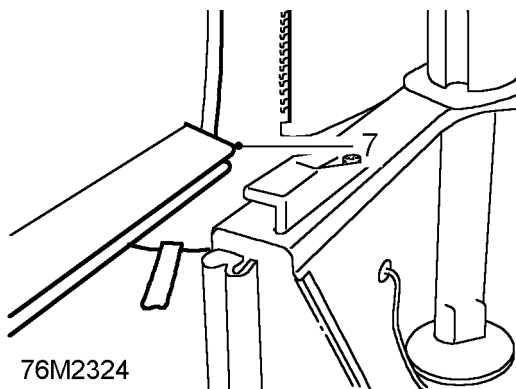
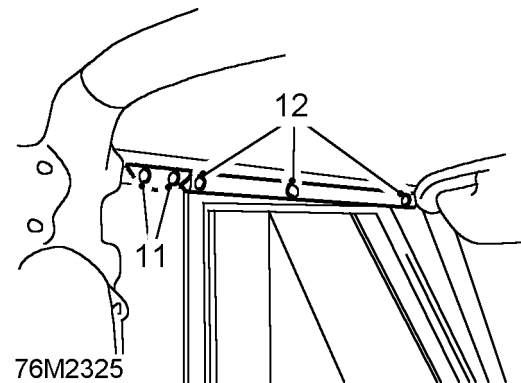

4. Open rear door.
5. Release velcro strips each side of rear window.
6. Unzip rear window panel, down each side.
7. Release retaining bar, each end of rear window.
8. Release velcro strips securing 2 flaps to roof bow.
9. Release 5 press studs securing flap around centre roll-over bar.
10. Release 5 press studs securing straps around rear roll-over bar.
11. Open front doors. Release 2 press studs securing flaps, forward of centre roll-over bar.
12. Release 3 press studs securing flaps to frame above front doors.
13. Release 3 canopy battens from channels at each rear corner panel.
14. Release canopy batten from channel on each side panel.

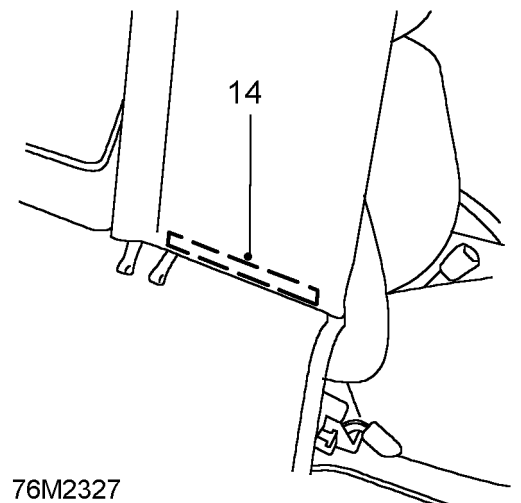

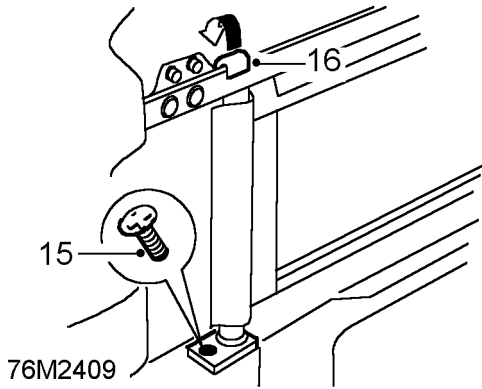

Hood Canopy

G2

- 15. Remove screw securing side panel support rod to vehicle body on each side.
- 16. Unhook top end of rods from support bars.

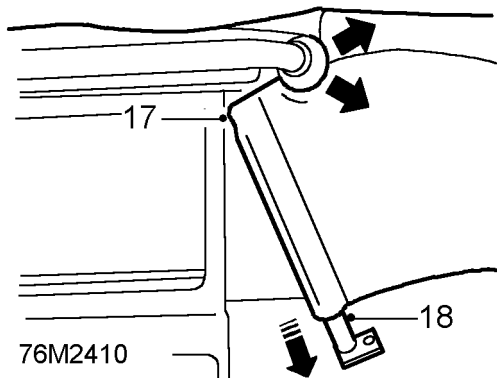

- 17. Remove top of side panels from groove in side bar mouldings.
- 18. Withdraw support rods from pockets in side panels.

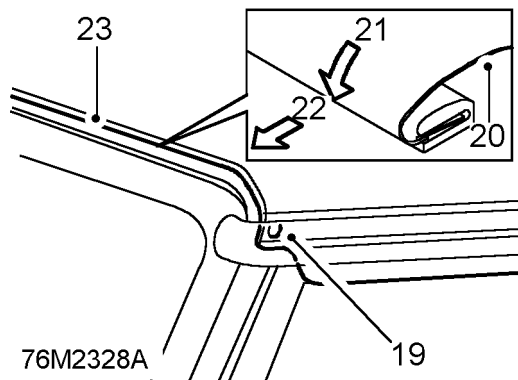

- 19. Release 2 press studs securing canopy to each end of windscreen frame.
- 20. Pull canopy forward to release tension.

- 21. Release batten from channel above windscreen and ease downwards to clear.
- 22. Ease front of canopy up between frame and roll-over bar brackets.
- 23. Fold front of canopy onto roof.
- 24. Fold rear panel onto roof of canopy.
- 25. Fold each side panel onto roof.
- 26. Fold side and rear corner panels onto roof.
- 27. Remove canopy from vehicle.

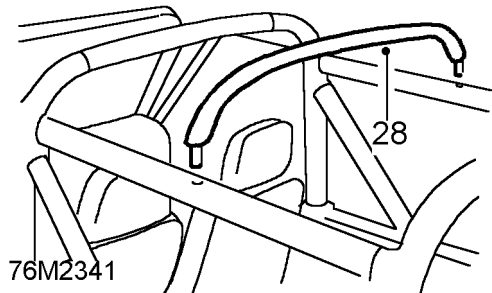

- 28. Remove intermediate roof bow, retained by spring loaded ball each side.

Refit

- 29. Lubricate spigots and fit intermediate bow to cant rails.
- 30. Position canopy across centre roll-over bar and roof bow.
- 31. Unfold canopy, position loosely over roll-over bars and centralise.
- 32. Pull forward and position retaining batten between windscreen frame and roll-over bar.
- 33. Ease batten upwards, rotate and engage channel, press ends down and fully into channel.
- 34. Fasten front of canopy with press studs.
- 35. Pull canopy to tension over rear roll-over bar.
- 36. Fasten press studs securing canopy to rear roll-over bar.
- 37. Feed cut-out in top of side panel into groove around roll-over bar moulding.
- 38. Fasten press studs securing front sides to support bars.
- 39. Fasten press studs securing canopy to centre roll-over bar.
- 40. Secure flaps to roof bow.
- 41. Fully tension straps securing canopy to rear roll-over bar.
- 42. If side windows have been removed: Zip side windows along top only.
- 43. Engage side window zips at each side, do up 50 mm, 2 in only.

44. Pull down on rear panels and engage battens by pressing firmly into place.



NOTE: Use a 'T' handled hook to pull down on the loops to ease batten engagement.

45. Fasten side window zips and secure velcro strips.
46. Fit rear window retaining bar, fasten rear window zips and secure velcro strips.



HEATING AND VENTILATION SYSTEM

Description

The heating and ventilation system is standard on all models. Air conditioning is an optional system which provides fully integrated climate control for the vehicle interior.

The heater assembly, comprising a matrix housed in a distribution unit and a variable speed blower motor, is located on one side of the engine compartment and attached directly to the fascia bulkhead.

The heating controls are positioned on the outside of the instrument binnacle and cable linked to mechanical flaps in the distribution unit.

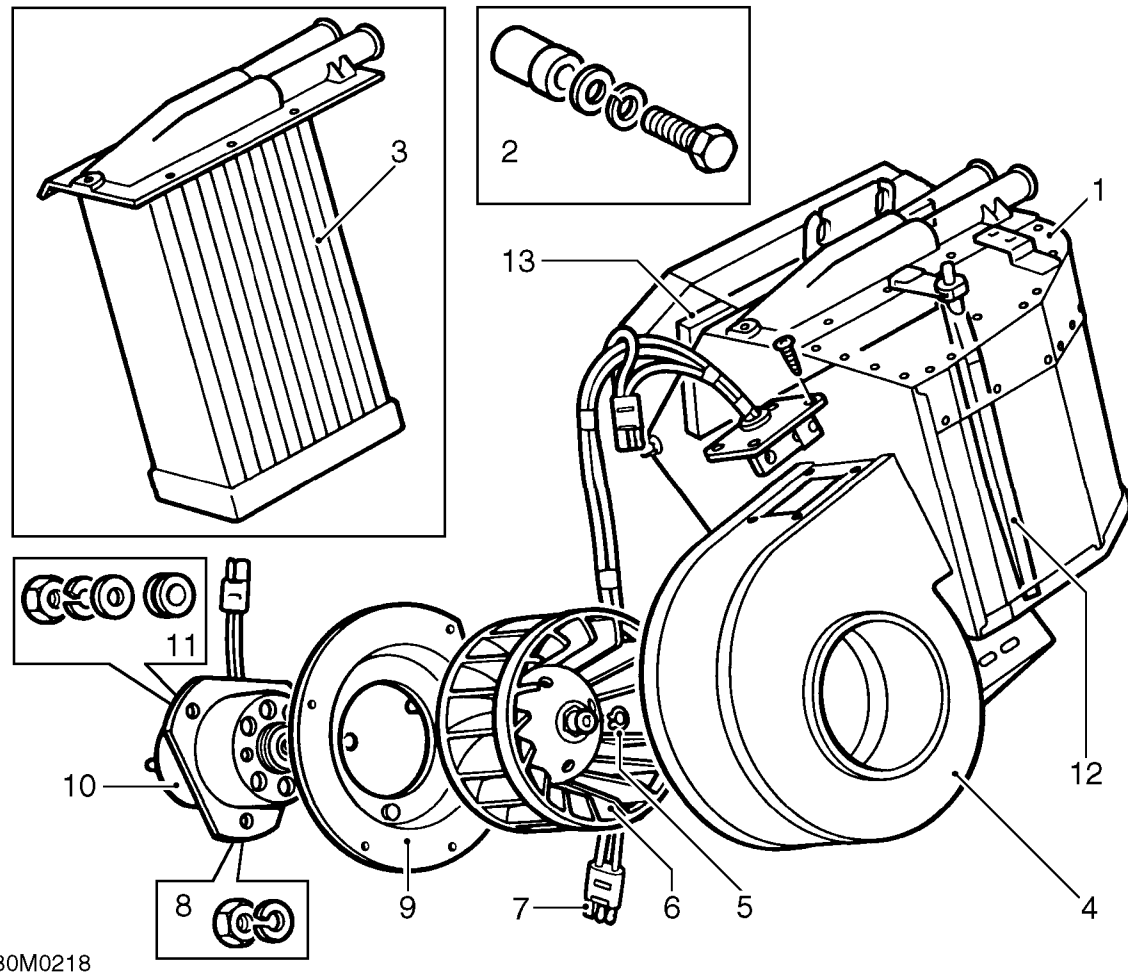

Heater assembly

- | | |
|--|--|
| 1. Heater distribution unit | 8. Fixings, blower motor mounting plate |
| 2. Fixings, heater to fascia bulkhead | 9. Mounting plate, blower motor |
| 3. Heater matrix | 10. Blower motor |
| 4. Blower motor housing | 11. Fixings, blower motor to mounting bracket |
| 5. Circlip, impeller to blower motor | 12. Temperature flap, air flow to heater matrix |
| 6. Impeller | 13. Air flap, air supply to plenum chamber (heater duct) |
| 7. Resistor unit and harness connector | |

HEATER OPERATION

The heater matrix, located in the distribution unit, is connected to the engine cooling system. As coolant is circulated continuously through the matrix, a selection of heated or ambient air is controlled by two flaps within the distribution unit. The temperature flap controls the amount of ambient air to the heater matrix, air being supplied

through a ducted vent on top of the vehicle front wing to the blower motor (volute) housing. The blower motor can be used to boost the air flow into the distribution unit. The air flap controls the supply of heated or ambient air from the heater unit into a plenum chamber integral with the vehicle fascia. Two flaps in the plenum chamber (heater duct) distribute the air flow to either the footwell vents or windscreen demister vents.

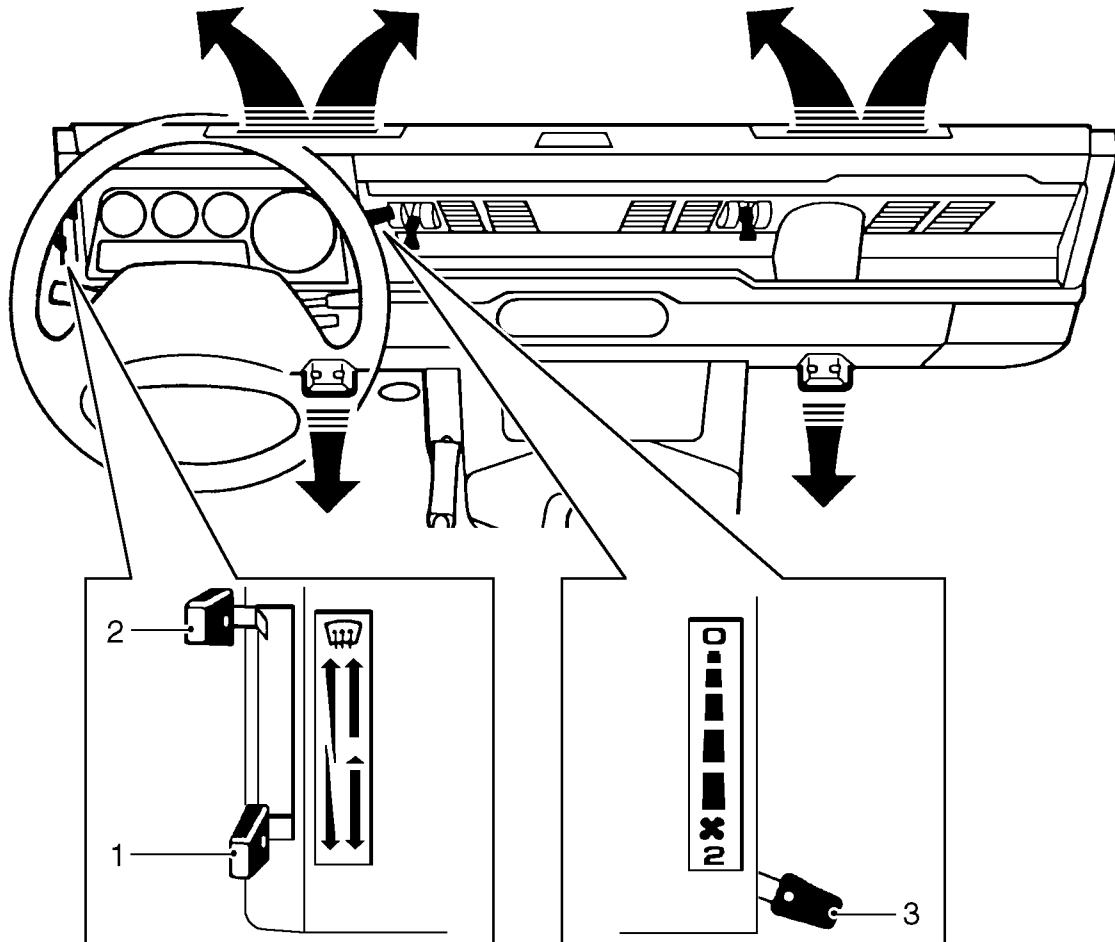

80M0219

Non air conditioning fascia shown

Heater controls

1. Temperature control

Move the lever downwards to increase air temperature or up to decrease air temperature.

2. Air distribution control

Lever fully up - windscreen vents only.
Lever midway - footwell and windscreen vents.
Lever fully down - footwell vents.

3. Blower motor fan speed control

Move the lever progressively downwards to increase fan speed. With the control at 'O' the fan is switched off and the volume of air entering the passenger compartment is solely dependent on ram effect when the vehicle is moving forward.



Fresh air vents

Two fresh air vents are fitted in the windscreen frame and are controlled independently of the vehicle heating system. Each vent is operated separately.

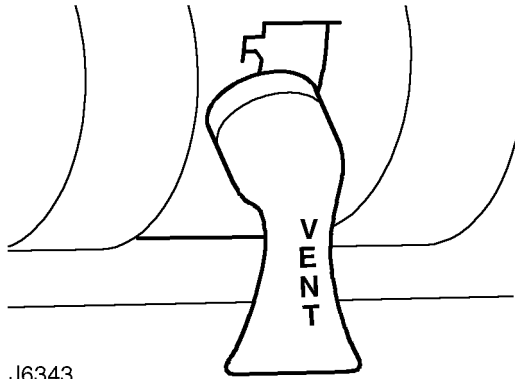

To open a vent, push the lever to the right and then to the required position.



HEATER UNIT

Service repair no - 80.20.01

Remove

1. Remove bonnet and disconnect battery.
2. Remove radiator bottom hose at radiator union and drain cooling system. **See COOLING SYSTEM, Adjustment, Drain and refill**

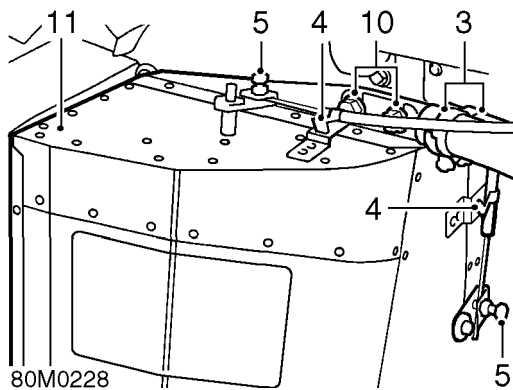

3. Slacken clips and disconnect heater hoses at heater box unions.
4. Remove outer cable securing clips.
5. Slacken trunnions and disconnect control cables from heater vent flap levers.
6. Remove heater wiring harness securing loop.
7. Disconnect harness multi-plug.
8. Remove interior bulkhead trim.
9. Remove lower nuts and bolts securing the heater unit to the bulkhead. If air conditioning is fitted, remove evaporator. **See AIR CONDITIONING, Repair, Evaporator**
10. Slacken heater unit upper retaining bolts.
11. Manoeuvre heater unit, complete with blower motor, clear of air inlet duct and remove from engine compartment.

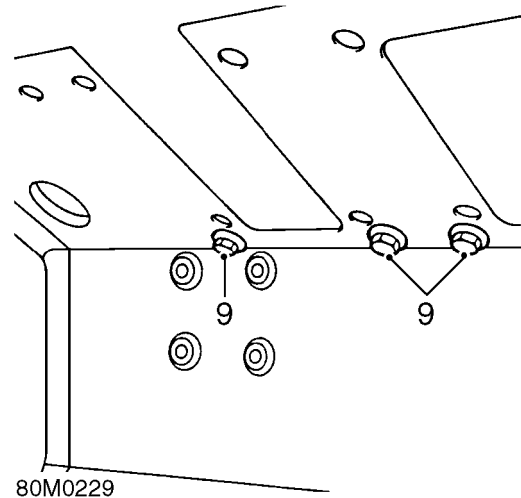

12. Remove sealing rubber.

For heater matrix removal. **See Heater matrix**
For blower motor removal. **See Blower motor**

Refit

13. Smear a NEW sealing rubber with a suitable impact adhesive and fit to heater unit.
14. Manoeuvre heater unit into position in engine compartment, fit blower motor to air inlet duct and locate upper fixing bolts.
15. Loosely fit lower fixing bolts to heater unit .
16. Fully tighten upper fixing bolts followed by the lower fixings.
17. Refit interior bulkhead trim.
18. Secure wiring harness and reconnect multi-plug.
19. Fit control cables to vent flap trunnions and secure with outer cable clips.
20. Connect heater hoses.
21. Fit radiator bottom hose and refill cooling system. **See COOLING SYSTEM, Adjustment, Drain and refill**
22. If air conditioning is installed, fit evaporator. **See AIR CONDITIONING, Repair, Evaporator**
23. Fit bonnet and reconnect battery.

BLOWER MOTOR

Service repair no - 80.20.15

Remove

1. Remove heater unit. *See Heater unit*
2. Remove 3 nuts securing angled bracket to heater unit. Pivot bracket to remove from studs.

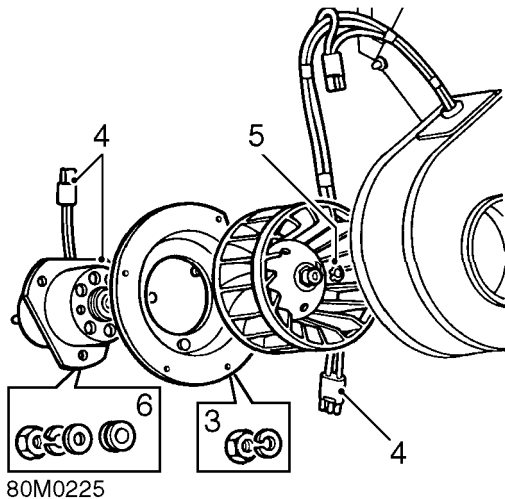

3. Remove 5 nuts securing blower motor assembly to volute housing.
4. Disconnect harness connector and remove blower motor from volute housing.
5. Release circlip and withdraw impeller from motor drive shaft.
6. Remove 3 nuts securing blower motor to mounting plate.
7. Remove blower motor.
8. Examine components for signs of wear and renew as necessary.

Refit

9. Apply Bostik 1261 adhesive to mating faces of mounting plate and blower motor.
10. Fit blower motor to mounting plate and secure with nuts. Ensure rubber mountings are correctly fitted.
11. Fit impeller to motor drive shaft and secure with circlip.
12. Position blower motor assembly in volute housing and secure with nuts. Fit angled bracket to lower fixing.
13. Reconnect harness plug to resistor harness and fit angled bracket to heater unit.
14. Fit heater unit. *See Heater unit*

HEATER MATRIX

Service repair no - 80.20.29

Remove

1. Remove heater unit. *See Heater unit*

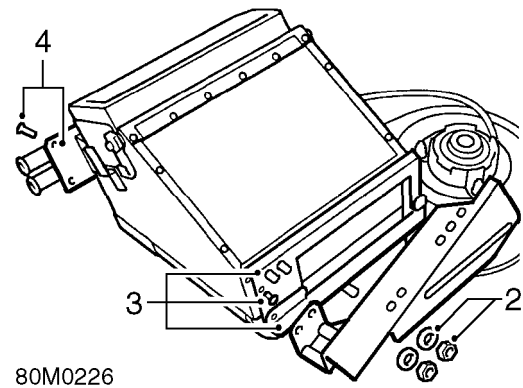

2. Remove 3 nuts securing angled bracket to heater unit. Pivot bracket to remove from studs.
3. Remove 14 screws and detach 2 matrix retaining plates from heater unit base.
4. Remove 9 screws securing matrix top retaining plate.

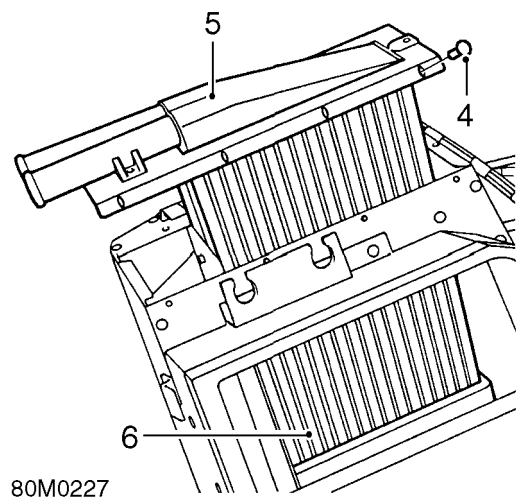

5. Withdraw heater matrix through top of heater unit casing.

**Refit**

6. Fit foam rubber to heater matrix casing.
7. Position matrix in heater unit casing.
8. Check that both vent flaps operate correctly without sticking.
9. Secure matrix top retaining plate.
10. Secure matrix bottom retaining plates.
11. Fit heater unit. **See Heater unit**

RESISTOR UNIT

Service repair no - 80.20.17

Remove

1. Remove heater unit. **See Heater unit**

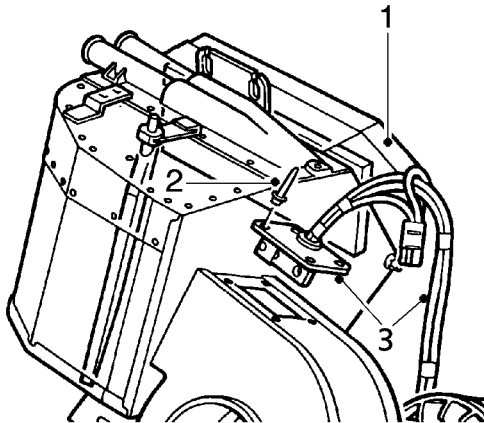

80M0259

2. Drill out 4 rivets securing resistor mounting plate to top of volute housing.
3. Remove resistor and disconnect blower motor plug from harness.

Refit

4. Apply Bostik adhesive to resistor mounting plate and rivet to volute housing.
5. Reconnect blower harness motor plug.
6. Fit heater unit. **See Heater unit**

HEATER CONTROL CABLE - TEMPERATURE CONTROL

Service repair no - 80.10.05

Remove

1. Disconnect battery.

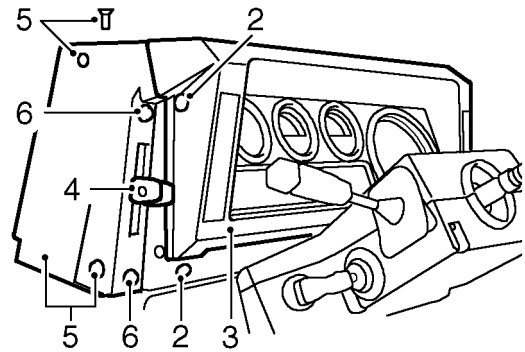

80M0230

2. Remove 4 screws securing instrument binnacle to fascia cowl.
3. Pull instrument binnacle away from fascia to ease access to control cable at bulkhead.
4. Remove retaining screws and pull off air distribution and temperature control lever knobs.
5. Remove 3 screws and detach side cover, complete with control lever assembly.

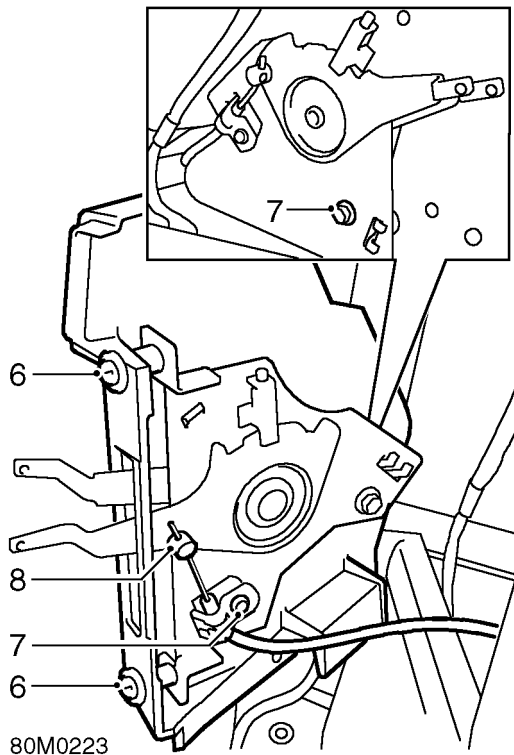

80M0223

6. Remove 2 screws securing control lever assembly to side cover and remove cover. Retain plastic screw spacers fitted between cover and control lever assembly.
7. Remove bolt and release outer cable retaining clip.
8. Slacken grub screw and release inner cable from clevis.

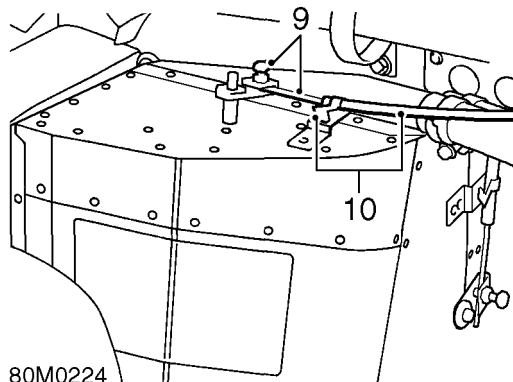

80M0224

9. From inside engine compartment: Release outer cable retaining clip at heater unit.
10. Slacken trunnion fixing and release inner cable from heater unit flap lever.

11. Release 2 retaining clips securing control cables to engine bulkhead.
12. Pull control cable through bulkhead grommet and remove from vehicle.

Refit

13. Fit control cable to heater flap lever trunnion with approximately 10 mm, 0.4 in of inner cable protruding from trunnion. Fully tighten trunnion.
14. Secure outer cable with retaining clip.
15. Route control cable through sealing grommet and along inside of engine bulkhead to fascia binnacle.
16. Secure control cables to engine bulkhead with retaining clips.
17. With control lever in closed position, fit inner cable to lever clevis and fully tighten clevis grub screw.
18. Fit outer cable retaining clip and fully tighten securing bolt.
19. Fit side cover to control lever assembly. Ensure fixing screw spacers are positioned between cover and lever assembly.
20. Fit side cover to fascia.
21. Fit control lever knobs.
22. Fit instrument binnacle.
23. Reconnect battery.



HEATER CONTROL CABLE - AIR DISTRIBUTION

Service repair no - 80.10.12

Remove

1. Disconnect battery.
2. Remove steering wheel.

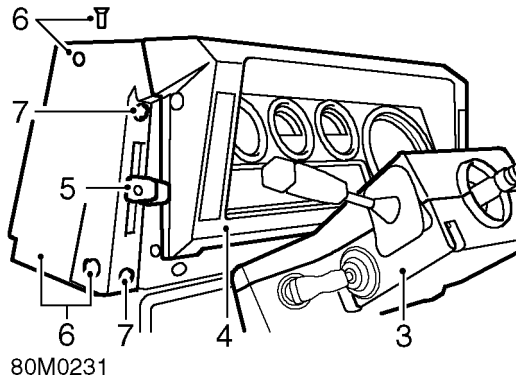

3. Remove steering column nacelle.
4. Remove instrument panel. **See INSTRUMENTS, Repair, Instrument panel**
5. Remove retaining screws and pull off air distribution and temperature control lever knobs.
6. Remove 3 screws and detach side cover, complete with control lever assembly.

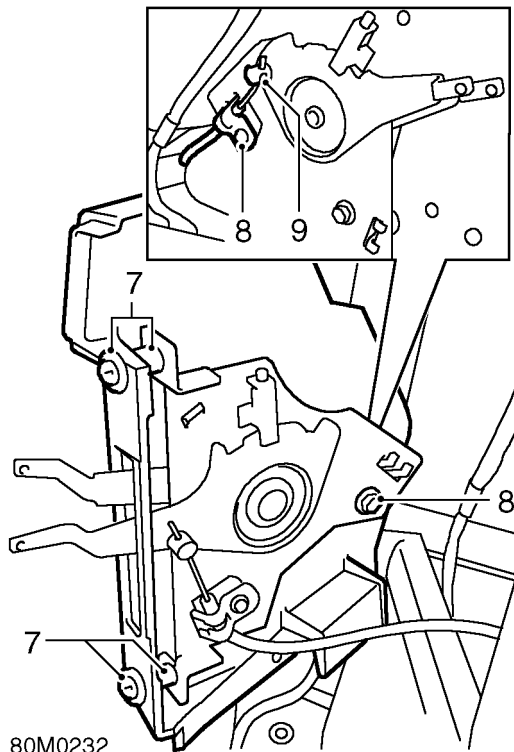

7. Remove 2 screws securing control lever assembly to side cover and remove cover. Retain plastic screw spacers fitted between cover and control lever assembly.
8. Remove bolt and release outer cable retaining clip.
9. Slacken grub screw and release inner cable from clevis.
10. Remove heater duct assembly. **See CHASSIS AND BODY, Repair, Heater duct assembly**

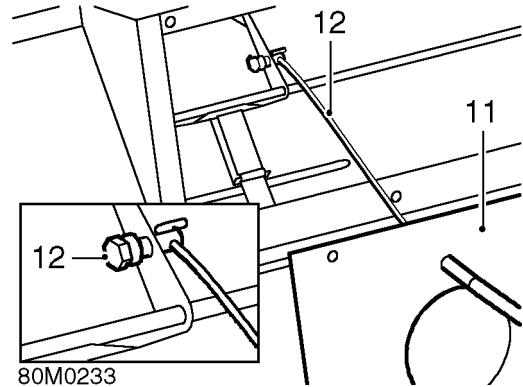

11. Remove 19 screws and lift off heater duct cover.
12. Slacken vent flap trunnion fixing, release air distribution control cable and remove from heater duct.
13. Check condition of foam sealant on heater duct cover and renew if necessary.

Refit

14. Fit control cable through heater duct cover and secure to vent flap trunnion. Bend over cable end to fully secure.
15. Fit heater duct cover.
16. Fit heater duct assembly to fascia bulkhead. **See CHASSIS AND BODY, Repair, Heater duct assembly**
17. Route control cable along fascia bulkhead to control lever assembly.
18. With control lever in closed position, secure cable to clevis.
19. Fit outer cable retaining clip to lever assembly.
20. Fit lever assembly to side cover. Ensure screw spacers are fitted between cover and lever assembly.
21. Fit side cover to fascia cowl.
22. Fit control lever knobs.
23. Fit instrument panel. **See INSTRUMENTS, Repair, Instrument panel**
24. Fit steering column nacelle.

CONTROL CABLE AND BLOWER MOTOR SWITCH

Service repair no - 80.10.17 - Control cable

Service repair no - 80.10.22 - Blower motor switch

Remove

1. Disconnect battery.

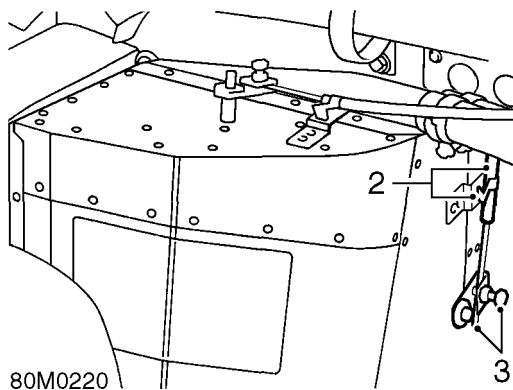

2. From inside engine compartment, release outer cable retaining clip at heater unit.
3. Slacken trunnion fixing and release inner cable from heater unit flap lever.
4. Release 2 retaining clips securing control cables to engine bulkhead and heater hoses.

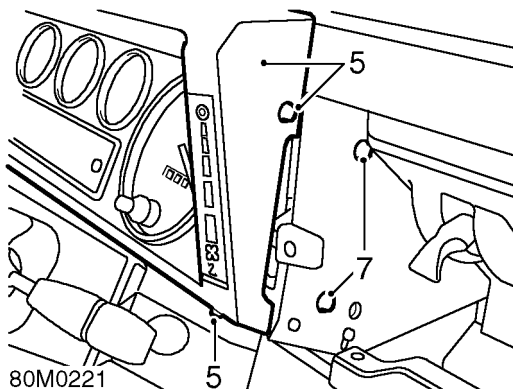

5. Remove 4 screws securing instrument panel to fascia cowl.
6. Pull instrument binnacle away from fascia to ease access to control cable.
7. Remove 2 screws securing control lever assembly to side of fascia binnacle cowl. Retain plastic screw spacers fitted between cowl and lever assembly.

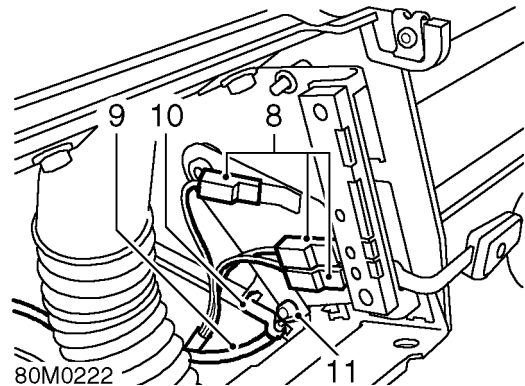

8. Release lever assembly and disconnect 3 blower motor leads, noting their positions.
9. Pull control cable through bulkhead grommet and out from instrument binnacle cowl.
10. Release retaining clip securing outer cable to lever assembly.
11. Release inner cable from lever peg.



NOTE: Renew complete lever assembly if the blower motor switch is faulty.

Refit

12. Fit control cable to lever assembly peg.
13. Fit retaining clip to secure outer cable.
14. Reconnect blower motor leads.
15. Route cable to rear of instrument panel cowl, along bulkhead and out through grommet into engine compartment.
16. Fit lever assembly to instrument panel cowl. Ensure screw spacers are fitted between cowl and lever assembly.
17. Fit instrument binnacle to fascia cowl.
18. With lever in closed position, fit control cable to heater unit flap lever trunnion.
19. Secure outer cable with retaining clip.
20. Secure control cables to engine bulkhead and heater hoses with retaining clips.
21. Reconnect battery.



SCHEMATIC LAYOUT OF THE AIR CONDITIONING SYSTEM

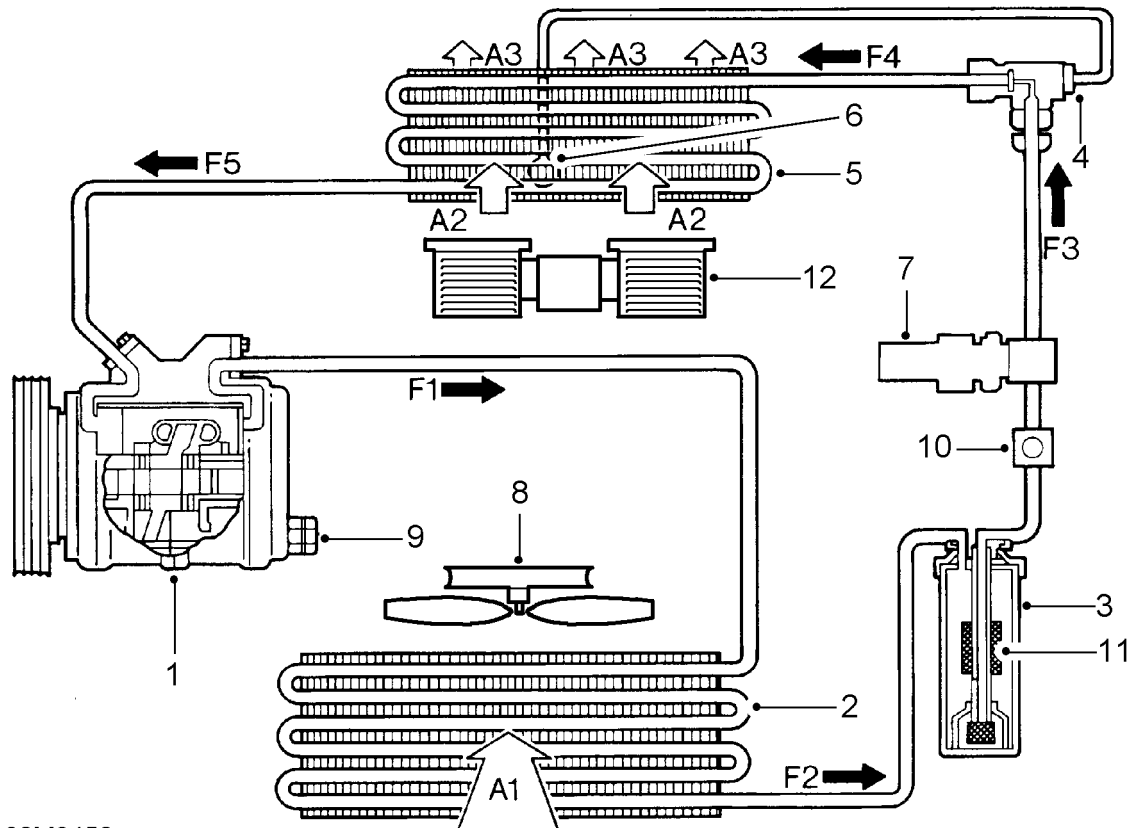

82M0452

- | | |
|---|---|
| <ul style="list-style-type: none"> 1. Compressor 2. Condenser 3. Receiver/drier 4. Thermostatic expansion valve 5. Evaporator 6. Capillary tube 7. Trinary pressure switch 8. Condenser cooling fan - single only 9. Compressor high pressure relief valve 10. Sight glass - refrigerant 11. Drying agent - receiver/drier 12. Blower motor | <ul style="list-style-type: none"> A1 Ambient air flow through condenser A2 Recirculatory air flow through fan and evaporator A3 Cooled air flow to vehicle interior F1 High pressure high temperature refrigerant vapour F2 High pressure slightly subcooled refrigerant liquid F3 High pressure slightly subcooled refrigerant liquid with moisture, vapour bubbles and foreign matter removed F4 Low pressure low temperature mixed liquid and vapour F5 Low pressure slightly super heated refrigerant vapour |
|---|---|

AIR CONDITIONING SYSTEM OPERATION

The air conditioning system provides the means of supplying cooled and dehumidified, recirculated air to the interior of the vehicle. The cooling effect is obtained by blowing air through the matrix of an evaporator unit which has a variable temperature control to provide the conditions required inside the vehicle. The volume of cooled air supplied is controlled by a variable speed blower.

A sealed system, charged with Refrigerant R134a, together with a blower unit and evaporator temperature control combine to achieve the cooled air condition.

The air conditioning system comprises six major units:

1. An engine-mounted compressor.
2. A condenser mounted in front of the radiator.
3. A receiver/drier unit mounted on RH front valance.
4. Thermostatic expansion valve mounted in front of the evaporator.
5. An evaporator and blower unit mounted under the RH side of the fascia panel.
6. Blower and temperature control switches.

These units are interconnected by hoses and pipes carrying **Refrigerant R134a**, the evaporator is separate from the vehicle ventilation system.

Refrigeration cycle

1. Compressor

The compressor (1), belt driven from the crankshaft pulley, is brought into operation by an **AC** switch on the fascia which when selected engages an electro-magnetic clutch to operate the compressor, which pressurises and circulates the refrigerant through the system. The electro-mechanical clutch maintains the correct temperature and pressure by engaging or disengaging to support the system's requirements. The clutch action is normally controlled by a thermostat located at the evaporator (5). The compressor is of the swashplate type, having fixed displacement.

Should the temperature at the evaporator (5) fall low enough for ice to begin to form on the fins, the thermostat disengages the clutch and also isolates the cooling fans relays. When the temperature at the evaporator rises to the control temperature, the clutch is re-engaged.

Should the system pressure become excessive or drop sufficiently to cause damage to the compressor (1) a trinary pressure switch (7), located in the high pressure line, signals the relay unit to disengage the clutch. The compressor also has an emergency high pressure relief valve (9) fitted.

The condenser cooling fan operates continuously when air conditioning is selected.

2. Condenser

From the compressor, hot high pressure vaporised refrigerant (F1) passes to the condenser (2), which is mounted in front of the engine coolant radiator. Ram air (A1) passing through the condenser (2), supplemented by the cooling fan (8) mounted in front of the condenser, cools the refrigerant vapour sufficiently to form a high pressure slightly subcooled liquid (F2).

3. Receiver/drier

This liquid then passes to a receiver/drier (3) which fulfils two functions. It acts as a reservoir and moisture extractor (11).

A sight glass (10), in the high pressure line, provides a method of determining the state of the refrigerant without breaking into the system.

4. Expansion valve

From the receiver/drier (3) the moisture free high pressure liquid refrigerant (F3) passes through a thermostatic expansion valve (4). A severe pressure drop occurs across the valve and as the refrigerant enters the evaporator space at a temperature of approximately -5°C , 23°F it boils and vaporises.



5. Evaporator

As this change of state occurs, a large amount of latent heat is absorbed. The evaporator is therefore cooled and as a result heat is extracted from the air flowing across the evaporator. The air flow is controlled by the blower fans which can be operated at various speeds.

To prevent liquid passing through to the compressor, a capillary tube (6), attached to the outlet pipe of the evaporator (5) and connected to the thermostatic expansion valve (4), controls the amount that the valve opens and closes in relation to the temperature of the low pressure high temperature refrigerant vapour (F4) at the outlet. The atomised refrigerant then passes through the evaporator (5). Fan blown air (A2) passes through the matrix (A3) of the evaporator and is cooled by absorption due to the low temperature refrigerant passing through the evaporator.

A thermostat is positioned in the airflow leaving the evaporator to sense the temperature of the exterior fins. Should ice begin to form, due to a too cold condition, it will signal to disengage the electro-mechanical clutch on the compressor (1).

From the evaporator, low pressure, slightly superheated refrigerant (F5) passes to the compressor to complete the cycle.

AIR CONDITIONING CONTROL SYSTEM

The air conditioning control system comprises relays, thermostat, pressure switches, and a control panel. Together these controls, in conjunction with the cooling fan, compressor clutch and blower, enable minimal input to maintain the required environment inside the vehicle.

Selecting air conditioning provides the added facility of cooled air available to be mixed with warm air from the heater system to give the required interior environmental conditions.

Trinary pressure switch

This switch, located in the high pressure line between the receiver drier and the expansion valve, monitors refrigerant pressure and by means of the relay controls the following system functions:

1. Refrigerant pressure drops below 2.0 bar, 29 lbf/in² (due to possible leakage), the compressor's electro-mechanical clutch is dis-engaged.
2. When pressure rises above 2.0 bar, 29 lbf/in² the compressor's clutch is re-engaged.
3. Refrigerant pressure rises above 32 bar, 455 lbf/in² (due to possible blockage), even with cooling fan operation, the compressor's electro-mechanical clutch is dis-engaged. When the pressure drops below 26 bar, 375 lbf/in² the compressor clutch is re-engaged.

Condenser cooling fan

The condenser cooling fan operates automatically whenever the air conditioning system is switched on.

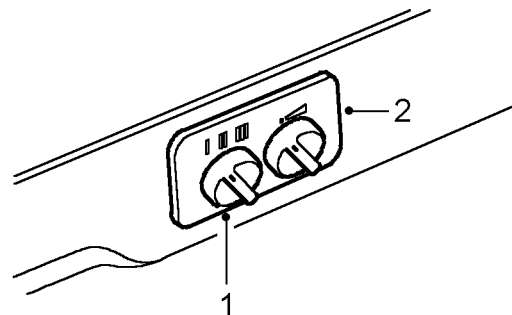

82M0451

1. Blower control

The blower can be operated at various speeds by turning the blower switch to the required position. When the blower is switched off, the air conditioning system will not operate.

2. Temperature control

Rotate the temperature control switch clockwise to increase the cooling effect. Use in conjunction with the blower control as required.



REFRIGERATION SYSTEM FAULTS

For any refrigeration system to function properly all components must be in good working order. The unit cooling cycle and the relationship between air discharge temperature and ambient temperature and the pressures at the compressor can help to determine proper operation of the system.

The length of any cooling cycle is determined by such factors as ambient temperature and humidity, thermostat setting, compressor speed and air leakage into the cooled area, etc. With these factors constant, any sudden increase in the length of the cooling cycle would be indicative of abnormal operation of the air conditioner.

The low and high side pressures at the compressor will vary with changing ambient temperature, humidity, in-car temperature and altitude.

The following items should be checked before operating the system:

1. Compressor drive belt tension.
2. Compressor magnetic clutch operation.
3. Condenser fan operation.
4. Condenser fins, dirt will cause poor cooling and higher operating temperatures.

System check

The following conditions should be checked after operating the system for several minutes:

1. All high pressure lines and components should be hot to the touch.
2. All low pressure lines should be cool to the touch.
3. Inlet and outlet temperatures at the receiver/drier should be at the same temperature (warm). Any very noticeable temperature difference indicates a blocked receiver/drier.
4. Heavy frost on the inlet to the expansion valve may indicate a defective valve or moisture in the system.
5. Evaporation air temperature will vary with ambient temperature and humidity. As humidity increases the outlet temperature will be higher.



GENERAL PRECAUTIONS

The refrigerant used in the air conditioning system is HFC (Hydrofluorocarbon) R134a.



WARNING: R134a is a hazardous liquid and when handled incorrectly can cause serious injury. Suitable protective clothing must be worn when carrying out servicing operations on the air conditioning system.



WARNING: R134a is odourless and colourless. Do not handle or discharge in an enclosed area, or in any area where the vapour or liquid can come in contact with naked flame or hot metal. R134a is not flammable, but can form a highly toxic gas.



WARNING: Do not smoke or weld in areas where R134a is in use. Inhalation of concentrations of the vapour can cause dizziness, disorientation, uncoordination, narcosis, nausea or vomiting.



WARNING: Do not allow fluids other than R134a or compressor lubricant to enter the air conditioning system. Spontaneous combustion may occur.



WARNING: R134a splashed on any part of the body will cause immediate freezing of that area. Also refrigerant cylinders and replenishment trolleys when discharging will freeze skin to them if contact is made.



WARNING: The refrigerant used in an air conditioning system must be reclaimed in accordance with the recommendations given with a Refrigerant Recovery Recycling Recharging Station.



NOTE: Suitable protective clothing comprises: Wrap around safety glasses or helmet, heatproof gloves, rubber apron or waterproof overalls and rubber boots.

REMEDIAL ACTIONS

1. If liquid R134a strikes the eye, do not rub it. Gently run large quantities of eyewash over the eye to raise the temperature. If eyewash is not available cool, clean water may be used. Cover eye with clean pad and seek immediate medical attention.
2. If liquid R134a is splashed on the skin run large quantities of water over the area as soon as possible to raise the temperature. Carry out the same actions if skin comes into contact with discharging cylinders. Wrap affected parts in blankets or similar material and seek immediate medical attention.
3. If suspected of being overcome by inhalation of R134a vapour, seek fresh air. If unconscious, remove to fresh air, apply artificial respiration and/or oxygen and seek immediate medical attention.



NOTE: Due to its low evaporating temperature of -30°C, -22°F R134a should be handled with care.



WARNING: Do not allow a refrigerant container to be heated by a direct flame or to be placed near any heating appliance. A refrigerant container must not be heated above 50°C, 122°F.



WARNING: Do not leave a container of refrigerant without its cap fitted. Do not transport a container of refrigerant that is unrestrained, especially in the boot of a car.

SERVICING PRECAUTIONS

Care must be taken when handling refrigeration system components. Units must not be lifted by their hoses, pipes or capillary lines. Hoses and lines must not be subjected to any twist or stress. Ensure that hoses are positioned in their correct run before fully tightening the couplings, and ensure that all clips and supports are used. Torque wrenches of the correct type must be used when tightening refrigerant connections to the stated value. An additional spanner must be used to hold the union to prevent twisting of the pipe.

Before connecting any hose or pipe ensure that refrigerant oil is applied to the seat of the new 'O' ring but not to the threads.

Check the oil trap for the amount of oil lost.

All protective plugs on components must be left in place until immediately prior to connection.

The receiver/drier contains desiccant which absorbs moisture. It must be positively sealed at all times.



CAUTION: Whenever the refrigerant system is opened, the receiver/drier must be renewed immediately before evacuating and recharging the system.

Use alcohol and a clean cloth to clean dirty connections. Ensure that all new parts fitted are marked for use with **R134a**.

Refrigerant oil

Use the approved refrigerant lubricating oil - Nippon Denso ND-OIL 8.



CAUTION: Do not use any other type of refrigerant oil.

Refrigerant oil easily absorbs water and must not be stored for long periods. Do not pour unused oil back into the container.

When renewing system components, add the following quantities of refrigerant oil:

Condenser	40ml, 1.4 fl oz
Evaporator	80ml, 2.8 fl oz
Pipe or hose	20ml, 0.7 fl oz
Receiver/drier	20ml, 0.7 fl oz
Total refrigerant oil in system =	180ml, 6.3 fl oz

A new compressor is sealed and pressurised with Nitrogen gas. Slowly release the sealing cap, gas pressure should be heard to release as the seal is broken.



NOTE: A new compressor should always have its sealing caps in place and these must not be removed until immediately prior to fitting

Fitting a new compressor

A new compressor is supplied with an oil fill (X) of 180ml, 5.3 fl oz.

A calculated quantity of oil must be drained from a new compressor before fitting.

To calculate the quantity of oil to be drained:

1. Remove sealing plugs from the OLD compressor.
2. Invert compressor and gravity drain oil into measuring cylinder. Rotating the compressor clutch plate will assist complete draining.
3. Note the quantity of oil drained (Y).
4. Calculate the quantity (Q) of oil to be drained from the NEW compressor using the following formula:

$$X - (Y + 20\text{ml}, 0.7 \text{ fl oz}) = Q$$

Rapid refrigerant discharge

When the air conditioning system is involved in accident damage and the circuit is punctured, the refrigerant is discharged rapidly. The rapid discharge of refrigerant will also result in the loss of most of the oil from the system. The compressor must be removed and all the remaining oil in the compressor drained and refilled as follows:

1. Gravity drain all the oil, assist by rotating the clutch plate (not the pulley).
2. Refill the compressor with 130ml, 4.6 fl oz of new refrigerant oil.
3. Plug the inlet and outlet ports.

Servicing Equipment

The following equipment is required for full servicing of the air conditioning system.

Recovery, recycling and charging station

- Leak detector
- Thermometer +20°C to -60°C, 70°F to -70°F
- Safety goggles and gloves



REFRIGERANT RECOVERY, RECYCLING, RECHARGING

Service repair no - 82.30.20/01



WARNING: The air conditioning system is charged with a high pressure, potentially toxic refrigerant. Repairs or servicing must only be carried out by an operator familiar with both the vehicle system and the charging and testing equipment.

All operations must be carried out in a well-ventilated area away from open flame and heat sources.

Always wear safety goggles and gloves when opening refrigerant connections.



WARNING: Wear eye and hand safety protection. Open connections slowly in case liquid or pressure is present. Allow to bleed off slowly.



CAUTION: Overcharging air conditioning system will cause excessive head pressure.

An air conditioning portable Refrigerant Recovery Recycling Recharging Station for use with R134a refrigerant incorporates all the features necessary to recover refrigerant R134a from the air conditioning system, to filter and remove moisture, to evacuate and recharge with the reclaimed refrigerant. The unit can also be used for performance testing and air conditioning system analysis.

The operator must adhere to the equipment manufacturers' instructions.

Recovery and recycling

1. Connect a Refrigerant Station to the high and low pressure servicing connections.
2. Operate the refrigerant recovery system according to the manufacturers instructions.
3. Measure the amount of oil discharged from the system. Add an equal amount of new refrigerant oil to compressor before evacuation sequence.



WARNING: Refrigerant must always be recycled before reuse, to ensure that the purity of the refrigerant is high enough for safe use in the air conditioning system. Recycling should always be carried out with equipment which is design certified by Underwriter Laboratory Inc. for compliance with SAE-J1991. Other equipment may not recycle refrigerant to the required level of purity.

A R134a Refrigerant Recovery Recycling Recharging Station must not be used with any other type of refrigerant.

Refrigerant R134a from domestic and commercial sources must not be used in motor vehicle air conditioning systems.

Evacuation and recharging

1. Add refrigerant oil to compressor if necessary.
2. Renew the receiver/drier.



CAUTION: When a major repair has been carried out, a leak test should be carried out using inert gas.

3. Connect a Refrigerant Station to the high and low pressure servicing connections.



CAUTION: Whenever the refrigerant system is opened, the receiver/drier must be renewed immediately before evacuating and recharging the system.

- Operate the refrigerant evacuation system according to the manufactures instructions.



NOTE: If the vacuum reading is below 700 mm Hg, 28 in Hg after 15 minutes, suspect a leak in the system. Partially recharge the system and check for leaks using an electronic leak tester. Check suction lines first, then run the compressor for 5 minutes and then check the high pressure lines.



CAUTION: The system must be Evacuated immediately before recharging commences. Delay between Evacuation and Recharging is not permitted.

- Operate the refrigerant recharging system according to the manufacturer's instructions.

Refrigerant to charge system = 900 ± 30gm, 32 ± 1 oz.

- If the full charge has not been accepted by the system, start the engine and run it at 1500 rev/min for a minimum of 2 minutes. Switch on the air conditioning system, open the vehicle windows, set the temperature control to cold and switch the blower to maximum speed.
- Consult Refrigerant Station Manual for correct procedure to complete the charge.
- Carry out the air conditioning system performance test.

LEAK TEST SYSTEM

The following instructions refer to an electronic type Refrigerant Leak Detector for use with R134a, which is the safest and most sensitive.



CAUTION: When a major repair has been carried out, a leak test should be carried out using an inert gas (see below).

- Place the vehicle in a well ventilated area but free from draughts, as leakage from the system could be dissipated without detection.
- Follow the instructions issued by the manufacturer of the particular leak detector being used.
- Commence searching for leaks by passing the detector probe around all joints and components, refrigerant gas is heavier than air.
- Insert the probe into an air outlet of the evaporator or into the evaporator drain tube. Switch the air conditioning blower on and off at intervals of ten seconds. Any leaking refrigerant will be gathered in by the blower and detected.
- Insert the probe between the magnetic clutch and compressor to check the shaft seal for leaks.
- Check all service valve connections, valve plate, head and base plate joints and back seal plate.
- Check the condenser for leaks at the pipe unions.
- If any leaks are found, the system must be discharged before rectification.
- Rectify any leaks and recheck for leaks during evacuation prior to charging.

Leak test using inert gas

Use Nitrogen or Helium gas.

- Connect gas line to recharging station.
- Pressurise system to 3 bar, 45 lbf/in².
- Carry out leak test as above.



AIR CONDITIONING SYSTEM - PERFORMANCE TEST



WARNING: R134a is hazardous See Repair, General Precautions .

Carry out this test with bonnet and doors or windows open, air conditioning switched on, temperature control set to cold and blower at maximum speed. Set the air supply control to supply fresh air.

1. Close low pressure valve on refrigerant station.
2. Close high pressure valve on refrigerant station.
3. Connect a Refrigerant Station to the high and low pressure servicing connections.

4. Insert dry bulb thermometer into cold air outlet and position dry and wet bulb thermometer close to outside air inlet.
Do not spill water from the wet thermometer (psychrometer).
5. Start engine and run it at 1500 rev/min for 10 minutes with air conditioning switched on.
6. Read both pressure gauges and thermometers. Check readings against table below with humidity between 60% and 80%.
7. Switch off air conditioning, stop engine, disconnect test equipment.

Performance range

Intake temperature	Outlet temperature	Low pressure	High pressure
68 °F 20 °C	41 - 50°F 5 - 10°C	20 - 23 lbf/in ² 1.4 - 1.6 bar	116 - 190 lbf/in ² 8.0 - 13 bar
75°F 25°C	45 - 60°F 7 - 15°C	21 - 28 lbf/in ² 1.5 - 2.0 bar	130 - 200 lbf/in ² 9.0 - 14 bar
85°F 30°C	46 - 68°F 8 - 20°C	26 - 40 lbf/in ² 1.8 - 2.8 bar	190 - 230 lbf/in ² 13 - 16 bar
95°F 35°C	52 - 72°F 11 - 22°C	36 - 52 lbf/in ² 2.5 - 3.5 bar	230 - 270 lbf/in ² 16 - 19 bar

Table 1

Ambient Temperature		Compound Gauge Readings		High Pressure Gauge Readings	
°C	°F	bar	lbf/in ²	bar	lbf/in ²
16	60	1,3-1,4	15-20	6,9-10,3	100-150
27	80	1,4-1,7	20-25	9,7-13,1	140-190
38	100	1,7-2,1	25-30	12,4-15,5	180-225
43	110	2,1-2,4	30-35	14,8-17,2	215-250

SYSTEM TEST

1. Place the vehicle in a ventilated, shaded area free from excessive draught, with the doors and windows open.
 2. Check that the surface of the condenser is not restricted with dirt, leaves, flies, etc. Do not neglect to check the surface between the condenser and the radiator. Clean as necessary.
 3. Switch on the ignition and the air conditioner air flow control. Check that the blower is operating efficiently at low, medium and high speeds. Switch off the blower and the ignition.
 4. Check that the evaporator condensate drain tube is open and clear.
 5. Check the tension of the compressor driving belt, and adjust if necessary.
 6. Inspect all connections for the presence of refrigerant oil. If oil is evident, check for leaks, and repair as necessary.
-  **NOTE: The compressor oil is soluble in Refrigerant R134a and is deposited when the refrigerant evaporates from a leak.**
7. Start the engine.
 8. Set the temperature controls to cold and switch the air conditioner blower control on and off several times, checking that the magnetic clutch on the compressor engages and releases each time.
 9. With the temperature control at maximum cooling and the blower control at high speed, warm up the engine and fast idle at 1000 rev/min.
 10. Repeat at 1800 rev/min.
 11. Gradually increase the engine speed to the high range and check the sight glass at intervals.
 12. Check for frosting on the service valves.
 13. Check the high pressure hoses and connections by hand for varying temperature. Low temperature indicates a restriction or blockage at that point.
 14. Switch off the air conditioning blower and stop the engine.
 15. If the air conditioning equipment is still not satisfactory, carry out a pressure test as previously described in this section.



COMPRESSOR

Service repair no - 82.10.20

Remove

1. Disconnect battery negative lead.
2. Recover refrigerant from system. **See Adjustment, refrigerant recovery recycling recharging**
3. Remove 2 bolts securing hose flanges to compressor.



WARNING: Wear eye and hand protection when disconnecting components containing refrigerant. Plug all exposed connections immediately.

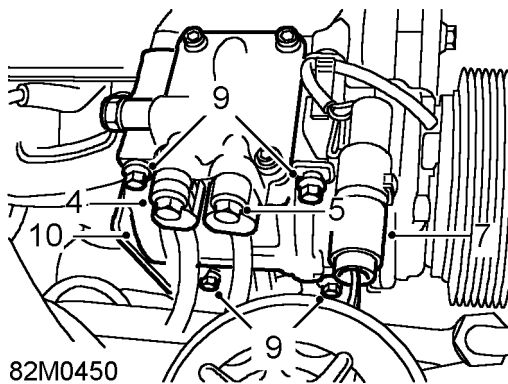

4. Disconnect high pressure pipe from compressor.
5. Disconnect low pressure pipe from compressor.
6. Remove 'O' ring from each flange.
7. Disconnect multiplug from compressor clutch fly-lead
8. Release drive belt from compressor pulley. **See ELECTRICAL, Repair, Auxiliary drive belt**
9. Remove 4 bolts securing compressor to mounting bracket.
10. Remove compressor from mounting bracket.

Refit

11. New compressor: Drain oil from new compressor outlet port. Drain and measure oil equal to amount drained from old compressor, add 30 ml, 1 oz extra to this amount and refill new compressor through outlet port.
12. Locate compressor in mounting bracket, fit bolts and tighten to **25 Nm, 18 lbf ft.**

13. Connect multiplug to fly-lead.
14. Fit NEW 'O' rings to each pipe flange, lubricate with refrigerant oil.
15. Engage pipe flanges, fit bolts and tighten to **10 Nm, 7 lbf ft.**
16. Fit compressor drive belt. **See ELECTRICAL, Repair, Auxiliary drive belt**
17. Recharge refrigerant system. **See Adjustment, refrigerant recovery recycling recharging**
18. Reconnect battery negative lead.
19. Leak test disturbed joints. **See Adjustment, leak test system**
20. Carry out system test. **See Adjustment, System test**

CONDENSER FAN

Service repair no - 82.15.01

Remove

1. Remove grille panel. **See CHASSIS AND BODY, Repair, grille panel**

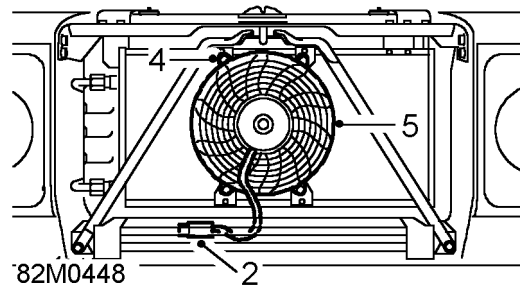

2. Disconnect multiplug from condenser fan fly-lead.
3. Withdraw fly-lead from between radiator and panel.
4. Remove nuts securing fan to condenser brackets.
5. Remove fan assembly.

Refit

6. Position fan on brackets and secure with nuts.
7. Pass fly-lead through and connect to multiplug.
8. Fit grille panel. **See CHASSIS AND BODY, Repair, grille panel**

CONDENSER**Service repair no - 82.15.07****Remove**

1. Disconnect battery negative lead.
2. Recover refrigerant from system. **See Adjustment, refrigerant recovery recycling recharging**
3. Remove condenser fan. **See condenser fan**

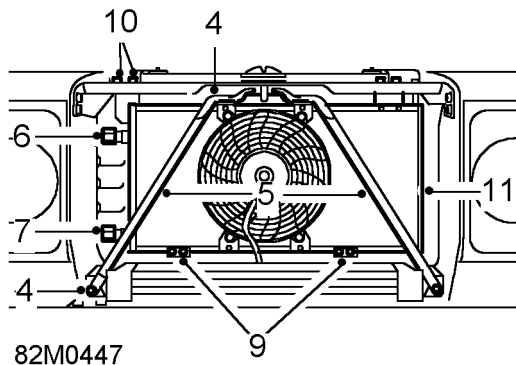

4. Remove 4 bolts securing cross-braces to top panel and chassis brackets.
5. Remove 2 cross-braces.
6. Using a backing spanner, loosen union nut securing inlet pipe to condenser and disconnect.
7. Using a backing spanner, loosen union nut securing outlet pipe to condenser and disconnect.
8. Remove and discard 'O' ring from each union.



CAUTION: Plug the connections.



WARNING: Wear eye and hand protection when disconnecting components containing refrigerant.

9. Remove 4 screws securing lower brackets to condenser.
10. Remove 4 bolts securing brackets to top panel.
11. Release pipes and remove condenser assembly.
Do not carry out further dismantling if component is removed for access only.
12. Transfer brackets to new condenser.

Refit

13. Fit NEW 'O' rings to each union, lubricate with refrigerant oil. New condenser, add 40 ml, 1 fl oz refrigerant oil.
14. Add 40 ml, 1 fl oz of refrigerant oil to new condenser.
15. Position condenser and engage pipes.
16. Secure brackets to top panel.
17. Secure lower brackets to condenser.
18. Using a backing spanner, tighten union nuts securing pipes to condenser.
19. Fit condenser fan. **See condenser fan**
20. Recharge refrigerant system. **See Adjustment, refrigerant recovery recycling recharging**
21. Reconnect battery negative lead.
22. Leak test disturbed joints. **See Adjustment, leak test system**
23. Carry out system test. **See Adjustment, System test**



RECEIVER DRIER

Service repair no - 82.17.01

Remove



CAUTION: If receiver drier is to be refitted, the ports must be blanked off immediately on disconnection. Exposed life of unit is 15 minutes.

1. Disconnect battery negative lead.
2. Recover refrigerant from system. *See Adjustment, refrigerant recovery recycling recharging*



WARNING: Wear eye and hand protection when disconnecting components containing refrigerant.

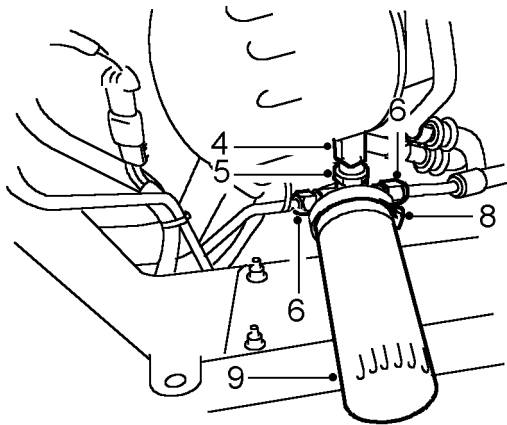

82M0438

3. Clean area around receiver drier connections.
4. Disconnect multiplug from trinary switch.
5. Remove trinary switch from receiver drier.



CAUTION: Plug the connections.

6. Disconnect 2 pipe unions from receiver drier.
7. Remove and discard 'O' rings from pipe flanges.
8. Fully loosen clip securing receiver drier to bracket.
9. Remove receiver drier from clip.

Refit

10. Fit NEW 'O' ring to each pipe flange, lubricate with refrigerant oil.
11. Add 20ml, 0.7 fl oz of refrigerant oil to NEW receiver drier.
12. Position receiver drier in clip, tighten clip but do not clamp.
13. Engage pipes and tighten unions to **6 Nm, 4.5 lbf ft**.
14. Fit trinary switch to receiver drier and tighten to **11Nm, 8 lbf ft**.
15. Connect multiplug to trinary switch.
16. Tighten receiver drier clamp.
17. Evacuate and recharge air conditioning system. *See Adjustment, refrigerant recovery recycling recharging*
18. Perform a leak test on disturbed joints.
19. Carry out system test. *See Adjustment, System test*

TRINARY PRESSURE SWITCH

Service repair no - 82.20.04

Remove

1. Disconnect battery negative lead.
2. Recover refrigerant from system. **See Adjustment, refrigerant recovery, recycling, recharging**

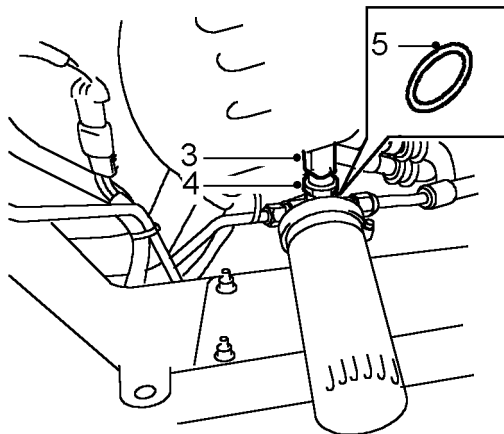

82M0440

3. Access below front RH of vehicle: Disconnect multiplug from switch.
4. Remove switch from adaptor.



WARNING: Wear eye and hand protection when disconnecting components containing refrigerant.

5. Remove 'O' ring from switch and discard.

Refit

6. Lubricate NEW 'O' ring with refrigerant oil and fit to switch.
7. Fit switch to adaptor and tighten to **11 Nm, 8 lbf ft.**
8. Connect multiplug.
9. Evacuate and recharge air conditioning system. **See Adjustment, Refrigerant recovery, recycling, recharging**
10. Reconnect battery negative lead.
11. Carry out system test. **See Adjustment, System test**

RELAY - FAN INTERLOCK

Service repair no - 82.20.08

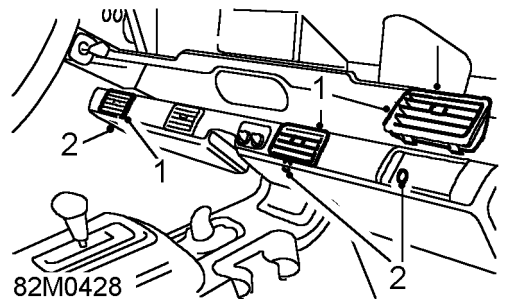
Remove

1. Lever under each bottom corner and extract cold air vents from bezel, 1 from LH side and 2 from RH side.
2. Remove screw securing underside of bezel to panel
3. Remove 3 screws securing inside of bezel to panel

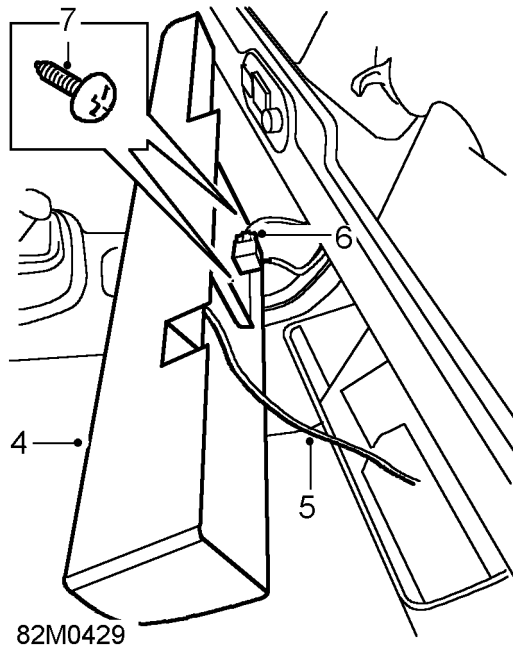

RELAY - CONDENSER FAN

Service repair no - 82.20.09

Remove

1. Disconnect multiplug from relay.



NOTE: Connector wiring: B/S, N/P, N/S, N/W

2. Release securing screw and remove relay from side of evaporator casing.

Refit

3. Fit screw and secure relay to side of casing.
4. Connect multiplug to relay.
5. Carry out system test. **See Adjustment, System test**

4. Lift bezel away from evaporator casing
5. Withdraw capillary tube from evaporator fins.
6. Disconnect multiplug from fan interlock relay.
7. Remove securing screw and remove relay from rear of bezel.

Refit

8. Fit screw and secure relay to rear of bezel.
9. Connect multiplug to fan interlock relay.
10. Position bezel assembly and insert capillary tube 60 mm, 2.5 in into evaporator fins.
11. Fit bezel assembly to panel and above evaporator casing, secure with screws.
12. Fit cold air vents.
13. Carry out system test. **See Adjustment, System test**

CONTROL SWITCHES

Service repair no - 82.20.10 - Temperature Control Switch

Service repair no - 82.20.11 - Fan Switch

Remove

1. Remove fascia duct bezel. *See fascia duct bezel*

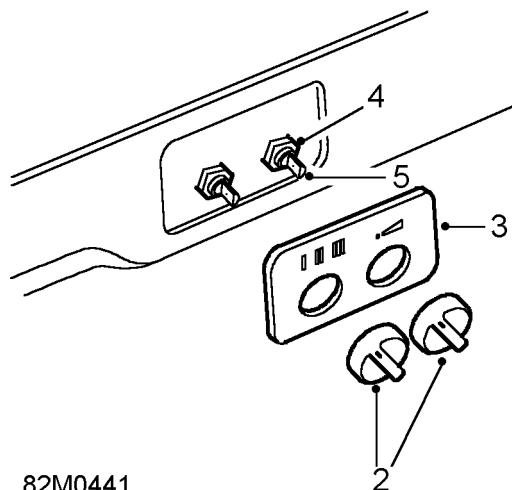

82M0441

2. Pull control knobs from switches.
3. Remove switch panel.
4. Remove nut securing switch to bezel.
5. Remove switch.



NOTE: Fan switch to left.

Refit

6. Fit temperature control switch. Position capillary tube inside duct to RH side.
7. Fit and tighten nut securing switch to bezel.
8. Fit switch panel.
9. Fit control knobs.
10. Fit fascia duct bezel. *See fascia duct bezel; Refit*
11. Carry out system test. *See Adjustment, System test*

RESISTOR UNIT

Service repair no - 82.20.26

Remove

NOTE: Access below evaporator unit.

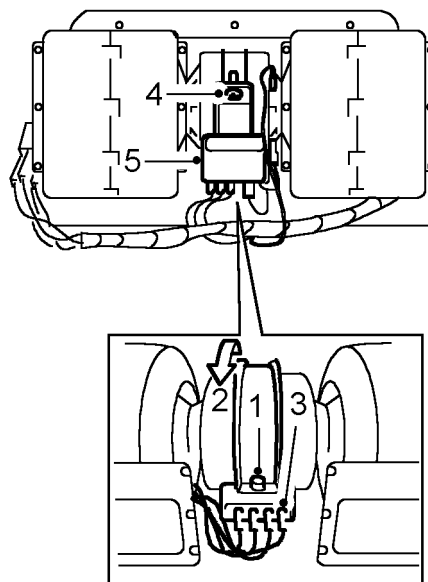

82M0449

1. Loosen outer screw securing resistor unit to clamp.
2. Rotate resistor on motor.
3. Disconnect Lucars from resistor unit.



NOTE: Resistor wires: G, U, R and O

4. Remove screws securing resistor to clamp.
5. Remove resistor unit and clamp.

Refit

6. Position clamp over motor and place resistor, terminals downward, onto motor.
7. Fit screws and tighten inner screw only.
8. Fit Lucars to resistor unit, in correct sequence.
9. Rotate resistor to fitted position and tighten outer screw.
10. Carry out system test. *See Adjustment, System test*



RELAY - EVAPORATOR BLOWER

Service repair no - 82.20.27

Remove

1. Disconnect multiplug from relay.



NOTE: Connector wiring: B, G, N, S/P

2. Release securing screw and remove relay from side of evaporator casing.

Refit

3. Fit screw and secure relay to side of casing.
4. Connect multiplug to relay.
5. Carry out system test. **See Adjustment, System test**

RELAY - COMPRESSOR

Service repair no - 82.20.51

Remove

1. Disconnect multiplug from relay.



NOTE: Connector wiring: G, B/W, N/R, N/W

2. Release securing screw and remove relay from side of evaporator casing.

Refit

3. Fit screw and securing relay to side of casing.
4. Connect multiplug to relay.
5. Carry out system test. **See Adjustment, System test**

FASCIA DUCT BEZEL

Service repair no - 82.20.79

Remove

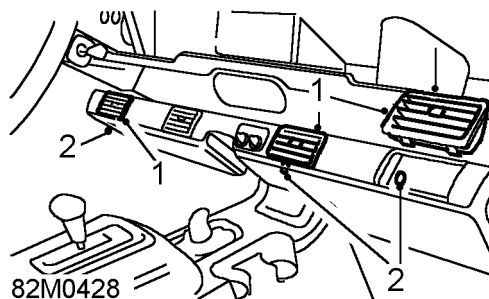

1. Lever under each bottom corner and remove cold air vents from bezel.
2. Remove screw securing underside of bezel to panel.
3. Remove 3 screws securing inside of bezel to panel.

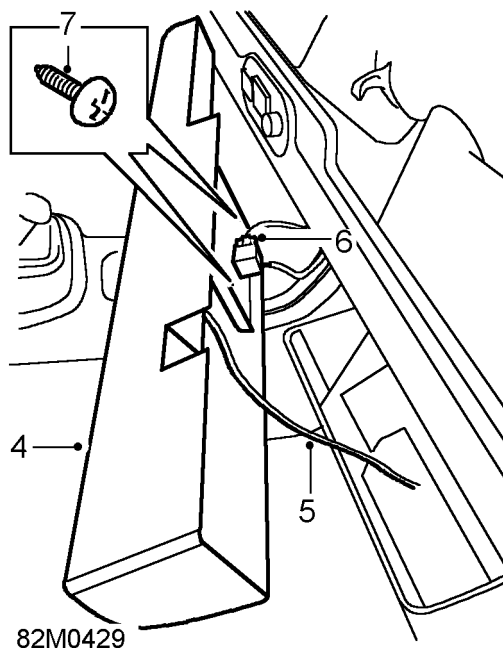

4. Lift bezel away from evaporator casing.
5. Withdraw capillary tube from evaporator fins.
6. Disconnect multiplug from fan interlock relay.
7. Remove 2 screws securing cover to rear of bezel.

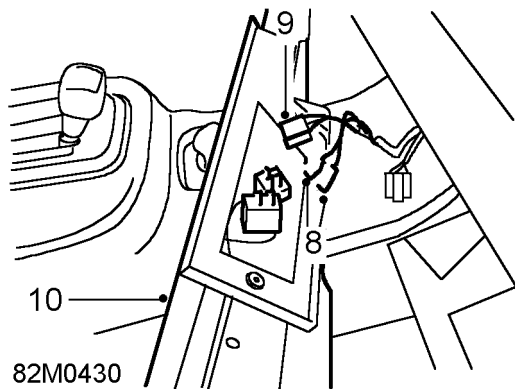

8. Disconnect 2 Lucars from temperature control switch.
9. Disconnect multiplug from fan switch.
10. Remove bezel assembly.

Do not carry out further dismantling if component is removed for access only.

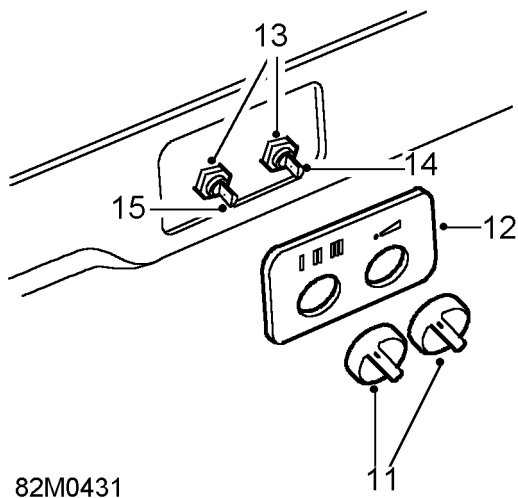

11. Pull control knobs from switches.
12. Remove switch panel.
13. Remove nuts securing switches to bezel.
14. Remove temperature control switch.
15. Remove fan switch.
16. Transfer components to new panel.

Refit

17. Position bezel assembly and connect multiplug to fan switch.
18. Connect Lucars to temperature control switch.
19. Position capillary tube to RH side of bezel.
20. Fit screws securing cover to rear of bezel.
21. Connect multiplug to fan interlock relay.
22. Position bezel assembly and insert capillary tube 60 mm, 2.5 in into evaporator fins
23. Fit bezel assembly to panel and above evaporator casing, secure with screws.
24. Fit cold air vents.
25. Carry out system test. **See Adjustment, System test**



EXPANSION VALVE

Service repair no - 82.25.01

Remove

1. Remove evaporator. **See evaporator**
2. Using a backing spanner, loosen union nut and remove high pressure pipe.
3. Discard 'O' ring.
4. Pull insulation away from capillary tube coil and low pressure pipe.
5. Loosen clip and withdraw capillary tube coil from low pressure pipe.
6. Loosen capillary tube union and disconnect union from low pressure pipe. Discard 'O' ring.
7. Using a backing spanner, loosen union nut and remove expansion valve from pipe. Discard 'O' ring.

Refit

8. Lubricate NEW 'O' rings with refrigerant oil and fit to pipe ends.
9. Fit expansion valve to pipe, DO NOT tighten union nut.
10. Connect capillary tube and tighten union nut.
11. Position capillary tube coil on low pressure pipe and secure with clip.
12. Wrap capillary coil and union with 'Prestite' tape.
13. Connect high pressure pipe to expansion valve, carefully align with low pressure pipe and tighten union nut.
14. Tighten expansion valve union nut.
15. Fit evaporator. **See evaporator; Refit**
16. Carry out system test. **See Adjustment, System test**

BLOWER MOTOR ASSEMBLY

Service repair no - 82.25.14

Remove

1. Remove evaporator. **See evaporator**
2. Move passenger seat fully rearward.
3. Position evaporator unit above centre console and seat panel.

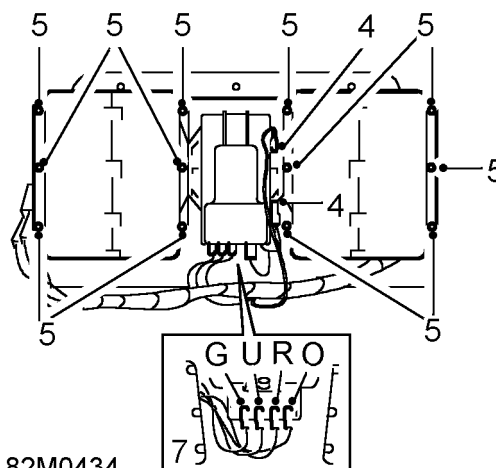

4. Disconnect Lucars (B and O wires) from blower motor.
5. Remove screws securing blower units to casing.
6. Release blower unit flanges from casing, sealed with sealant.
7. Disconnect Lucars from resistor unit.



NOTE: Wire positions: G, U and R wires.

8. Remove blower motor unit.

Do not carry out further dismantling if component is removed for access only.

9. Remove screws securing resistor unit to blower motor. Note alignment of resistor unit.
10. Remove resistor unit and bracket.
11. Fit resistor unit to blower motor.

Refit

12. Clean sealant from blower flanges.
13. Apply a bead of Silicone Sealant around each blower flange.
14. Connect Lucars to resistor unit in correct order.
15. Position blower flanges on evaporator casing and secure with screws.
16. Connect Lucars (B and O wires) to blower motor.
17. Fit evaporator. **See evaporator**
18. Carry out system test. **See Adjustment, System test**

EVAPORATOR

Service repair no - 82.25.20

Remove

1. Disconnect battery negative lead.
2. Recovery refrigerant from air conditioning system. **See Adjustment, Refrigerant recovery recycling recharging**
3. Remove fascia duct bezel. **See fascia duct bezel**

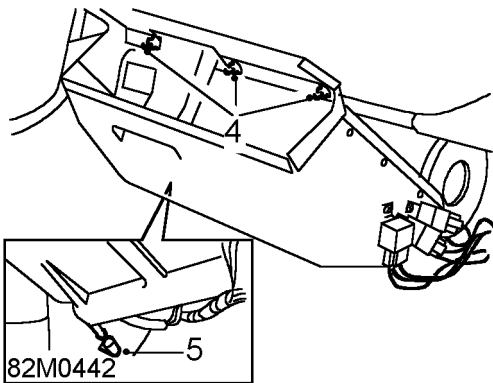

4. Remove 3 nuts securing evaporator casing to mounting bracket.
5. Disconnect drain tube from drain pipe on LH side of casing.
6. Position 2 heater hoses to side of air intake tube.



WARNING: Wear eye and hand protection when disconnecting components containing refrigerant.

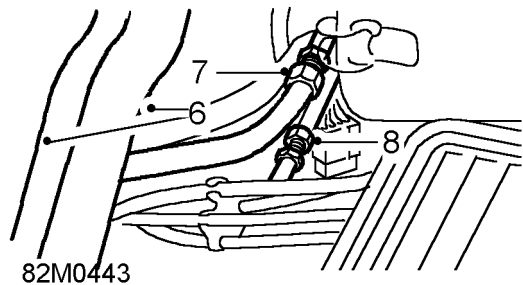

7. Using a backing spanner, loosen union nut from evaporator return pipe and disconnect. Discard 'O' ring.
8. Using a backing spanner, loosen union nut from evaporator feed pipe and disconnect. Discard 'O' ring.



CAUTION: Plug the connections.

9. Ease 2 evaporator studs from their rubber bushes, release grommet from bulkhead, withdraw pipes from aperture and position evaporator unit on floor.

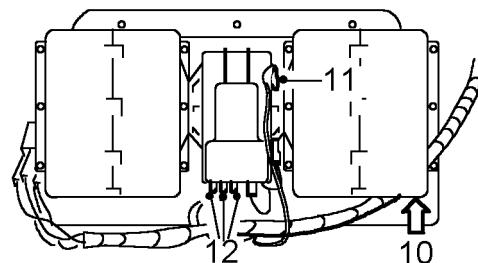

82M0444

10. Remove screw securing harness 'P' clip to rear of casing.
11. Disconnect Lucar (B wire) from motor.
12. Disconnect Lucars (G, U, and R wires) from resistor unit.

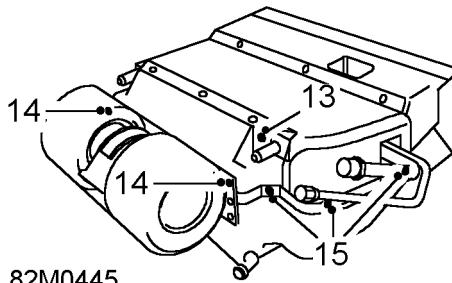

82M0445

13. Remove screw securing mounting bracket flange to casing.
14. Remove screws securing each end of blower flanges to upper casing.
15. Remove 6 screws securing upper to lower casing.

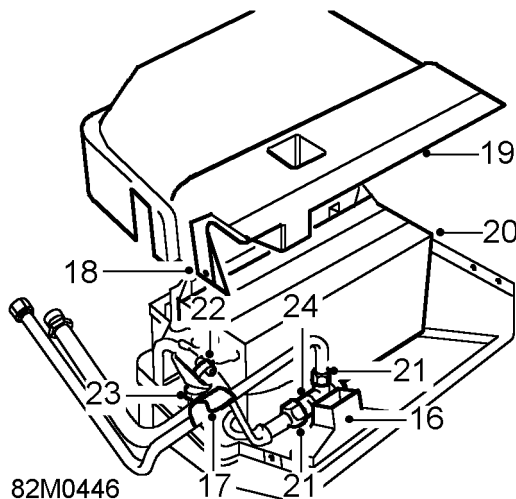

82M0446

16. Remove tape sealing air duct inside casing.
17. Release tape sealing pipes to casing.
18. Cut through sealant along casing joint and gaskets.
19. Ease upper from lower casing and remove upper casing.
20. Lift evaporator unit from lower casing. **Do not carry out further dismantling if component is removed for access only.**
21. Using a backing spanner, loosen union nut from pipe and remove high pressure pipe. Discard 'O' ring.
22. Loosen clip and withdraw capillary tube coil from low pressure pipe and withdraw coil from pipe.
23. Loosen capillary tube union nut and disconnect from low pressure pipe. Discard 'O' ring.

24. Using a backing spanner, loosen union nut and remove expansion valve from pipe. Discard 'O' ring.

Refit

25. Lubricate NEW 'O' rings with refrigerant oil and fit to pipe ends.
26. Fit expansion valve to pipe, DO NOT tighten union nut.
27. Connect capillary tube and tighten union nut.
28. Position capillary tube coil on low pressure pipe and secure with clip.
29. Wrap capillary coil and union with prestite tape.
30. Connect high pressure pipe to expansion valve, carefully align with low pressure pipe and tighten union nut.
31. Tighten expansion valve union nut.
32. Position evaporator unit in lower casing, align bracket and engage blower flange screws, DO NOT tighten.
33. Position upper casing, engage lower casing flange and secure with screws. Ensure mounting bracket screw engages evaporator bracket.
34. Tighten blower flange screws.
35. Apply Silicone sealant to casing joint and insulating tape to seal pipes to casing.
36. Apply sealing tape around air duct joint.
37. Position evaporator unit in footwell.
38. Connect multiplugs to compressor relays and secure harness 'P' clip.
39. Connect Lucars (G, U, and R) to resistor unit and (B) to motor.
40. Lift evaporator, insert pipes into aperture and engage mounting studs.
41. Connect drain tube to pipe.
42. Fit grommet into aperture.
43. Lubricate NEW 'O' rings with refrigerant oil and fit to
44. Carry out a functional check. joints.
45. Using a backing spanner, engage high pressure pipe and tighten union nut.
46. Using a backing spanner, engage low pressure pipe and tighten union nut.
47. Fit nuts and secure evaporator casing to mounting bracket.
48. Fit fascia duct bezel. **See fascia duct bezel**
49. Evacuate and recharge air conditioning system. **See Adjustment, refrigerant recovery recycling recharging**
50. Reconnect battery negative lead.
51. Perform leak test on disturbed joints
52. Carry out system test. **See Adjustment, System test**

WIRING HARNESS - SUPPLEMENTARY

Service repair no - 86.70.23

Remove

1. Remove evaporator. *See evaporator*

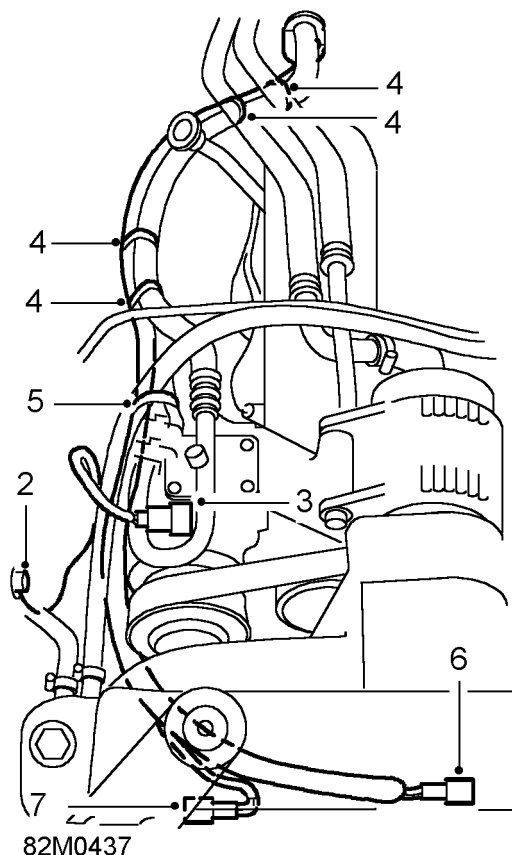

2. Remove nut and release earth eyelet from fender.
3. Disconnect multiplug from compressor fly-lead.
4. Remove 4 ties securing harness to air conditioning hoses.
5. Remove tie securing harness to engine harness.
6. Above chassis front crossmember, disconnect multiplug from condenser fan fly-lead.
7. Disconnect multiplug from trinary switch.
8. Release ties securing harness to pipes.

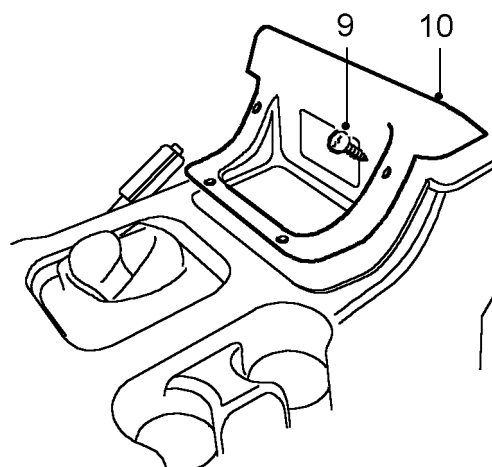

82M0435

9. Remove 4 screws securing fusebox cover to centre console.
10. Remove cover.

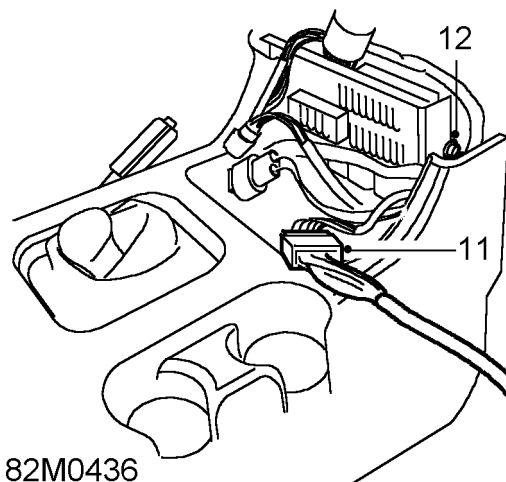

82M0436

11. Disconnect multiplug from main harness.
12. Remove screw securing earth eyelet to fusebox bracket.
13. Pull harness from between centre console and bulkhead.
14. Remove grommet from harness.
15. Remove 'P' clip from harness.
16. Extract harness from front of engine compartment and pass through bulkhead into footwell area. Remove air conditioning harness.

**Refit**

17. Position harness in footwell and route harness into engine bay, follow evaporator and receiver drier hoses to receiver drier.
18. Fit grommet and 'P' clip to harness.
19. Position harness between centre console and bulkhead with multiplugs in fusebox area.
20. Secure earth eyelet to fusebox bracket.
21. Connect multiplugs to main harness.
22. Position switch harness to RH side of console, fit fusebox cover and secure with screws.
23. Connect multiplug to trinary switch and condenser fan fly-lead.
24. Secure earth eyelet to fender.
25. Connect multiplug to compressor fly-lead.
26. Secure harness to air conditioning hoses with ties.
27. Secure harness to engine harness with tie.
28. Fit evaporator. **See evaporator**
29. Perform leak test on disturbed joints
30. Carry out system test. **See Adjustment, System test**



TORQUE VALUES

Air conditioning	Nm	lbf ft
Compressor to mounting bracket	25	18
Compressor pipe flange bolts	10	7
Receiver drier union bolts	6	4.5
Trinary pressure switch	11	8
Pressure pipe union nuts - M16	14	10
Discharge pipe union nuts - M22	22	16
Suction pipe union nuts - M24	33	24



WINDSCREEN WIPER MOTOR AND DRIVE RACK

Service repair no - 84.15.09

Service repair no - 84.15.12 - Wiper Motor

Remove

1. Disconnect battery.
2. Remove wiper arms. *See Windscreen wiper arms*
3. Remove fascia duct bezel. *See AIR CONDITIONING, Repair, Fascia duct bezel*
4. Remove screw securing door check strap cover.
5. Remove door check strap cover.

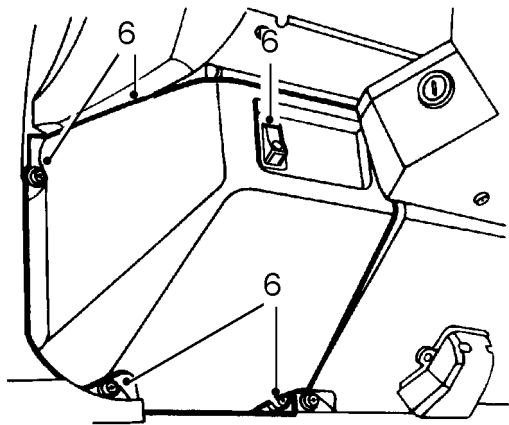

84M0269

6. Remove 3 screws and withdraw wiper motor cover. Disconnect instrument illumination switch multi-plug.
7. Disconnect multi-plug from wiper motor.
8. Disconnect wiper motor earth lead. (Not applicable on 97 MY vehicles).
9. Lift rubber sleeve and slacken wiper motor to drive tube nut.
10. Remove 2 screws and release wiper motor retaining strap.
11. Fully unscrew tube nut.
12. Pull wiper motor and drive rack clear of tube and retrieve mounting pad and earth tag.

Do not carry out further dismantling if component is removed for access only.

13. Remove 4 screws and lift off gearbox cover.
14. Remove circlip and small plain washer securing connecting rod.
15. Remove connecting rod and disconnect drive rack.

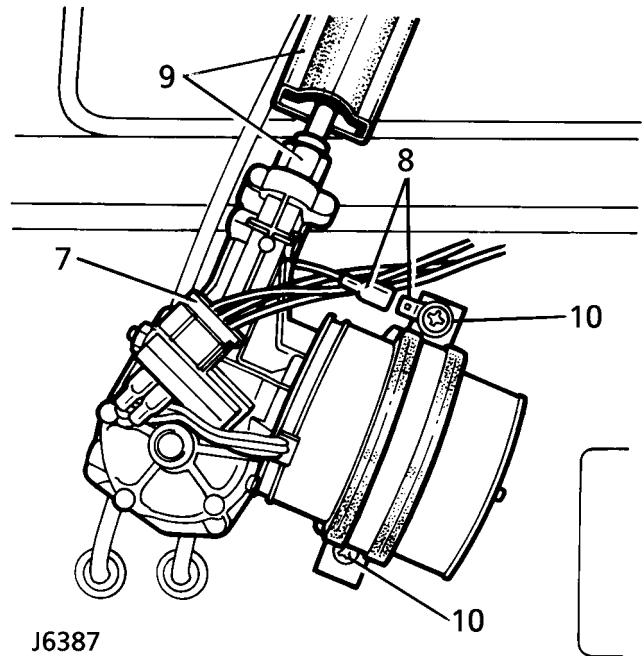

J6387

Refit



NOTE: Use Ragosine Listate Grease to lubricate gear wheel teeth, connecting rod pin and cable rack.

16. Ensure large flat washer is in place over crankpin.
17. Connect drive rack to pin and fit connecting rod over crankpin and secure with small plain washer and circlip.
18. Fit gear wheel and secure with screws.
19. Feed wiper motor drive rack into tube until fully seated.
20. Loosely fit drive tube securing nut.
21. Fit wiper motor securing strap and mounting pad. Align motor and tighten fixing screws.
22. Fully tighten tube nut and fit rubber sleeve.
23. Reconnect earth lead and multi-plug.
24. Fit wiper blades. *See Windscreen wiper arms*
25. Reconnect battery and test operation of wiper motor and drive assembly. If necessary, adjust position of wiper blades.
26. Fit instrument illumination switch multi-plug.
27. Fit cover and door check strap cover.
28. Refit fascia duct bezel. *See AIR CONDITIONING, Repair, Fascia duct bezel*

WINDSCREEN WIPER ARMS

Service repair no - 84.15.01

Remove

1. Pull wiper arm away from windscreen.
2. Using a small screwdriver, hold back spring clip which retains arm to spindle adaptor.
3. Pull wiper arm from splined adaptor.

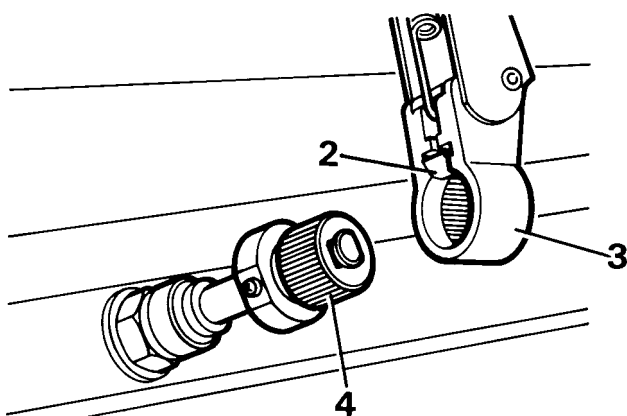

ST3340M

Refit

4. Switch wiper motor to 'park' position, with grub screw retaining adaptor, uppermost.
5. Push arm on to adaptor ensuring that wiper blade is just clear of windscreen surround rubber.
6. Operate wipers and, if necessary, adjust position of arms.

WINDSCREEN WIPER/WASHER SWITCH

Service repair no - 84.15.34

For remove and refit procedure *See ELECTRICAL, Repair, Windscreen wiper/washer switch*

REAR SCREEN WIPER AND WASHER SWITCHES

Service repair no - 84.30.27 - Rear Screen Washer Switch

Service repair no - 84.35.33 - Rear Screen Wiper Switch

For remove and refit procedure *See ELECTRICAL, Repair, Heated rear screen, rear wiper and washer switches*



WINDSCREEN WIPER WHEEL BOXES

Service repair no - 84.15.25

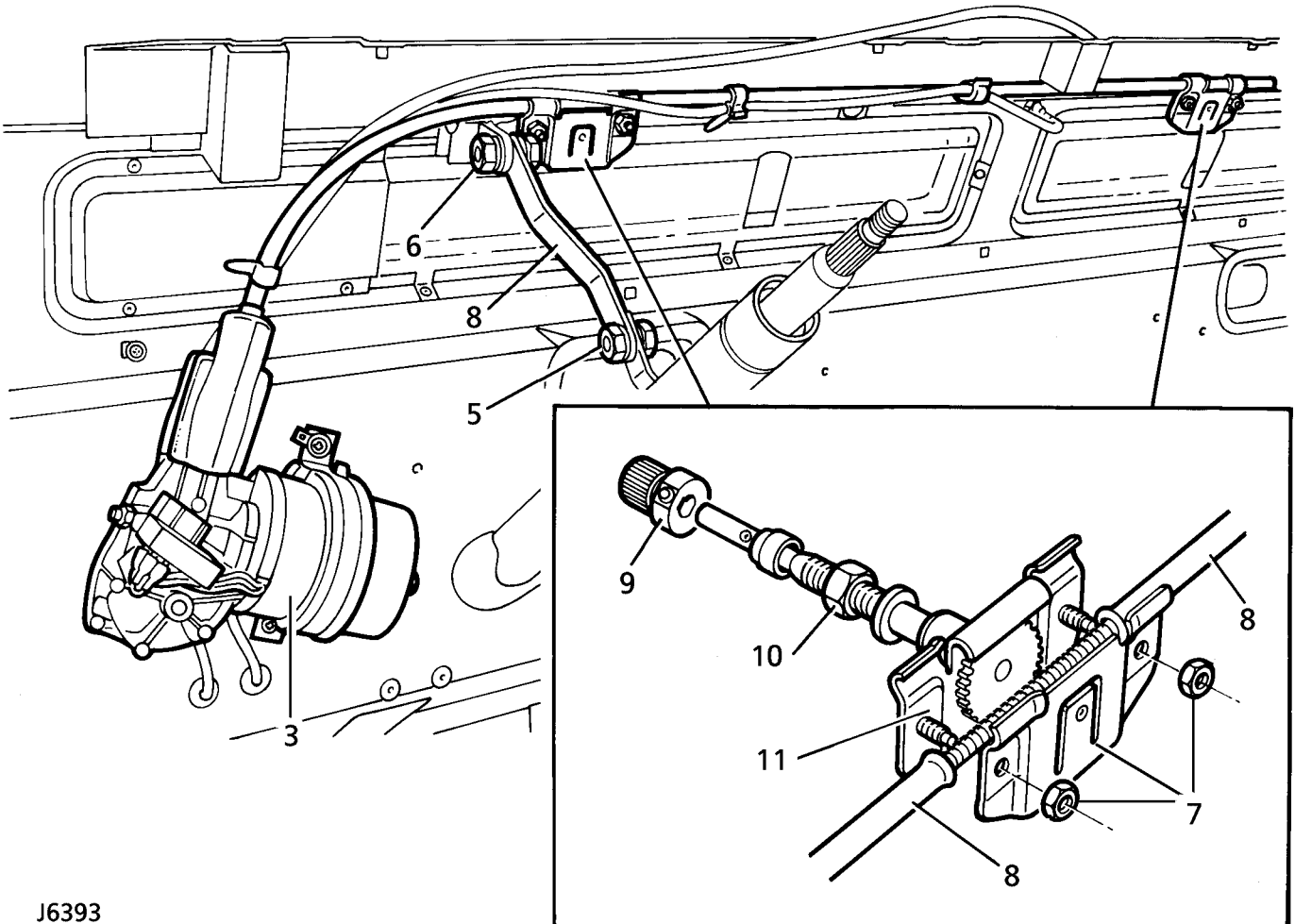

J6393

Remove

1. Disconnect battery.
2. Remove wiper arms. *See Windscreen wiper arms*
3. Remove wiper motor and drive rack. *See Wiper motor and drive rack*
4. Remove instrument housing, fascia crash pad, and ventilator grille panel.
5. Slacken steering column support rod lower fixing.
6. Remove steering column upper support fixing.
7. Slacken nuts to release back plates from LH and RH wheel boxes.
8. Remove drive rack tubes.
9. Slacken grub screws and remove wiper arm adaptors.
10. Remove LH and RH wheelbox spindle nuts.
11. Remove wheel box assemblies from vehicle.

Refit



NOTE: During reassembly, all fixings related to wiper motor and wheelboxes are finger tightened only, until all components are correctly aligned.

12. Fit wheelboxes to bulkhead and secure with retaining nuts and washers.
13. Fit drive rack tubes to wheelboxes.
14. Apply grease to drive rack and wheelboxes.
15. Align wiper motor and mounting pad, secure with retaining strap and tighten drive tube nut.
16. Fully tighten wheelbox back plate nuts.
17. Fully tighten both wheelbox spindle nuts.
18. Fit wiper arm adaptors and secure with grub screw.
19. Before refitting panels fit wiper blades, connect multi-plug and ground lead, reconnect battery and check wiper operation.
20. If satisfactory, secure steering column upper and lower fixings and tighten to correct torque.
21. Fit ventilator grille panel, fascia crash pad, instrument housing and all other components removed to gain access to wiper motor and wheelboxes.

REAR WIPER MOTOR

Service repair no - 84.35.12

Remove

1. With assistance, unscrew 3 retaining nuts and remove spare wheel from rear door mounting studs.

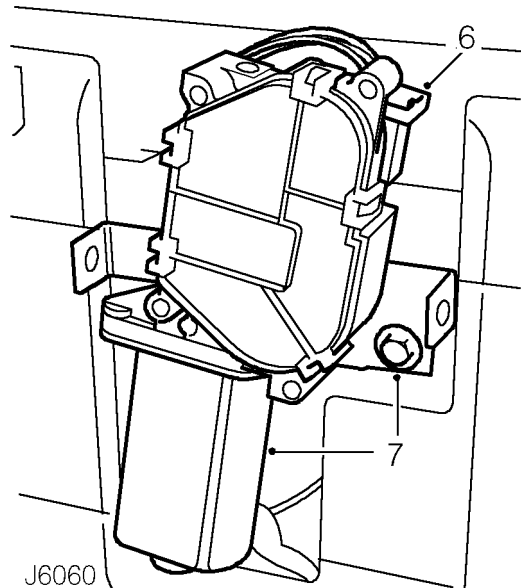
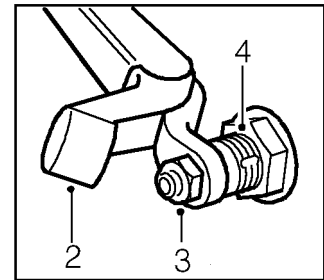

2. Lift wiper arm end cap to gain access to securing nut.
3. Remove nut and withdraw wiper arm from drive spindle.
4. Remove retaining nut, plain washer and rubber washer securing wiper motor drive spindle to door.
5. Remove 2 screws and remove cover from wiper motor mounting bracket.
6. Disconnect wiper motor harness multi-plug.
7. Remove bolt, with rubber washer, and remove wiper motor from rear door.

**Refit**

8. Locate wiper motor drive spindle through aperture in rear door.
9. Position wiper motor mounting bracket and secure to rear door. Tighten bolt to **23 Nm, 17 lbf/ft.**
10. Reconnect harness multi-plug.
11. Secure drive spindle to door.
12. Fit wiper motor cover.
13. Align wiper arm to bottom of heater element and push arm onto spindle, tighten nut and fit end cap.
14. Fit spare wheel. Tighten retaining nuts to **130Nm, 95 lbf/ft.**



WIPER MOTOR

Service repair no - 84.15.18.

Dismantle

1. Remove wiper motor from vehicle. *See Repair, Wiper motor and drive rack*
2. Remove wiper motor gearbox cover.
3. Remove circlip and plain washer securing connecting rod.
4. Withdraw connecting rod.
5. Withdraw flat washer.
6. Remove circlip and washer securing shaft and gear.
7. Clean any burrs from gear shaft and withdraw gear.
8. Withdraw dished washer.
9. Add alignment marks to yoke and gearbox for reassembly.
10. Remove yoke securing bolts.

11. Withdraw yoke and armature.
12. Remove brush gear assembly.
13. Remove limit switch.

Inspection and test

14. Check brushes for excessive wear, if they are worn to 4,8 mm in, 0.21 in length, fit a new brush gear assembly.
15. Using a push type gauge, check that brush spring pressure is 140 to 200 g, 5 to 7 oz when bottom of brush is level with bottom of slot in brush box. Fit a new brush gear assembly if springs are not satisfactory.
16. Test armature for insulation and open- or short-circuits. Use a 110 V 15 W test lamp. Fit a new armature if faulty.
17. Examine gear wheel for damage or excessive wear.

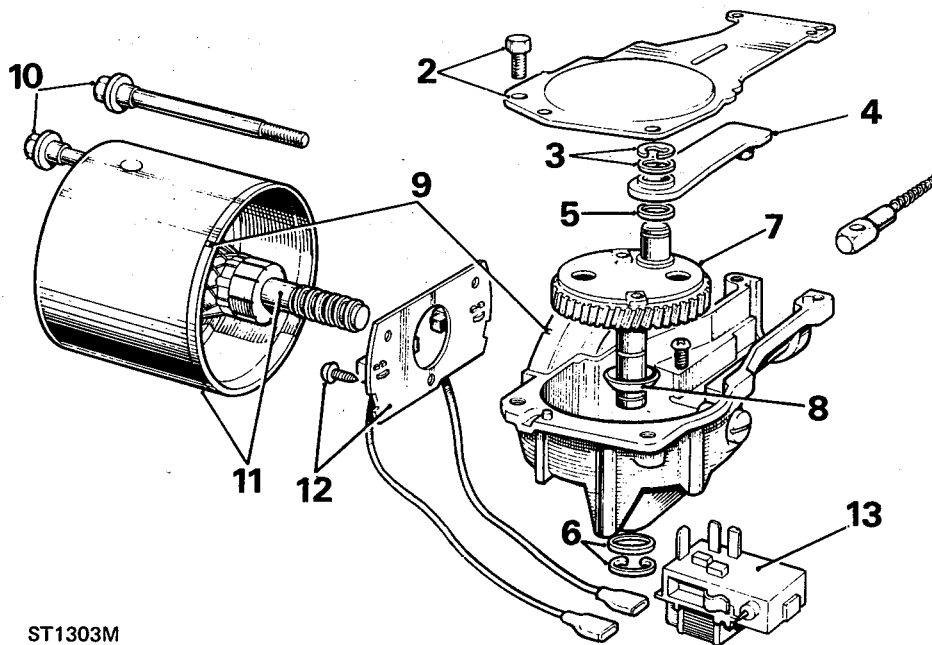

ST1303M

Key to wiper motor components

- | | |
|--|-----------------------------------|
| 1. Flexible drive | 8. Dished washer |
| 2. Gearbox cover | 9. Alignment marks - yoke to body |
| 3. Connecting-rod retaining washer and circlip | 10. Yoke securing bolts |
| 4. Connecting-rod | 11. Armature and yoke |
| 5. Flat washer | 12. Brush gear assembly |
| 6. Gear shaft retaining washer and circlip | 13. Limit switch |
| 7. Drive gear | |

Assemble

Use Ragosine Listate Grease to lubricate gear wheel teeth, armature shaft worm gear, connecting rod and pin, cable rack and wheelbox gear wheels.

Use Shell Turbo 41 oil sparingly to lubricate bearing bushes, armature shaft bearing journals, gear wheel shaft and wheelbox spindles. Thoroughly soak felt washer in yoke bearing with oil.

18. Fit limit switch.
19. Fit brush gear assembly.

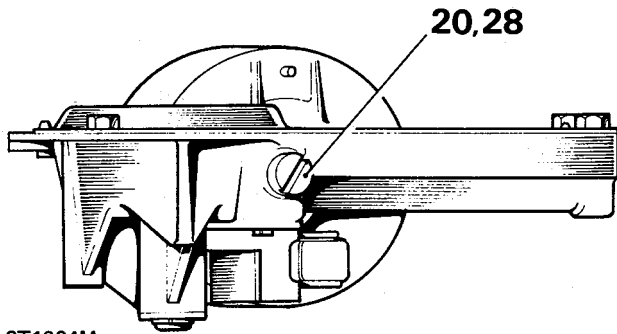

ST1304M

20. Fit armature and yoke to gearbox using alignment marks, secure with yoke retaining bolts tightening to **23 Nm, 17 lbf/ft.** If a replacement armature is being fitted slacken thrust screw to provide end-float for fitting yoke.
21. Fit dished washer beneath gear wheel with concave side towards gear wheel.
22. Fit gear wheel to gearbox.
23. Secure gear wheel shaft with plain washer and circlip.
24. Fit larger flat washer over crankpin.
25. Fit connecting rod and secure with smaller plain washer and circlip.
26. Fit gearbox cover and secure with retaining screws.
27. Connect electrical leads between wiper motor and limit switch.
28. To adjust armature shaft end-float, hold yoke vertically with adjuster screw uppermost. Carefully screw in adjuster until resistance is felt, then back-off one quarter turn.



TORQUE VALUES

	Nm	lbf ft
Wiper motor to yoke bolts	23	17
Rear wiper motor mounting bracket bolts	23	17
Spare wheel	130	95



ELECTRICAL EQUIPMENT

Description

The electrical system is Negative ground, and it is most important to ensure correct polarity of the electrical connections at all times. Any incorrect connections made when reconnecting cables may cause irreparable damage to the semi-conductor devices used in the generator and regulator. Incorrect polarity would also seriously damage any transistorized equipment such as a radio.



WARNING: During battery removal or before carrying out any repairs or maintenance to electrical components always disconnect the battery negative '-' lead first. If the positive '+' lead is disconnected with the negative '-' lead in place, accidental contact of the wrench to any grounded metal part could cause a severe spark, possibly resulting in personal injury. Upon installation of the battery the positive '+' lead must be connected first.

GENERATOR

The generator is a 3 phase, field sensed unit. The rotor and stator windings produce three phase alternating current, AC, which is rectified to direct current, DC. The electronic voltage regulator unit controls the generator output voltage by high frequency switching of the rotor field circuit. Use only the correct auxiliary drivebelt. Occasionally check that the engine and generator pulleys are accurately aligned.

It is essential that good electrical connections are maintained at all times. Of particular importance are those in the charging circuit (including those at the battery) which should be occasionally inspected to see that they are clean and tight. In this way any significant increase in circuit resistance can be prevented.

Do not disconnect battery cables while the engine is running or damage to the semi-conductor devices may occur. It is also inadvisable to break or make any connections in the generator charging and control circuits while the engine is running.

The electronic voltage regulator employs micro-circuit techniques resulting in improved performance under difficult service conditions. The whole assembly is encapsulated in silicone rubber and housed in an aluminium heat sink, ensuring complete protection against the adverse effects of temperature, dust, and moisture etc.

The regulating voltage is set during manufacture to give the required regulating voltage range of 14.2 ± 0.2 volts, and no adjustment is necessary. The only maintenance needed is the occasional check on terminal connections and wiping with a clean dry cloth.

The generator system provides for direct connection of a charge (ignition) indicator warning light, and eliminates the need for a field switching relay or warning light control unit. The lamp should be checked regularly. In the event of bulb failure, an 'exciter' voltage is supplied through a resistor, wired in parallel to the bulb, ensuring that generator output is maintained.

When using rapid charge equipment to re-charge the battery, the battery **MUST** be disconnected from the vehicle.



ELECTRICAL PRECAUTIONS

The following [fender]guidelines are intended to ensure the safety of the operator whilst preventing damage to electrical and electronic components fitted to the vehicle.

Polarity

Never reverse connect the vehicle battery and always observe the correct polarity when connecting test equipment.

High voltage circuits

 **WARNING: Before commencing work on an ignition system, all high tension terminals, adaptors and diagnostic equipment for testing should be inspected to ensure that they are adequately insulated and shielded to prevent accidental personal contacts and minimize the risk of shock. Wearers of surgically implanted pacemaker devices should not be in close proximity to ignition circuits or diagnostic equipment.**

Whenever disconnecting live high tension circuits always use insulated pliers and never allow the open end of a high tension lead to come into contact with other components particularly electronic control units. Exercise caution when measuring the voltage on the coil terminals while the engine is running, since, high voltage spikes can occur on these terminals.

Connectors and harness

Always ensure that these items are dry and oil free before disconnecting and connecting test equipment. Never force connectors apart either by using tools or by pulling on the wiring harness. Always ensure locking tabs are disengaged before removal and note orientation to enable correct reconnection. Ensure that any protective covers and substances are replaced if disturbed. Having confirmed a component to be faulty switch-off the ignition and disconnect the battery. Remove the component and support the disconnected harness. When replacing the component keep oily hands away from electrical connection areas and push connectors home until any locking tabs fully engage.

Battery disconnecting

Before disconnecting the battery, switch off all electrical equipment.

Battery charging

Recharge the battery out of the vehicle and keep the top well ventilated. While being charged or discharged, and for approximately 15 minutes afterwards, batteries emit hydrogen gas which is flammable. Always ensure any battery charging area is well ventilated and that every precaution is taken to avoid naked flames and sparks.

GENERAL PRECAUTIONS

Switch-off ignition prior to making any connection or disconnection in the system as electrical surge caused by disconnecting 'live' connections can damage electronic components. Ensure hands and work surfaces are clean and free of grease, swarf, etc. as grease collects dirt which can cause tracking or high-resistance contacts. When handling printed circuit boards, treat them as you would a disc - hold by the edges only. Prior to commencing a test, and periodically during a test, touch a good earth, for instance, a cigar lighter socket, to discharge body static as some electronic components are vulnerable to static electricity.

BATTERY

Service repair no - 86.15.01

Remove

WARNING: During battery removal or before carrying out any repairs or maintenance to electrical components always disconnect negative '-' lead first. If positive '+' lead is disconnected with negative '-' lead in place, accidental contact of a wrench to any grounded metal part could cause a severe spark, possibly resulting in personal injury. Upon installation of battery always connect positive '+' lead first.

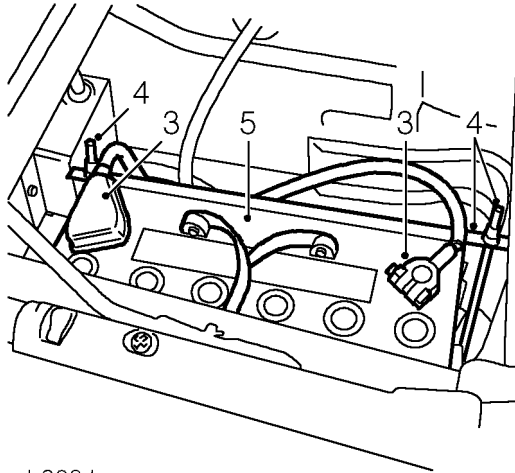

J 6081

1. Remove LH front seat cushion.
2. Release clip and remove battery access cover.
3. Disconnect both battery leads, negative '-' first.
4. Slacken securing nuts and move battery clamp, with 'J' bolts aside.
5. Remove battery.

Refit

6. Clean off corrosion and neutralize. Coat battery clamps and terminals with petroleum jelly.
7. Position battery and secure with clamp. Ensure 'J' bolts are hooked correctly under retaining brackets on base of battery box.
8. Reconnect battery leads, positive '+' lead first.
9. Fit battery access cover and secure with clip.
10. Fit seat cushion.



HEADLAMP

Service repair no - 86.40.02

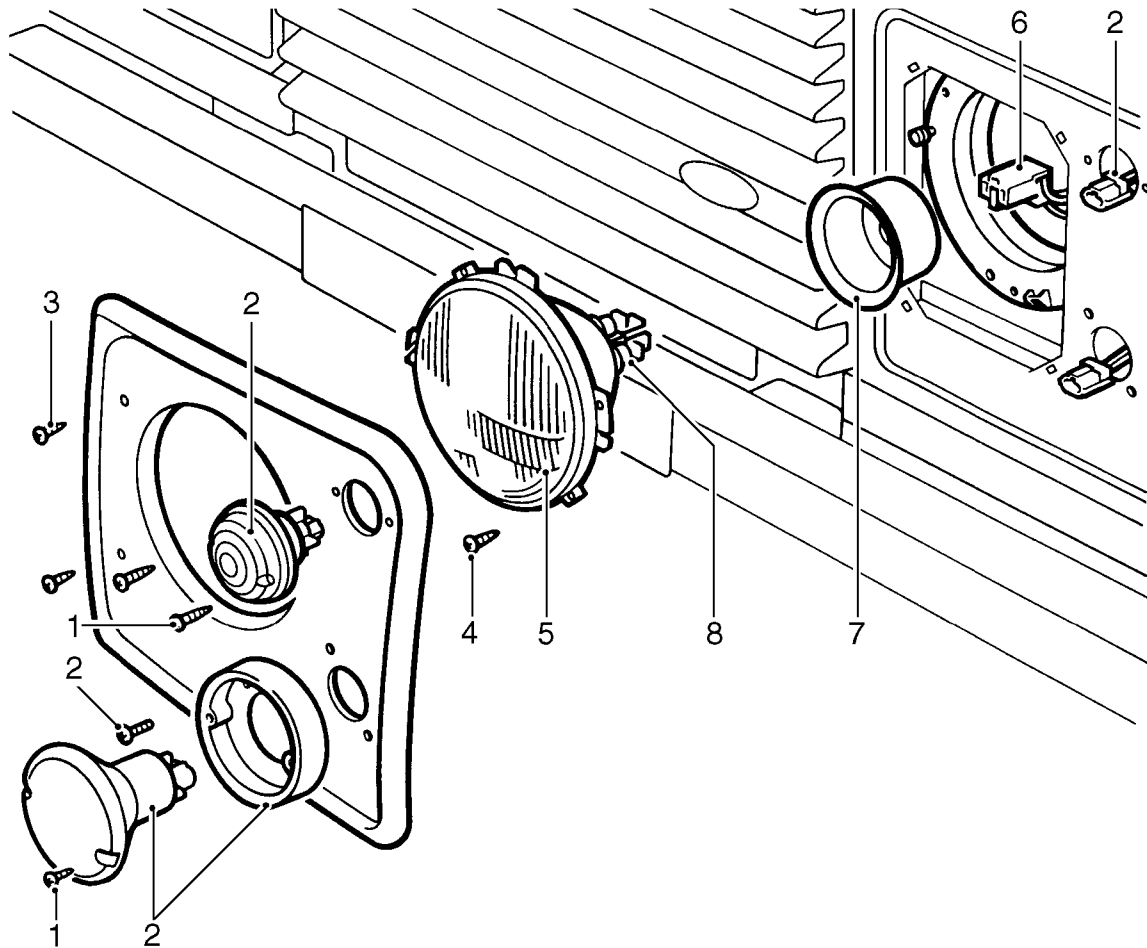

86M4239

Remove

1. Remove screws retaining side and direction indicator lamps.
2. Withdraw lamp units and disconnect plugs. Remove 2 screws and release indicator lamp boss from headlamp finisher.
3. Remove 2 screws and withdraw headlamp finisher.
4. Remove 2 headlamp retaining screws.
5. Rotate headlamp clockwise, disengage from body, and lift out headlamp.
6. Disconnect multi-plug to release headlamp.
7. Remove rubber cover.
8. Remove headlamp assembly.

Refit

9. Fit rubber cover and reconnect multi-plug.
10. Locate headlamp in body and rotate anti-clockwise to engage.
11. Fit headlamp retaining screws.
12. Fit headlamp finisher, side and direction indicator lamps.
13. Check main beam alignment. **See Headlamp beam alignment**

HEADLAMP BEAM ALIGNMENT

Service repair no - 86.40.17

Check

Check main beam alignment using beam setting equipment. Should this not be available the beam can be temporarily checked and adjusted as follows:-

1. Position vehicle, unladen, on level ground with tyres correctly inflated, approximately 4 meters from a wall or screen, marked as illustrated below.

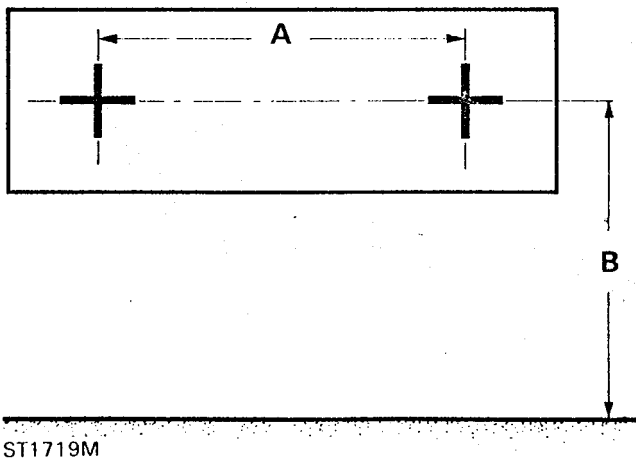

2. The beam centres 'A' are measured horizontally on the vehicle and headlamp centre dimension 'B' vertically from the ground.

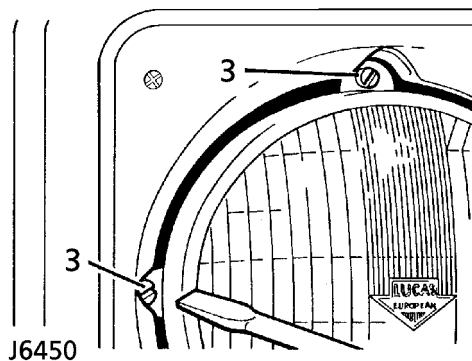

3. Switch on main beam and adjust setting, as necessary, with trimmer screws.

SIDE, TAIL AND INDICATOR LAMPS

Service repair no - 86.40.34 Parking lamp

Service repair no - 86.40.42 Indicator lamp

Service repair no - 86.40.45 Tail lamp, indicator lamp

Service repair no - 86.40.91 Reverse lamp

Remove

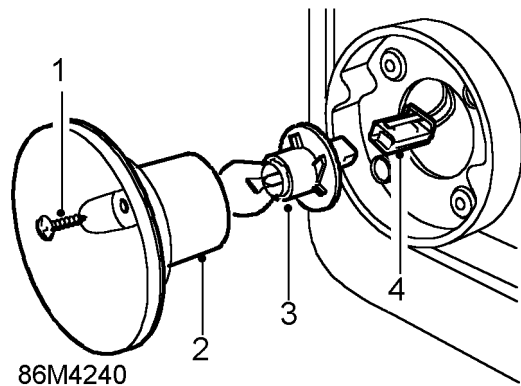
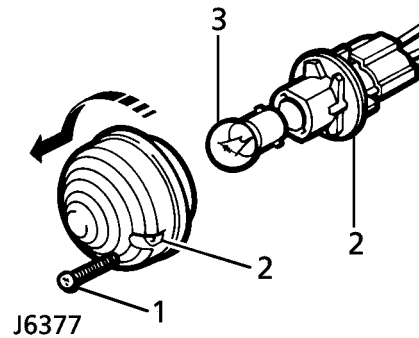

1. Release 2 screws and withdraw lens.
2. Twist counter-clockwise and withdraw bulb holder.
3. Remove bulb, bayonet fixing.
4. Disconnect bulb holder from multiplug.
5. If necessary, remove 2 screws and withdraw lamp boss.

Refit

6. Fit lamp boss, if applicable.
7. Connect bulb holder to multiplug.
8. Fit bulb of same wattage, if renewed.
9. Fit lens.



REAR NUMBER PLATE LAMP - BULB RENEWAL

Service repair no - 86.40.85

Remove

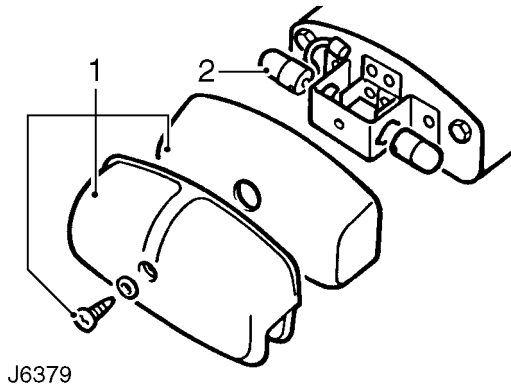

J6379

1. Remove single screw securing lamp cover and lens to bulb holder.
2. Remove bulb/s from holder.

Refit

3. Fit new bulb/s.
4. Fit lamp lens and cover.

REAR NUMBER PLATE LAMP

Service repair no - 86.40.86

Remove

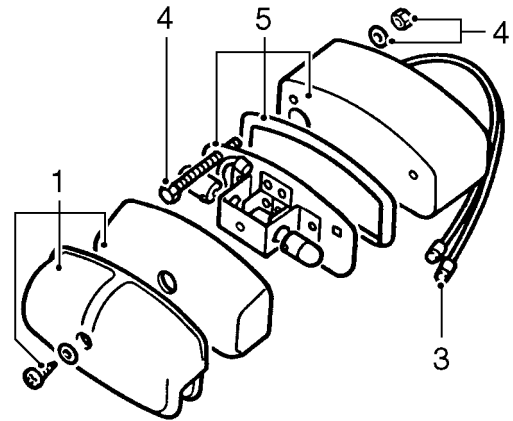

J6380

1. Remove single screw and remove lamp cover and lens.
2. Remove rear speaker. **See CHASSIS AND BODY, Repair, Radio speaker - rear**
3. Through speaker aperture, disconnect lamps leads from harness.
4. Remove 2 bolts, nuts and washers securing lamp to vehicle body.
5. Remove bulb holder, complete with rubber seal and mounting plinth.

Refit

6. Feed lamp unit leads through vehicle body and secure bulb holder, seal and plinth.
7. Fit lamp leads to harness connectors.
8. Fit radio speaker. **See CHASSIS AND BODY, Repair, Radio speaker - rear**
9. Fit lens and lamp cover.

INTERIOR LAMP - BULB REMOVAL

Service repair no - 86.45.01

Remove

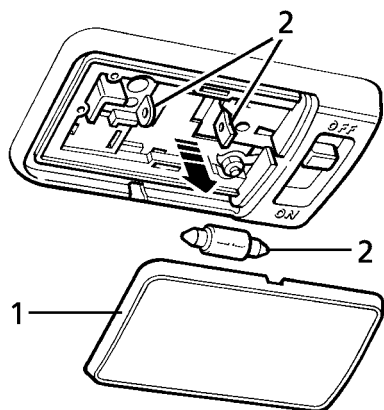

J6383

1. Prise lens from lamp unit.
2. Spread bulb holder contacts and release bulb.

Refit

3. Spread bulb holder contacts and fit new bulb.
4. Fit lamp lens.

INTERIOR LAMP

Service repair no - 86.45.02

Remove

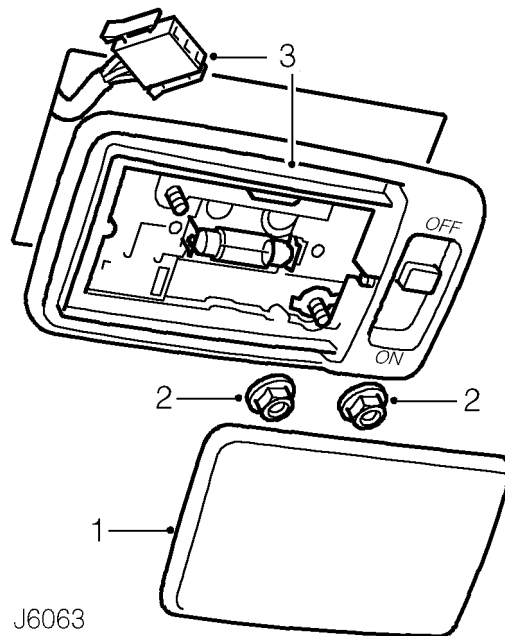

J6063

1. Prise lens cover from lamp unit.
2. Remove 2 nuts securing lamp unit to headlining and roof mounting bracket.
3. Remove lamp unit from mounting bracket studs and disconnect harness plug.
4. Remove interior lamp.

Refit

5. Reconnect harness plug and locate lamp unit on mounting bracket studs. Ensure lamp switch eyelet is correctly seated on lamp unit base.
6. Secure lamp unit to mounting bracket and fit lamp lens.



WARNING LAMP ASSEMBLY

Service repair no - 86.45.60 - Warning lamp assembly

Service repair no - 86.45.61 - Warning lamp bulb renewal

Remove

1. Disconnect battery.

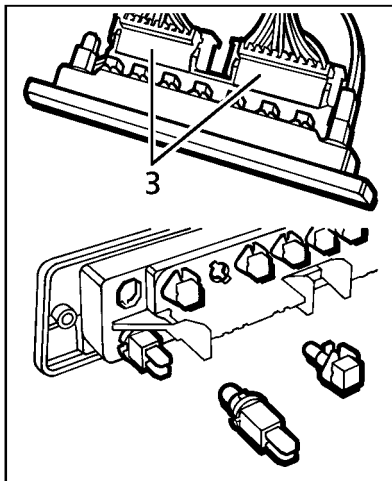
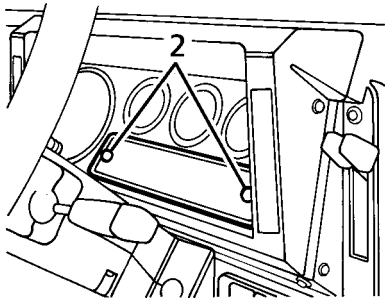

J6385

2. Remove 2 screws and withdraw warning light assembly from instrument panel.
3. Remove multi-plug to give access to warning lamp bulbs.
4. Twist bulb holder and pull it from its socket.
5. Pull bulb from holder.

Refit

6. Fit new bulb and refit holder.
7. Fit multi-plug.
8. Fit warning lamp assembly to instrument panel
9. Reconnect battery.

INSTRUMENT ILLUMINATION - BULB

Service repair no - 86.45.48

Remove

1. Remove 4 screws retaining instrument panel.
2. Release panel from fitted position to gain access to bulbs.
3. Pull bulb holder from gauge, twist bulb holder and pull from socket.
4. Pull bulb from holder.

Refit

5. Fit new bulb and refit holder.
6. Position instrument panel and secure with screws.

STARTER SWITCH

Service repair no - 86.65.03

Remove

1. Remove instrument panel. *See INSTRUMENTS, Repair, Instrument panel*
2. Remove steering column nacelle.

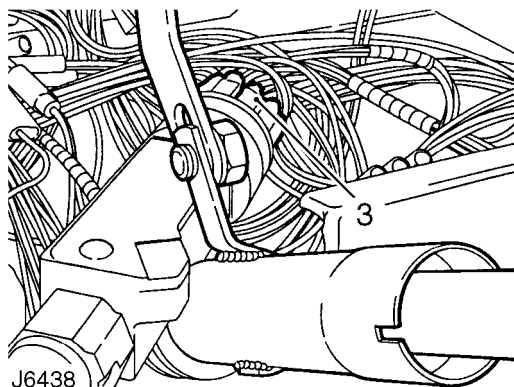

J6438

3. Note position of harness leads on back of starter switch and disconnect lugs.
4. Remove single screw and withdraw starter switch from steering column lock.

Refit

5. Fit new switch in steering column lock.
6. Connect harness leads to starter switch.
7. Fit steering column nacelle.
8. Fit instrument panel. *See INSTRUMENTS, Repair, Instrument panel; Refit*

WINDSCREEN WIPER/WASHER SWITCH

Service repair no - 84.15.34

Remove

1. Remove steering column nacelle.

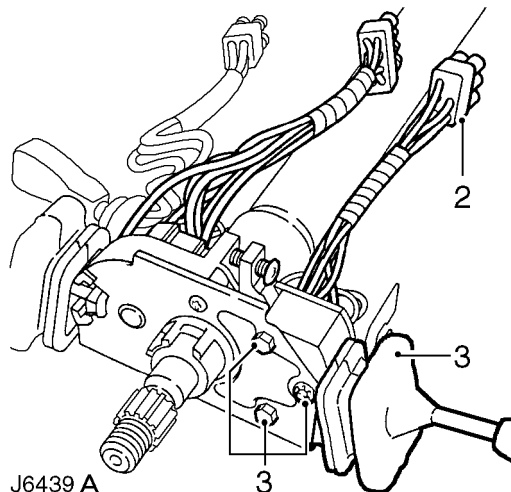

J6439 A

2. Disconnect switch multi-plug from main harness.
3. Remove 2 screws and star washer securing switch to mounting bracket.
4. Remove switch complete with harness.

Refit

5. Fit new switch to mounting bracket.
6. Reconnect switch multi-plug.
7. Fit steering column nacelle.



DIRECTION INDICATOR/HEADLAMP/HORN SWITCH

Service repair no - 86.65.55

Remove

1. Remove steering column nacelle.

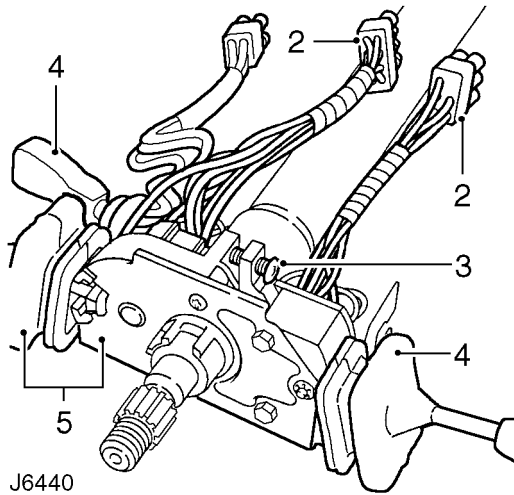

2. Disconnect 3 steering column switch multi-plugs from main harness.
3. Slacken clamp screw and withdraw switch assembly from steering column.
4. Remove fixings and detach windscreen wiper/washer and main lighting switches from mounting bracket.
5. Renew complete direction indicator/headlamp/horn switch and switch bracket assembly.

Refit

6. Fit main lighting and windscreen wiper/washer switches to mounting bracket.
7. Position switch assembly on steering column and fully tighten clamp.
8. Reconnect switch multi-plugs.
9. Fit steering column nacelle.

MAIN LIGHT SWITCH

Service repair no - 86.65.10

1. Remove steering column nacelle.

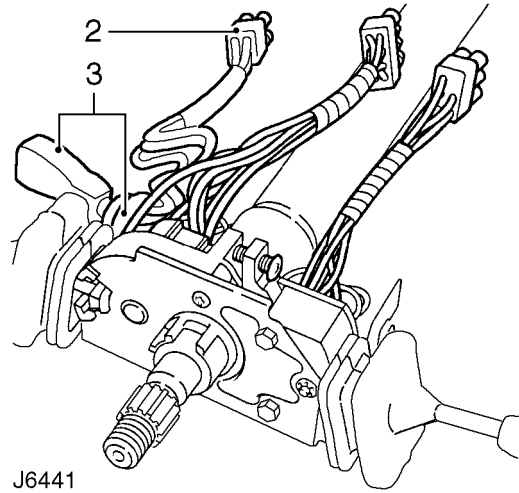

2. Disconnect main light switch multi-plug from main harness.
3. Slacken locknut and release light switch from slot in mounting bracket.

Refit

4. Fit light switch in mounting bracket.
5. Reconnect switch multi-plug.
6. Fit steering column nacelle .

SWITCH PANEL - REAR DOOR SERVICES

Service repair no - 86.65.78

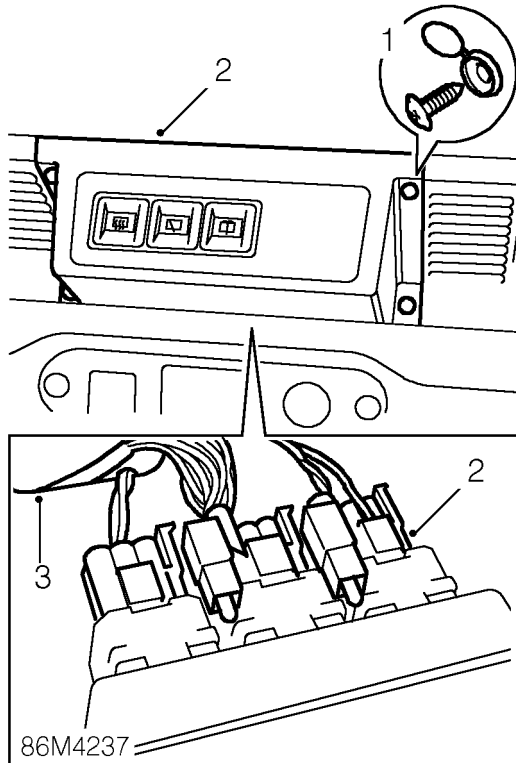
Remove

1. Release screw caps from top fixings and remove screws. Prise out 2 trim studs securing bottom of switch panel to fascia.
2. Withdraw switch panel and disconnect multi-plugs from switches and module.
3. Pull harness multi-plugs through aperture in base of panel.

Refit

4. Feed harness into switch panel and reconnect multi-plugs.
5. Position switch panel on fascia and secure with screws and trim studs.

HEATED REAR SCREEN, REAR WIPER AND WASHER SWITCHES

Service repair no - 86.65.36 - Heated rear screen

Service repair no - 84.35.33 - Rear wiper

Service repair no - 84.30.27 - Rear washer

Remove

1. Remove rear door switch panel. *See Switch panel - rear door services*

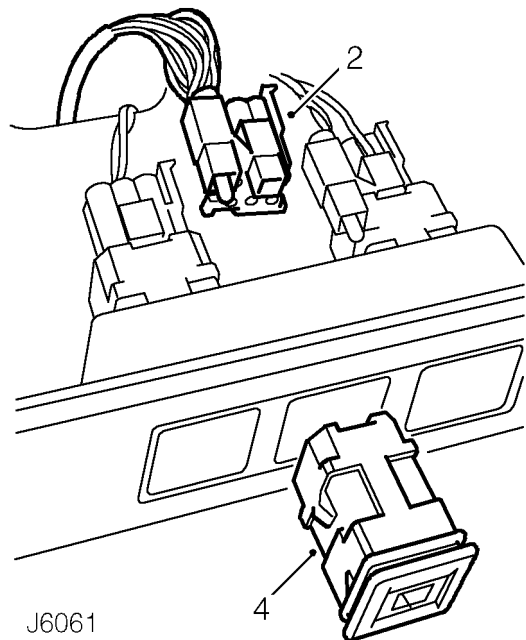

2. Disconnect multi-plug from rear of switch.
3. Press in retaining lugs and push switch through panel aperture.
4. Remove switch.

Refit

5. Fit new switch into switch panel.
6. Reconnect switch multi-plug .
7. Fit switch panel to fascia. see86rep>Switch panel - rear door services



CIGAR LIGHTER

Service repair no - 86.65.60

Remove

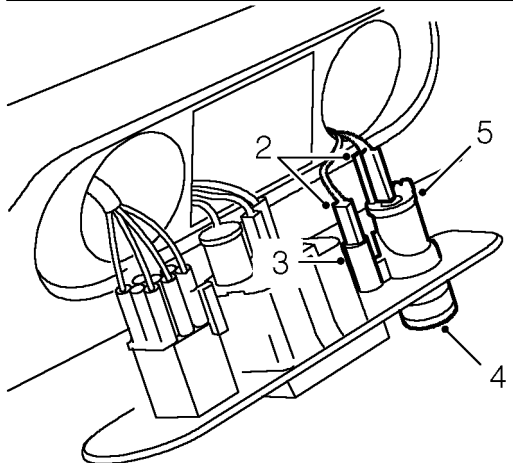
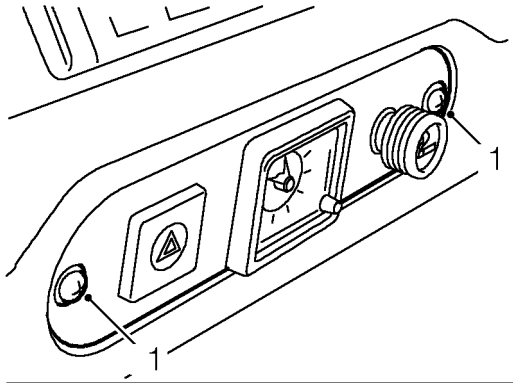

86M4236

1. Remove 2 screws and withdraw switch panel from lower fascia.
2. Disconnect electrical leads from switch housing, including illumination bulb.
3. Release 2 retaining tags and remove bulb holder from switch housing.
4. Remove cigar lighter from switch housing.
5. Press in retaining tags and withdraw housing from switch panel.

Refit

6. Fit housing to switch panel.
7. Fit bulb holder to switch housing.
8. Connect electrical leads and illumination bulb.
9. Insert cigar lighter into switch housing.
10. Fit switch panel to lower fascia.

HAZARD WARNING SWITCH

Service repair no - 86.65.50

Remove

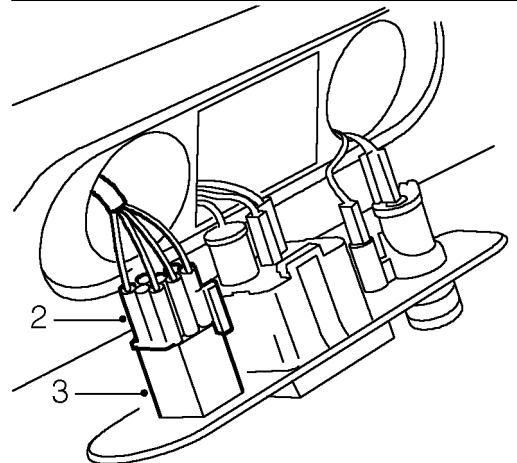
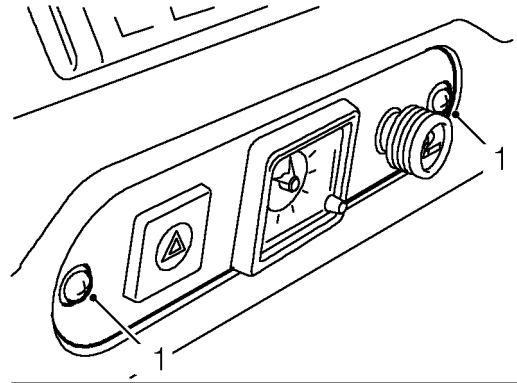

86M4238

1. Remove 2 screws and withdraw switch panel from lower fascia.
2. Disconnect multiplug from hazard warning switch.
3. Depress retainers and withdraw switch from panel.

Refit

4. Fit new switch to switch panel.
5. Connect multiplug to switch.
6. Fit switch panel.

HIGH LEVEL STOP LAMP - HARDTOP

Service repair no - 86.41.32

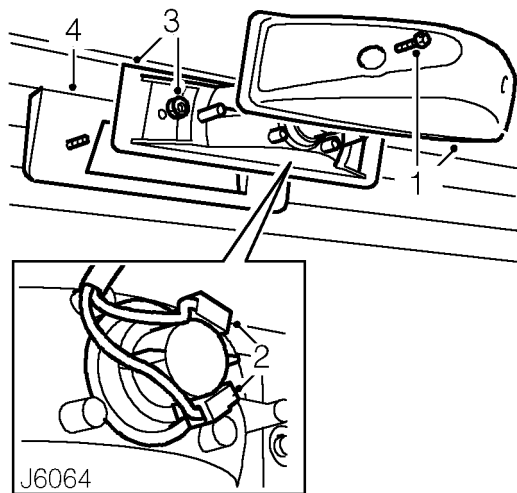
Remove

1. Remove 2 screws and remove stop lamp cover.
2. Disconnect Lucars from bulb holder.
3. Unscrew 2 nuts and remove lamp unit from fixing studs and rubber gasket.
4. Remove gasket.

Refit

5. Position gasket and stop lamp. Secure with two nuts.
6. Connect Lucars to bulb holder.
7. Position cover and secure with screws.

RADIO SPEAKER - REAR

Service repair no - 86.50.12

Remove

1. Raise rear seat cushion and fit stowage strap.

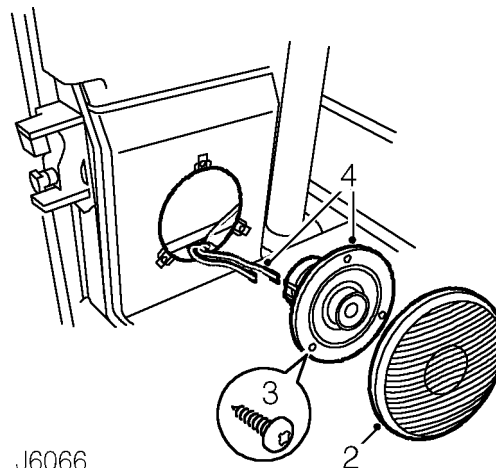

2. Carefully prise grille from speaker .
3. Remove 3 screws and withdraw speaker from trim panel.
4. Disconnect two Lucars and remove speaker.

Refit

5. Connect Lucars, position speaker and secure with screws.
6. Position grille and press firmly to secure.



GENERATOR

Service repair no - 86.10.02

Remove

1. Disconnect battery negative lead.
2. Remove drive belt. **See Auxiliary drive belt**
3. Remove cover from rear of generator.

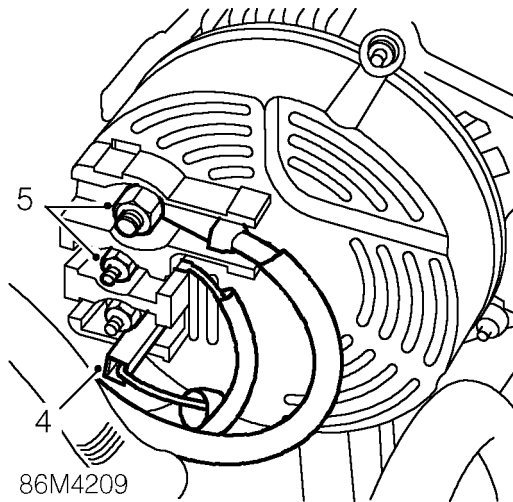

4. Disconnect Lucar from rear of generator and collect cover.
5. Remove 2 nuts securing leads to rear of generator.
6. Disconnect leads from rear of generator.

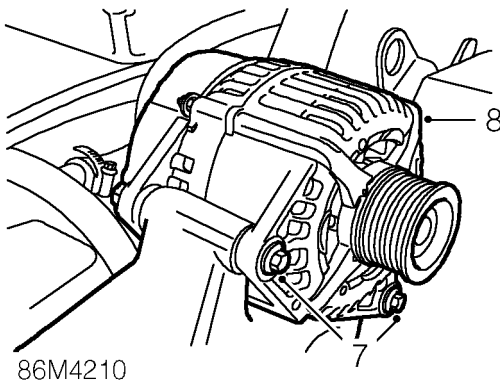

7. Remove 2 bolts securing generator to mounting bracket and collect nuts.
8. Remove generator.

Refit

9. Fit generator to mounting bracket.
10. Fit bolts and tighten nuts securing generator to mounting bracket.
11. Connect leads to rear of generator and secure with nuts.
12. Feed lucar through aperture in rear cover and connect to generator.
13. Fit cover to rear of generator.
14. Fit drive belt. **See Auxiliary drive belt**
15. Reconnect battery negative lead.

AUXILIARY DRIVE BELT

Service repair no - 86.10.03

Remove

1. Remove viscous coupling. *See COOLING SYSTEM, Repair, viscous coupling*

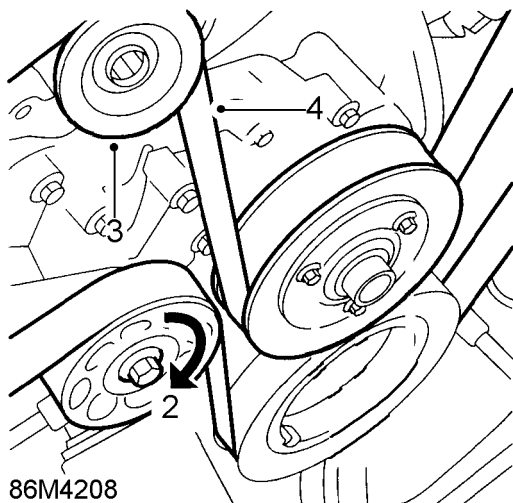

86M4208

2. Release drive belt tension by turning tensioner clockwise.
3. With tension released, remove belt from alternator pulley.
4. Remove drive belt.



NOTE: If belt is to be refitted, mark direction of rotation.

Refit

5. Clean drive belt pulley grooves and inspect for damage.
6. Fit belt to pulleys.
7. Turn drive belt tensioner clockwise and fit belt to alternator pulley.
8. Release drive belt tensioner.
9. Fit viscous coupling. *See COOLING SYSTEM, Repair, viscous coupling*

DRIVE BELT TENSIONER

Service repair no - 86.10.09

Remove

1. Remove drive belt. *See Auxiliary drive Belt*

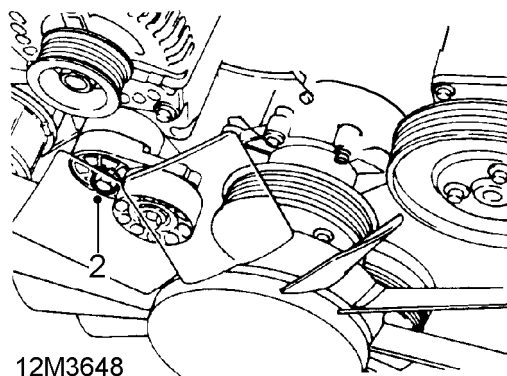

12M3648

2. Loosen tensioner centre bolt.
3. Remove bolt and tensioner.

Refit

4. Fit tensioner and bolt, tighten bolt to **50 Nm, 39 lbf ft.**
5. Fit drive belt. *See Auxiliary drive Belt*



STARTER MOTOR

Service repair no - 86.60.01

1. Position vehicle on ramp [hoist].
2. Disconnect battery negative lead.
3. Remove RH front heated oxygen sensor. **See FUEL SYSTEM, Repair, heated oxygen sensor (H02s)**
4. Remove front bolt and loosen rear bolt securing catalyst heat shield. Lower front edge of heat shield.
5. Remove bolt securing starter motor heat shield to RH engine mounting bracket.
6. Release heat shield clip from starter motor solenoid and move aside for access.
7. Lower ramp [hoist].

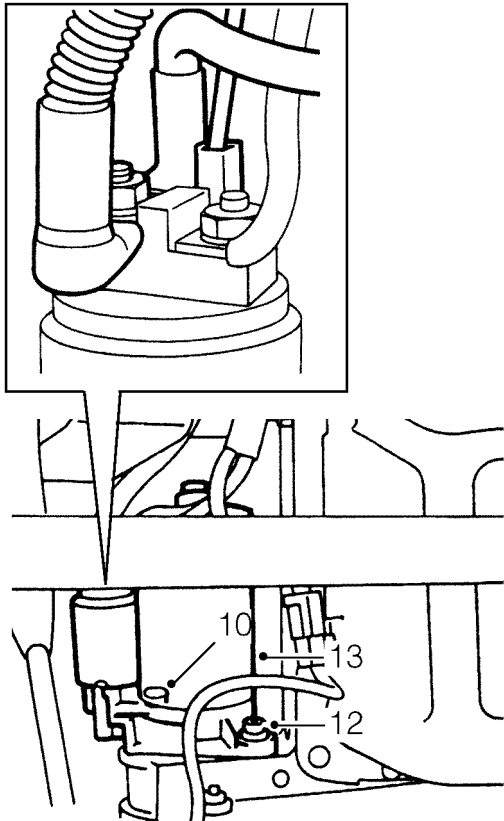

86M4213

8. Disconnect Lucar from solenoid.
9. Remove nut and disconnect feed wires from solenoid.
10. Remove top bolt securing starter motor.
11. Raise ramp [hoist].
12. Remove bottom bolt securing starter motor.
13. Remove starter motor.

Refit

14. Ensure mating faces are clean.
15. Locate starter motor and fit bottom bolt finger tight.
16. Lower ramp [hoist].
17. Fit top bolt and tighten to **42 Nm, 31 lbf ft.**
18. Connect feed wires to solenoid terminal and secure with nut.
19. Connect Lucar to solenoid.
20. Raise ramp [hoist].
21. Tighten bottom starter motor bolt to **42 Nm, 31 lbf ft.**
22. Manoeuvre heat shield into position and secure clip to solenoid.
23. Align heat shield to RH engine mounting bracket and fit retaining bolt.
24. Align catalyst heat shield and harness clip. Fit and tighten front bolt. Tighten rear bolt.
25. Fit heated oxygen sensor. **See FUEL SYSTEM, Repair, heated oxygen sensor (h02s); Refit**
26. Reconnect battery negative lead.

IMMOBILIZATION (ALARM) ECU

Service repair no - 86.77.01

Remove

1. Disconnect battery negative lead.
2. Remove steering wheel. If necessary, use puller LRT-57-014.
3. Remove instrument panel. **See INSTRUMENTS, Repair, Instrument panel**

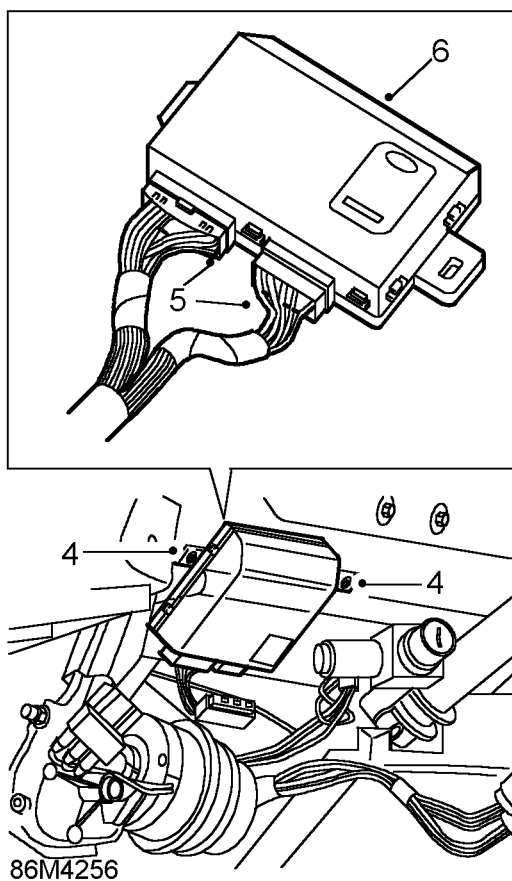

86M4256

4. Remove 2 screws securing immobilization ECU to fascia cowl.
5. Release ECU and disconnect both multi-plugs.
6. Remove ECU.



NOTE: A new ECU must be initialised using TestBook.

Refit

7. Reconnect multi-plugs and secure ECU to fascia cowl.
8. Fit instrument panel. **See INSTRUMENTS, Repair, Instrument panel**
9. Fit steering wheel.
10. Reconnect battery negative lead.



INSTRUMENT PANEL

Service repair no - 88.20.02

Remove

1. Disconnect battery negative lead.

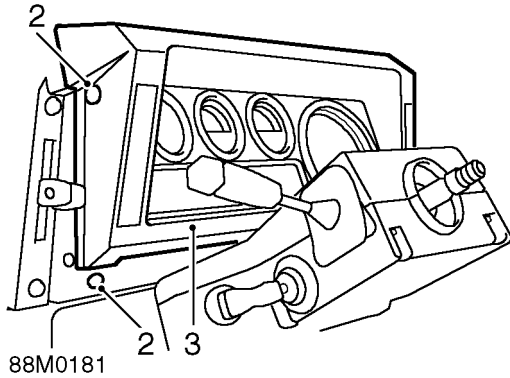

2. Remove 4 screws securing instrument panel to fascia cowl.
3. Pull instrument panel away from fascia sufficient to reach behind speedometer.
4. Disconnect instrument harness multi-plug.
5. Disconnect 2 multi-plugs from warning light connectors.
6. Withdraw panel, complete with instruments.

Refit

7. Offer up instrument panel and connect multi-plugs.
8. Secure instrument panel to fascia panel.

SPEEDOMETER

Service repair no - 88.30.01

Remove

1. Remove instrument panel assembly. **See Instrument panel**

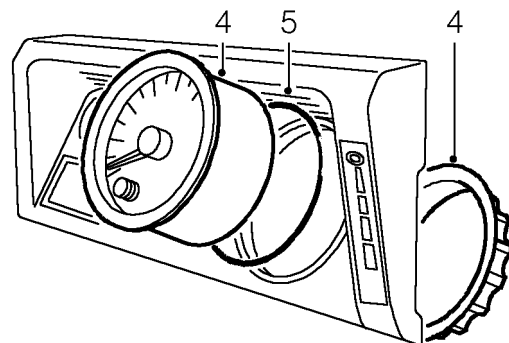
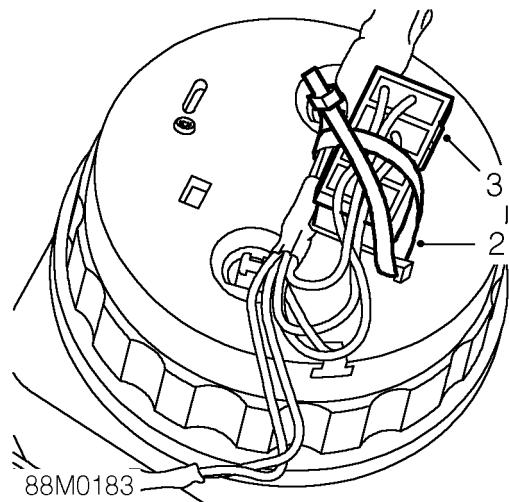

2. Release tie securing harness and multiplug to speedometer.
3. Disconnect multi-plug from speedometer.
4. Unscrew retaining ring and remove speedometer.
5. Remove 'O' ring from speedometer.

Refit

6. Fit 'O' ring to speedometer and position speedometer into instrument panel.
7. Fit retaining ring, align dial and tighten.
8. Connect multiplug to speedometer.
9. Secure harness and multiplug with tie.
10. Secure instrument panel to fascia cowl. **See Instrument panel**

TACHOMETER

Service repair no - 88.30.21

Remove

1. Remove instrument panel. *See Instrument panel*

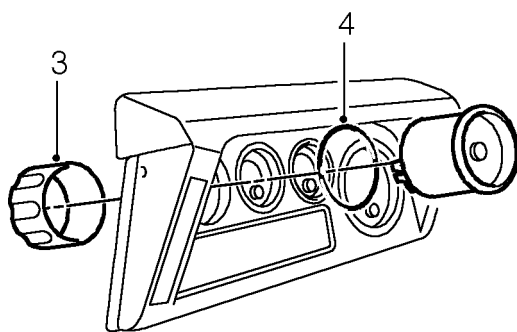
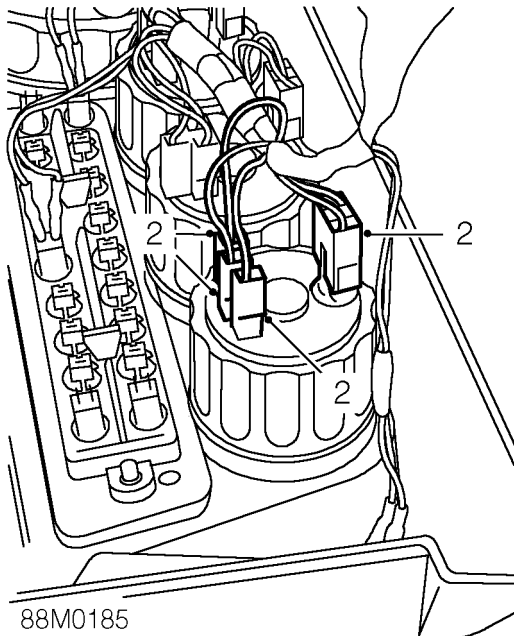

2. Release illumination bulb holder and wiring connectors from tachometer.
'-' = BLACK
'+' = WHITE
'2' = RED
3. Unscrew retaining ring and remove tachometer.
4. Remove 'O' ring from tachometer.

Refit

5. Fit 'O' ring to tachometer and position tachometer into instrument panel.
6. Fit retaining ring, align tachometer and tighten.
7. Fit instrument panel. *See Instrument panel*

FUEL AND TEMPERATURE GAUGES

Service repair no - 88.25.26 - Fuel gauge

Service repair no - 88.25.14 - Temperature gauge

Remove

1. Remove instrument panel. *See Instrument panel*

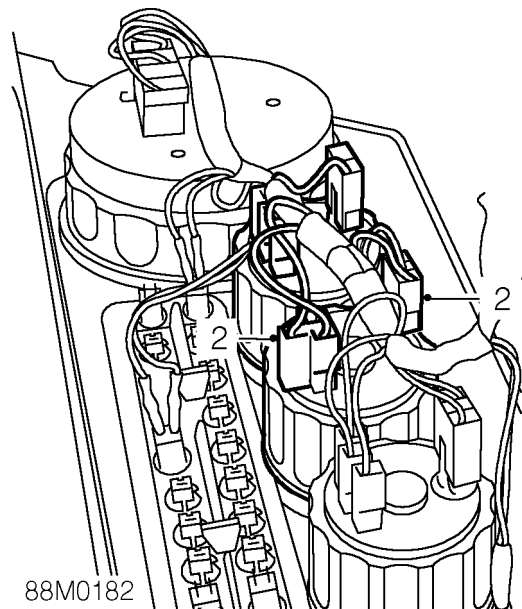

2. Release illumination bulb holder and multiplug from gauge.
3. Unscrew retaining ring and remove gauge, see 88M0186 .
4. Remove 'O' ring from gauge.

Refit

5. Fit 'O' ring to gauge and position gauge into instrument panel.
6. Fit retaining ring, align gauge and tighten.
7. Fit instrument panel. *See Instrument panel*

**CLOCK**

Service repair no - 88.15.07

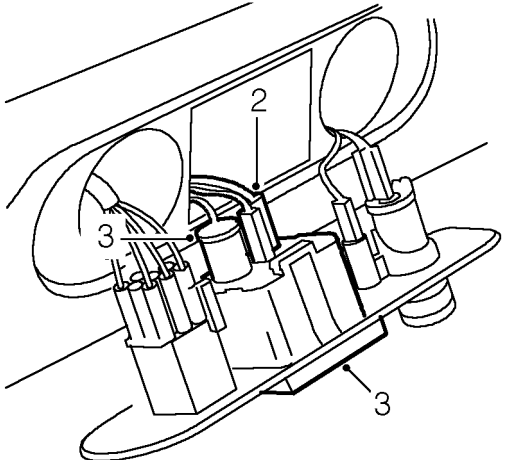
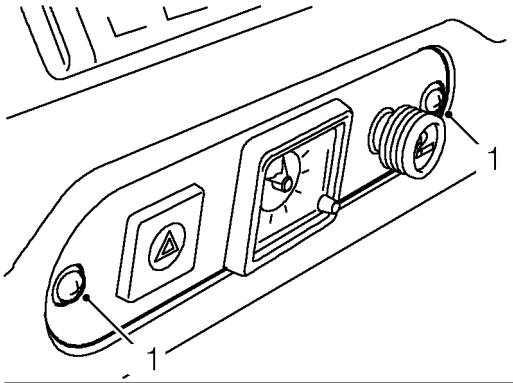
Remove

88M0180

1. Remove 2 screws and withdraw switch panel from centre dash panel.
2. Release illumination bulb holder and disconnect electrical leads from clock.
3. Press in spring retainers and remove clock from panel.

Refit

4. Fit clock into dash panel.
5. Fit electrical leads, bulb and bulb holder.
6. Secure switch panel to centre dash panel.

WARNING LIGHT PANEL

Service repair no - 88.20.18

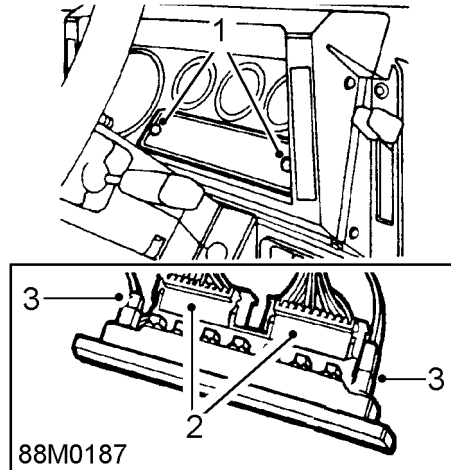
Remove

88M0187

1. Remove 2 screws and withdraw warning light panel.
2. Disconnect both multi-plugs.
3. Disconnect illumination bulb leads.
4. Remove warning light panel.

Refit

5. Fit illumination bulb leads and multi-plugs to warning light panel.
6. Secure warning light panel to instrument panel.

PRINTED CIRCUIT - WARNING LIGHT PANEL

Service repair no - 88.20.20

Remove

1. Remove warning light panel. *See Warning light panel*

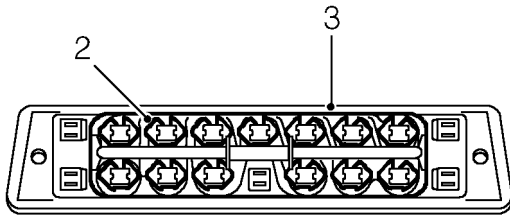

J6437

2. Remove 13 illumination bulb holders from light panel.
3. Release printed circuit from locating pins and remove from panel seatings.

Refit

4. Fit new printed circuit over panel seatings and position on locating pins.
5. Fit illumination bulbs to secure circuit.
6. Fit warning light panel. *See Warning light panel*